



Controls and Operations

Section-01-04

Komatsu has made every effort to make this manual as accurate as possible based on the information available at the time of publication and printing. Continuous improvement and advancement of product design may cause changes to machines which may not have been included in this publication. Komatsu reserves the right to make changes and improvements at any time. To ensure the most current information, please contact your service center.

Table of Contents

| | |
|--|-----------|
| Scope of This Publication, 01-04 | 7 |
| Customer Responsibilities and Warranty Advisories | 7 |
| Safety | 9 |
| Safety, Warnings, and Cautions | 9 |
| Overview of Operational Controls and Instruments | 15 |
| Left-Hand Joystick Control - Directional Control..... | 17 |
| Steer Left/Right..... | 17 |
| Cruise Speed Adjustment..... | 17 |
| Turn Signal Switches | 18 |
| Directional Control Switch | 18 |
| Acknowledge Button | 18 |
| Right-Hand Joystick Control - Hoist and Bucket Control | 19 |
| Hoist and Bucket Control Using Right Joystick | 19 |
| Joystick Control Switches and Roller | 20 |
| Hoist Detent Switch | 20 |
| Return to Dig Control Switch | 20 |
| Backdrag/Kickback Switch | 21 |
| Horn Button..... | 21 |
| Bucket Control Roller..... | 21 |
| Simultaneous Right Joystick, Switch, or Roller Command Functions | 23 |
| Cab Control Console (Operator’s Console) | 35 |
| LINCS II Touch Screen | 35 |
| Log On | 37 |
| Alarm, Warning, and Notice Screens | 39 |
| Main Operator Screen (Menu Navigation)..... | 42 |
| Bucket and Lift Arm Data..... | 43 |
| Machine Status Indicator Icons and Menu Navigation Buttons | 47 |
| Speedometer (7)..... | 50 |
| Menu Selections | 51 |
| Main Menu Sub-Selection | 51 |
| User Preferences Screen | 52 |
| Data Logging Menu | 55 |
| Channel Selection Screen | 56 |
| Logging/Monitoring | 57 |
| Event Logging Screen (Detailed)..... | 60 |
| Event Logging Screen (Summary) | 62 |
| Download Dialog..... | 62 |
| Download Procedure | 63 |

| | |
|--|------------|
| Log File Downloads | 68 |
| Production Reports | 71 |
| Machine Summary | 74 |
| Machine Summary Screen | 74 |
| Clean Screen | 75 |
| Cleaning Procedure | 76 |
| 24V Maintenance Horn | 77 |
| Park Brake Switch | 77 |
| Yellow Warning Light | 78 |
| Monitor Display Dimmer/Reset Switch | 78 |
| (#5) NOT USED | 79 |
| Key Switch/Crank Switch | 79 |
| User Access Key and Reader | 80 |
| Red Alarm Light | 80 |
| Cab Emergency Stop Switch | 80 |
| Speed Control Pedal | 81 |
| Service Brake Pedal | 82 |
| 12V Power-Ports, USB and Ethernet Terminals | 82 |
| Climate Control Switches | 83 |
| Special Key Functions | 84 |
| Overhead Keypad | 85 |
| Alternate Height Switch (1) | 85 |
| Return to Dig/Auto Level Switch (2) | 86 |
| Drive System Enable/Disable Switch (3) | 86 |
| Hazard Switch (4) | 87 |
| Throttle Switch (5) | 87 |
| Front Windshield Wiper Switch (6) | 87 |
| Rear Window Wiper Switch (7) | 88 |
| Windshield and Rear Window Washer Switches (8 & 9) | 88 |
| Not Used (10) | 88 |
| Alternate Speed Switch (11) | 88 |
| Auto Lube Switch (12) | 89 |
| Auxiliary Torque Switch (13) | 89 |
| Cruise Switch (14) | 90 |
| Beacon Light Switch (15) | 90 |
| Pole Work Lights Switch (16) | 91 |
| Cab Light Bar Lights Switch (16) | 91 |
| Rear Cowl Lights Switch (16) | 91 |
| Proximity Detection System | 93 |
| Cab Interior Lights (Dome) | 95 |
| Cab Interior Lights Manual Switch (Dome) | 95 |
| Operator's Cab | 97 |
| Operator's Seat | 101 |
| Automatic and Manual Seat Adjustments and Controls | 101 |
| Maintenance | 103 |
| Seat Belt Operation and Adjustment | 105 |
| Fastening and Unfastening the Belt | 105 |
| Fastening the Belt | 105 |
| Unfastening the Belt | 105 |
| Adjustments | 106 |
| Lengthening the Belt | 106 |
| To Shortening the Belt | 106 |
| Inspection | 106 |
| Service Switches | 107 |
| Isolation and Control Switches Assembly | 107 |
| Auto Lube Switch | 108 |
| KLENZ™ Enable Switch | 109 |

| | |
|--|------------|
| Ladder Lights Switch | 110 |
| Maintenance Lights Switch | 111 |
| Jump Start Socket | 112 |
| Starter Isolator Indication Light and Starter Isolation Switch | 112 |
| Battery Isolation Switch and Battery Isolator Indication Light | 113 |
| Central Service System (Optional) | 114 |
| Component Heater Connections (Optional) | 115 |
| Mounting and Dismounting the Machine | 117 |
| Ladder Mounted on Hydraulic Reservoir | 117 |
| Powered Access Ladder | 119 |
| "Power Step Model RL1001 & RL1002" | 119 |
| Normal Operation | 120 |
| Ground Level Ladder Operation | 120 |
| Elevated Level Ladder Operation | 121 |
| Operating the Ladder without Electrical Power | 121 |
| Service, Inspection and Lubrication | 123 |
| Powered Access Ladder Hedweld Model "C" | 125 |
| Normal Operation | 126 |
| Typical Operation at Ground or Elevated Levels | 126 |
| Operating the Ladder without Electrical Power | 127 |
| Manual Release | 128 |
| Service, Inspection and Lubrication | 128 |
| Komatsu Model | 129 |
| Typical Operation | 130 |
| Normal Operation at Ground or Elevated Levels | 130 |
| Service, Inspection and Lubrication | 130 |
| Machine Mechanical Operating Concerns | 131 |
| Computer Monitor | 131 |
| Auxiliary Steering System (Optional) | 132 |
| Diesel Engine Operational Concerns | 132 |
| Hydraulic System Monitoring and Operational Concerns | 134 |
| Grade Stability | 136 |
| Empty Bucket in Carry Position | 136 |
| Empty Bucket in Raised Position | 136 |
| Overspeed Prevention Recommendations | 137 |
| Walk-Around Inspection | 138 |
| Braking | 139 |
| Bucket Rollback Stop Blocks and Bell Crank Stop Blocks | 140 |
| Basic Machine Operating Instructions Non-Material Handling Operations | 141 |
| Pre-Starting Procedures | 142 |
| Starting the Engine | 142 |
| Starting Detroit Diesel Equipped Machines | 143 |
| Starting Cummins Engine-Equipped Machines | 143 |
| After Starting the Engine | 143 |
| Operating the Machine (Non-Material Handling Operations) | 144 |
| Test the Hoist and Bucket Functions | 144 |
| Test the Steering Function | 145 |
| Test the Dynamic Brake Function | 145 |
| Test the Service Brake Pedal | 145 |
| Changing Directions (Forward and Reverse) | 146 |
| Normal Shutdown Procedures | 146 |
| Emergency Shutdown | 147 |
| Basic Machine Operating Instructions Material Handling Operations | 149 |
| General Material Handling Operations and Precautions | 149 |
| Loader Operation | 150 |
| Safety | 150 |
| Reviewing Loader History | 150 |

| | |
|--|------------|
| Mechanical Bind Articulating | 151 |
| Mechanical Disadvantage | 151 |
| Electric Advantage..... | 152 |
| Electric Drive, Making Efficiencies..... | 152 |
| Placing Trucks | 153 |
| Becoming Efficient | 153 |
| Creating Savings | 154 |
| Improving Cycle Time | 155 |
| Controlling Traffic..... | 158 |
| Digging Theories..... | 159 |
| Managing the Dig Face | 161 |
| Controlling the Dig Face | 161 |
| Operation | 161 |
| Using the Bucket Auto Level | 162 |
| Bucket Auto Level..... | 162 |
| Digging..... | 163 |
| Hoisting and Traveling to the Truck..... | 165 |
| Dumping the Bucket | 165 |
| Lowering the Bucket and Traveling to the Dig Face..... | 165 |
| Pit Floor Maintenance..... | 166 |
| Maintaining Grade | 166 |
| Recognizing Bucket Loads | 167 |
| Responding to Bucket Overloads | 168 |
| Operator's Daily or Pre-Shift Walk-Around Inspection and Service..... | 171 |
| Safety Preparations | 171 |
| Do's and Don'ts | 187 |
| Do's..... | 187 |
| Don'ts..... | 188 |
| Vendor Literature | 189 |
| VL 15B – ANSUL Checkfire 210 Detection and Actuation System Owners Guide | 189 |
| VL 59A – AFEX Fire Suppression Systems | 189 |
| VL 97A – ANSUL Vehicle Fire Protection..... | 189 |

List of Figures

| | |
|--|-----------|
| Figure 1. Joystick operation labels | 15 |
| Figure 2. Joystick operation labels | 16 |
| Figure 3. Cab control console | 33 |
| Figure 4. User access key and reader | 37 |
| Figure 5. Countdown number on screen (alarms, warnings, notices) | 41 |
| Figure 6. Main operator screen | 42 |
| Figure 7. Clean screen | 75 |
| Figure 8. Cab control console | 76 |
| Figure 9. 24V maintenance horn | 77 |
| Figure 10. Hydraulic reservoir air release valves | 81 |
| Figure 11. 12V power-ports, USB and Ethernet connections | 82 |
| Figure 12. Climate control switches | 83 |
| Figure 13. Overhead keypad..... | 85 |
| Figure 14. Light switch operation | 91 |
| Figure 15. Front and rear light locations | 92 |
| Figure 16. Typical proximity detection system components | 93 |
| Figure 17. Cab dome light switch | 95 |
| Figure 18. Operator's cab – left side view through cab to right side | 97 |
| Figure 19. Operator's cab – right side..... | 97 |
| Figure 20. Operator's cab – left side door..... | 97 |
| Figure 21. Grab bar | 98 |
| Figure 22. Squeeze-handle to-open door | 99 |

| | |
|---|-----|
| Figure 23. Panoramic view from cab..... | 99 |
| Figure 24. Operator's seat (typical)..... | 102 |
| Figure 25. Seat belt components and fastening/unfastening procedures (typical)..... | 105 |
| Figure 26. Isolation and control switches assembly..... | 107 |
| Figure 27. Auto lube switch locations (1 of 2)..... | 108 |
| Figure 28. Auto lube switch locations (2 of 2)..... | 108 |
| Figure 29. KLENZ enable switch..... | 109 |
| Figure 30. Ladder light switches..... | 110 |
| Figure 31. Maintenance lights switch..... | 111 |
| Figure 32. Maintenance lights (maintenance work lights)..... | 111 |
| Figure 33. Jump start socket..... | 112 |
| Figure 34. Starter isolator indication light and starter isolation switch..... | 112 |
| Figure 35. Battery isolator indication light and battery isolation switch..... | 113 |
| Figure 36. Service switch locations..... | 113 |
| Figure 37. Central service system (optional)..... | 114 |
| Figure 38. Hydraulic reservoir air release valves..... | 114 |
| Figure 39. Radiator reservoir cap and manual de-pressurizing valve..... | 115 |
| Figure 40. Component heater connections..... | 115 |
| Figure 41. Ground level ladder controls..... | 120 |
| Figure 42. Elevated level ladder controls..... | 121 |
| Figure 43. Mechanical safety latch cable (ground location)..... | 122 |
| Figure 44. Back-up bleed down valve (ground location access)..... | 122 |
| Figure 45. Back-up bleed down valve cable (elevated location access)..... | 122 |
| Figure 46. Upper ladder switch..... | 126 |
| Figure 47. Powered access ladder..... | 127 |
| Figure 48. Ladder manual release..... | 128 |
| Figure 49. Powered rear access ladder switch..... | 130 |
| Figure 50. Radiator cap..... | 133 |
| Figure 51. Jump start socket..... | 133 |
| Figure 52. Allowable grade parameters..... | 136 |
| Figure 53. Typical grade/speed chart..... | 137 |
| Figure 54. Bucket rollback and bell crank stop block inspection..... | 140 |
| Figure 55. Square work line truck placement..... | 153 |
| Figure 56. Truck flow (right hand truck)..... | 158 |
| Figure 57. Truck flow (left hand truck)..... | 158 |
| Figure 58. Square dig face..... | 159 |
| Figure 59. Circular dig face..... | 159 |
| Figure 60. Do not corner dig..... | 160 |
| Figure 61. Do not operate close and sideways to the bank (or highwall)..... | 160 |
| Figure 62. Use the bucket auto level on overhead keypad (Item#2)..... | 162 |
| Figure 63. Engage the bucket straight with the bank..... | 163 |
| Figure 64. Bucket loading..... | 163 |
| Figure 65. Pit floor maintenance..... | 166 |
| Figure 66. Bucket under loaded. | 167 |
| Figure 67. Normal capacity, Green | 167 |
| Figure 68. Overload, Yellow | 167 |
| Figure 69. Critical Overload, Red | 167 |
| Figure 70. Position chart for PM procedures (typical loader)..... | 173 |
| Figure 71. Operator walk around checklist (typical loader depicted)..... | 185 |

This Page Intentionally Left Blank

Scope of This Publication, 01-04

CONTROLS AND OPERATION contains the identification and function of the controls, instruments and indicators on the instrument panel. This publication also contains basic instructions for non-material and material handling operations. It is essential that the operator(s) receive the following instructions and training before operating the machine in material handling operations.

It is essential that the operator(s) read and understand the information contained in this manual before operating the machine.

WARNING

Multiple hazards exist if the machine is not operated by a trained operator. Unexpected or unplanned machine movement can cause crush and other hazards. The machine shall only be operated by a trained operator. Failure to operator the machine with a trained operator can cause crush and other hazards resulting in serious injury or death.

The operator(s) must acquire a thorough knowledge of the function of each control and each indicator light described herein before operating the machine.

The operator(s) must also be trained in the complete operation of the machine and any special requirements of a specific job site where the machine will be operated, before operating the machine in material handling operations.

The operator(s) must read and understand any special starting, operating and maintenance instructions contained in the engine manufacturer operator's manual.

Customer Responsibilities and Warranty Advisories

P&H wheel loaders are warranted in accordance with the warranty policy provided with the machine. The recommended operating and maintenance procedures set forth shall be followed to ensure warranty coverage is not jeopardized. Failure to comply with recommended operating and maintenance procedures may void machine warranty.

Any questions or problems relating to warranty policy or administration should be directed to Komatsu Service Center. Include the model and serial number, in-service date of the machine, and hour meter reading. **We especially draw your attention to the following safety advisors.**

This Page Intentionally Left Blank

Safety

This publication contains special instructions that pertain to safety, operation, maintenance, and repair of the machine. Listed below are the signal words and symbols that precede these instructions and their meanings:

DANGER

- The danger label indicates a hazardous situation which, if not avoided, will result in death or serious injury.

WARNING

- The warning label indicates a hazardous situation which, if not avoided, could result in death or serious injury.

CAUTION

- The caution label, used with the safety alert symbol indicates a hazardous situation which, if not avoided, could result in minor or moderate injury (includes the safety alert symbol .

CAUTION

- The caution label (without safety alert symbol) is used to address practices not related to personal injury – only equipment damage.

NOTICE

The NOTICE graphic is to indicate areas of importance to the reader that are not related to personal injury or machine damage.

Safety, Warnings, and Cautions

WARNING

CRUSH HAZARD

- Crush hazards exist from unexpected machine movement if settings are changed during actual loading operation cycle. **DO NOT** set or change any settings during an actual loading operation or cycle. Before entering any information, or making/changing any settings on any screen in the LINC system, ensure the machine is in an area clear of ALL hazards and personnel. Failure to do so could result in unexpected machine movement, resulting in serious injury or death to personnel.
- Crush hazards exist from leaving the cab without setting the park brakes, which could result in unplanned and uncontrolled movement of the machine. The operator should never leave the cab with the park brake released. Set the park brake before leaving the cab. Leaving the cab without setting the park brake could cause a crush hazard from unexpected machine movement, resulting in property damage, serious injury or death.
- Crush hazards exist if the operator seat is improperly adjusted which causes loss of machine control during operation. Adjust the seat for proper access to all controls and fasten seat belt or

harness before operating the machine. Loss of machine control could cause a crush hazard resulting in serious injury or death to personnel in the operating area.

- Crush hazards exist if the operator seat belt or harness is improperly adjusted or improperly maintained. Improper adjustment or maintenance of the seat belt or harness could result in loss of machine control during operation, resulting in a crush hazard. Adjust the seat and seat belt or harness for proper access to all controls and fasten seat belt or harness before operating the machine. Always check the condition of the operator seat belts and mounting hardware before operating the machine. Failure to do so could result in serious injury. Loss of machine control could cause a crush hazard resulting in serious injury or death to personnel in the operating area.
- Crush hazards exist if attempting to transport personnel on the machine. There are no provisions on the Komatsu built wheel loader to accommodate the transportation of any persons other than the operator alone, unless a training seat in the cab is optionally provided. Ladders and catwalks attached to the machine are designed for servicing of the machine while the machine is stopped only. They are NOT designed for transporting riders at any time. Do not transport personnel or allow riders on the machine. A crush hazard is present while riding on any location of the machine other than the cab Operator's seat or training seat (if so equipped), which could result in serious injury or death.
- Crush hazards exist if the park brake is not set before operating the ladder. Before raising or lowering the ladder, set the machine park brake. Uncontrolled machine movement could cause a hazardous condition when trying to enter or exit the ladder, which could result in serious injury or death.
- Crush hazards exist. Auxiliary steering is ONLY a backup system. If something occurs in the normal steering system, auxiliary steering should only be used to steer the machine to a stopped position. It should NEVER be used in material handling operations. Loss of steering could cause a crush hazard by uncontrolled machine movement resulting in serious injury or loss of life.
- Crush hazards exist when using the Manual Bleed Valve Assembly to relieve pressure from the hoist and bucket circuits if personnel are in the area of the bucket or lift arms. Always depressurize the hydraulic hoist and bucket circuit when working on the hoist and bucket hydraulic circuit. Operating the manual bleed valve may cause the lift arms and bucket to descend rapidly. All personnel shall stand clear of the lift arms and bucket areas before the Manual Bleed Valve Assembly is used to relieve hoist and bucket circuit pressure. Before performing any procedure on any hydraulic component within the hoist and bucket circuit, the valves shall be used to relieve residual system pressure from the hoist and bucket circuits. The Hoist and Bucket Hydraulic Circuit Manual Bleed Valve Assembly shall not be operated when the engine is running. Failure to clear the bucket and lift arm areas of personnel prior to operating the valve assembly can cause a crush hazard resulting in serious injury or death.
- Crush hazards exist if exceeding the parameters shown in figure "Allowable Grade Parameters". This could result in machine rollover/tip-over. Do not exceed the parameters shown in "Allowable Grade Parameters" shown below. Machine rollover/tip-over can cause crush hazards which could result in equipment damage, serious injury or death.
- Crush hazards exist if uncontrolled machine movement occurs. Before starting the engine, ensure the machine is in a place that is safe for operations. The machine should be on a level area, and all personnel and equipment must be clear of the area. After the starting procedures and observations have been made, and it is determined the loader is safe to operate, it can be moved. Starting the machine in an area that is not safe to operate could cause a crush hazard resulting in serious injury or death.
- Crush hazards exist if uncontrolled machine movement occurs. Do not test the functionality of the hoist/bucket, steering, or brakes, unless the machine is in a place that is safe for operations. The machine should be on a level area, and all personnel and equipment must be clear of the area. After the starting procedures and observations have been made, and it is determined the loader is safe to operate, it can be moved. Crush hazard is possible from uncontrolled machine movement and could result in serious injury or death.
- Crush hazards exist if the machine is started or moves while inspections are being conducted. Place bucket flat and level on the ground. Lock out the machine's starting capability before

performing any inspection. Follow all lockout tag out rules, local rules, and local regulations to return the machine back to service. Failure to follow all lockout tag out rules, local rules, and local regulations for returning the machine back into operating condition could cause unexpected equipment component movement for personnel in the area, resulting in serious injury or death.

- Crush hazards exist from unexpected equipment component movement. When inspection and service is complete, follow all lockout tag out rules, local rules, and local regulations to return the machine back to service. Failure to follow all lockout tag out rules, local rules, and local regulations for returning the machine back into operating condition could cause unexpected equipment component movement for personnel in the area, resulting in serious injury or death.
- Crush hazards exist if operating the machine too close to the bank or high wall. Do not operate the machine parallel, and close to the bank or high wall. Material can fall, crushing personnel. Always leave enough room between the bank or high wall and the machine to move to safety should material fall from the bank or high wall or if the bank or high wall collapses. Failure to leave enough room between the machine and the bank or high wall can cause crush hazards resulting in serious injury or death.

STRUCK BY AND CRUSH HAZARDS

- Struck by or Crush hazards exist if personnel are in the travel area of the ladder when it is being lowered or raised. The ladder lowers and raises rapidly when engaged. Before lowering or raising the ladder, make sure all personnel are clear of the area. Being struck by the ladder or thrown off the machine could result in serious injury or death.
- Struck by or Crush hazards exist if personnel are in the travel area of the ladder when it is being lowered by using the back-up bleed down valve. When lowering the ladder, be certain all personnel are a safe distance from the ladder. Lowering the ladder without power by activating the "Back-up Bleed Down Valve" causes the ladder to RAPIDLY lower NON-STOP until reaching ground level. Releasing the "Back-up bleed Down Valve" knob or cable will NOT stop the ladders' rapid decent to ground level. Being struck or crushed by the ladder could result in serious injury or death.
- Struck by or Crush hazards exist if the ladder is not de-energized prior to performing maintenance work on it. Place the ladder in the "DOWN" position and use Battery Isolation Switch to de-energize the ladder prior to performing any service operations to the ladder. Failure to de-energize the ladder prior to working on it could cause personnel to be struck by or crushed by the ladder, resulting in serious injury or death.

FALL HAZARD

- Fall hazard exists due to uncontrolled ladder movement if it is not placed in the full down position before entering or exiting the ladder. Place the ladder in the full DOWN position before entering or exiting the ladder. Serious injury is possible if the ladder is not in the full DOWN and LOCKED position before entering or exiting the machine.

FALL AND CRUSH HAZARDS

- Fall hazard or Crush hazards exist if personnel rides the ladder up or down. Never ride the ladder up or down when it is being activated. Being struck by or crushed by the ladder could result in serious injury or death.
- Fall hazard or crush hazards exists when operating the ladder or using it to enter or exit the machine. To avoid personal injury and component damage it is essential that all personnel using the ladder be familiar with its operation and all indicators and alarms. Falls and crush hazards are possible if personnel are not familiar with the ladder operation before using it, which could result in serious injury.

ENTANGLEMENT HAZARDS

- Entanglement in the drive shaft or engine belts, burns if working on the engine exhaust or around hydraulic fluid or engine fluid, cuts/dismemberment if working on the radiator fan, electrical shock if working on the electrical system, skin Injection from hydraulic fluid if working on high

pressure side of hydraulic system, hearing loss from sonic sounds if working inside KLENZ system and other hazards exist. ALWAYS sound the horn for 2-3 seconds prior to starting the engine to alert personnel on the machine or in close proximity to it that the engine is about to start. Allow at least 30 seconds for them to clear the area before starting the engine. Check wing mirrors and all sides of machine from a seated position. If the horn is inoperable (see the following NOTICE), and if allowed by local rules and regulations, dismount the machine, and walk around it to be sure no one is on the machine or in close proximity to it before starting the engine. Always follow all local startup procedures before starting the machine. Failure to allow ample time for personnel to leave the area before starting the engine could cause entanglement, burns, cuts/dismemberment, electrical shock, hearing loss, skin injection, and other hazards resulting in serious injury or death.

ELECTRICAL SHOCK AND CRUSH HAZARDS

- Electrical shock and crush hazards exist if lights are serviced while the machine electrical system is energized or not locked out and unexpected machine movement occurs. Always de-energize and lock out the machine electrical system before servicing the lights. Electrical shock is possible, resulting in serious injury or death. If the machine is started up while the lights are being serviced, a crush hazard is possible from unexpected machine movement, resulting in serious injury or death.
- Electrical shock and crush hazards from uncontrolled machine movement exist if the appropriate safety procedures have not been followed and all electrical connections are not de-energized to prevent electrical shock or uncontrolled movement of the machine. Always follow all local required safety procedures and procedures in this manual before working on or starting the machine. Failure to follow procedures can cause electrical shock or uncontrolled machine movement resulting in serious injury or death.

HEARING DAMAGE OR EYE INJURY HAZARDS

- Hearing damage or eye injury hazard exists if the KLENZ™ Enable Switch is not turned to the OFF position before performing any service work to the machine. Bleed air pressure to zero psig before performing any service or repair work to the KLENZ™ system or other components powered by the compressed air system. Failure to bleed the air pressure to zero in the compressed air system can cause hearing damage or eye injury from a sonic blast within the KLENZ system resulting in serious injury.

LEAD PRESENCE HAZARD

- Battery posts, terminals and related accessories contain lead and lead components, chemicals known to the State of California to cause cancer and birth defects or other reproductive harm. Do not handle lead components without proper personal protective equipment (PPE).

SPECIAL HAZARDS

- Special hazards may exist. Before operating the equipment, it must be determined if special hazards exist in the operating area, such as toxic gasses, ground (underfoot) conditions, that require special precautions or measures to eliminate or reduce the hazard. If special hazards exist (e.g. lines: gas, electricity) in the ground: close overhead electric lines: below ground in enclosed areas: contaminated areas: other special conditions: local rules and regulations shall be followed. Serious injury or death is possible.

MULTIPLE HAZARDS

- Multiple hazards exist if the machine is not operated by a trained operator. Unexpected or unplanned machine movement can cause crush and other hazards. The machine shall only be operated by a trained operator. Failure to operate the machine with a trained operator can cause crush and other hazards resulting in serious injury or death.

INHALATION HAZARD

- Inhalation hazard exists when working around engine exhaust. Always have proper ventilation when working around engine exhaust. Failure to use proper ventilation can cause inhalation hazard resulting in serious injury or death.

WARNING: Breathing diesel engine exhaust exposes you to chemicals known to the State of California to cause cancer and birth defects or other reproductive harm.

- Always start and operate the engine in a well-ventilated area.
- If in an enclosed area, vent the exhaust to the outside.
- Do not modify or tamper with the exhaust system.
- Do not idle the engine except as necessary.

For more information go to www.P65warnings.ca.gov/diesel.

CAUTION

STRUCK BY HAZARDS

- Struck by hazard exists if the park brake is set while the machine is in motion. This will stop the machine suddenly, possibly causing the operator to be thrown unexpectedly and rapidly against the seat belt or harness. Do not use the park brakes to stop the machine unless in an EMERGENCY situation. Use the service brake to stop the machine during normal operation. Using the park brake to stop the machine can cause the operator to be thrown forward rapidly against the seat belt or harness, resulting in personal injury.
- Struck by hazard exists if using the emergency stop switch inside the cab to shut down the machine. This will immediately set the brakes and stop the machine suddenly, possibly causing the operator to be thrown unexpectedly and rapidly against the seat belt or harness. Use the emergency stop switch only in an emergency situation. Use the service brake to stop the machine during normal operation. Using the emergency stop switch to stop the machine can cause the operator to be thrown forward rapidly against the seat belt or harness, resulting in personal injury.

STRUCK-BY OR PINCH POINT HAZARDS

- Struck-by or pinch point hazards exist if the operator seat backrest upholstery is removed for cleaning or maintenance and the backrest frame is not supported. The backrest frame must be supported, for example held in place, before the backrest adjuster is operated. If this is not done, there is a danger that the backrest frame may jerk forward and cause a serious struck-by or pinching injury.

HEARING DAMAGE OR EYE INJURY HAZARDS

- Hearing damage or eye injury hazard exists if the KLENZ™ Enable Switch is not turned to the OFF position before performing any service work to the machine. Bleed air pressure to zero psig before performing any service or repair work to the KLENZ™ system or other components powered by the compressed air system. Injury from a sonic blast within the KLENZ system is possible.

BURNS AND STRUCK-BY HAZARDS

- Burns and struck-by hazards are present if pressure is not relieved before removing the hydraulic fluid reservoir filler cap. Hot oil is present and could be unexpectedly expelled from the system when opening the reservoir filler cap if the reservoir is not depressurized. Burns from hot oil is possible. Air pressure in the reservoir could cause uncontrolled movement of the cap if it is removed without depressurizing the reservoir. Always release air pressure in the hydraulic

reservoir before servicing or repairing anything requiring removal of the reservoir filler cap. Release of the reservoir air pressure is done by turning the manual air release valve to the OPEN position. The air pressure in the reservoir will be released, and at the same time, the valve will lock in the air pressure in the rest of the system. After servicing, repairing or inspecting the hydraulic oil reservoir, make certain to turn the manual air release valve (refer to “Hydraulic reservoir air release valves”) to the CLOSED position to pressurize the reservoir.

BURN HAZARD

- Burn hazard exists from hot fluids or steam when removing the radiator cap if it is not allowed to cool down before opening. Allow the engine cooling system to cool before removing the radiator cap. Do not remove radiator cap while pressure remains in the system. Hot fluids escaping can cause burns.

FALL AND SLIPPING HAZARDS

- Fall hazards and slipping hazards exist if ground conditions are not checked before dismounting the machine. Before dismounting, ensure the ground conditions are such that slipping or falling does not occur when stepping off the ladder. Always ensure firm ground before releasing the ladder. Slipping and falling could result in personal injury.

CAUTION

WELDING HAZARDS

- To prevent damage to the DDEC and Cummins electronic control system, disconnect the following BEFORE welding: battery power and ground cables and the power connector at the DDEC or Cummins Electronic Control Module (ECM). Failure to isolate the DDEC or Cummins system from high current (possible occurrence as a result of welding) can result in severe ECM damage.

WARNING

WARNING: Breathing diesel engine exhaust exposes you to chemicals known to the State of California to cause cancer and birth defects or other reproductive harm.

- Always start and operate the engine in a well-ventilated area.
- If in an enclosed area, vent the exhaust to the outside.
- Do not modify or tamper with the exhaust system.
- Do not idle the engine except as necessary.

For more information go to www.P65warnings.ca.gov/diesel.

Overview of Operational Controls and Instruments

The following provides a brief overview of the operator's controls and instruments of the Loader:

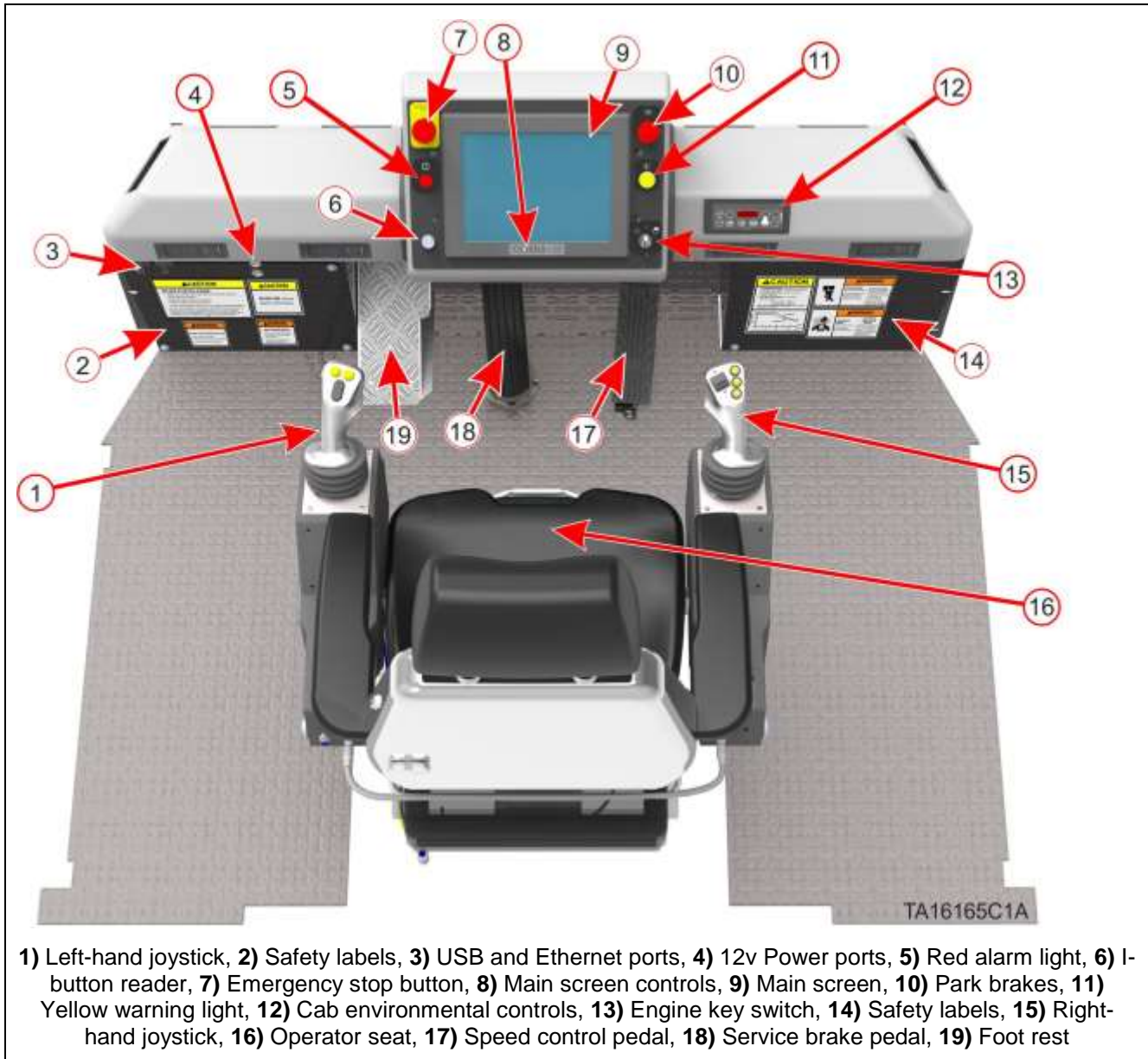

Figure 1. Joystick operation labels

The Loader is equipped with joystick controls for hoist, bucket, steering functions and cruise speed adjustment as well as others (see below). The joystick controls are mounted on support structures, attached to the operator's seat. The following pages of instructions explain the functions of each joystick as shown in "Joystick operation labels" below. The respective left/right label is located beside each joystick.

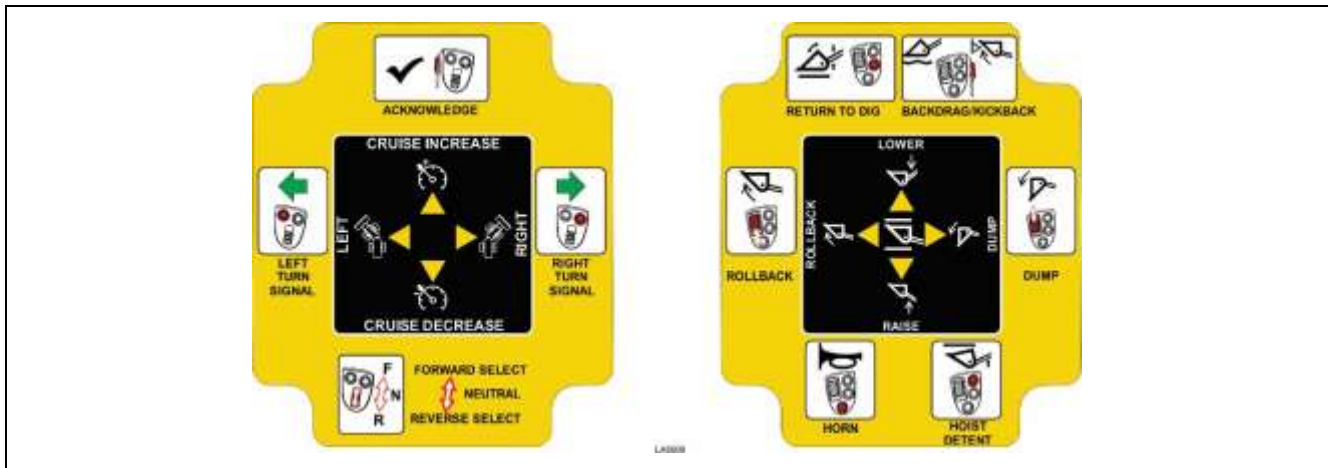

Figure 2. Joystick operation labels

Ground speed and dynamic braking are controlled by the foot-operated Speed Control Pedal. The speed control pedal is pressed to move the machine and released to actuate dynamic braking. The Service Brake Pedal is provided for holding the machine on grades or when in close proximity to a transport vehicle.

Switches for controlling various lights, accessories and other service functions of the loader are mounted on the operator's console and an overhead panel (see below for more information).

A touch screen panel provides pertinent information such as ground speed, hour meter, various gauge readings, fuel level, compressed air system pressure, etc.

The operator is alerted to a potential problem that might require the shutdown of the machine or the call for repair by warning lights, an audible alarm or text messages on the touch screen. The touch screen provides repair technicians with some operational data and fault messages in the event of a pneumatic, mechanical, electrical, or hydraulic malfunction.

The operator's cab is pressurized and has a climate control system.

NOTICE

When operating in cold climates, the oil pressure indications will be higher after starting, during engine warm-up, and when HI throttle is selected. It will take longer for the oil to warm-up and for the oil pressure to reach normal operating temperature.

CAUTION

- If the machine is to sit outside when not working with the ambient temperature below -20° C, the engine must be running at high idle with
 - With Drive system de-energized.
 - With Park Brake set.
- Or all heaters must be operational and plugged in to a power supply external to the machine if the engine is not running.
- Failure to comply with these instructions could result in serious damage to the engine or other components.

Left-Hand Joystick Control - Directional Control

(Refer to illustration “Joystick operation labels”)

- The dual-axis Directional Control Joystick has:
- Steer Left/Right
- Turn Signals
- Directional Control Switch
- Acknowledge Button
- Cruise Speed Adjustment

NOTICE

The left and right sides of the loader are determined when standing behind it or sitting in the operator’s seat. Engine left and right bank is determined by viewing the engine from the flywheel end.

Steer Left/Right

Moving the left directional joystick from side to side controls the left and right directional articulation of the machine



- Moving the directional joystick control to the left from center steers the machine to the left.
- Moving the directional joystick control to the right from center steers the machine to the right.
- The speed of steering is proportional to the distance the joystick is moved from center.
- The directional joystick control automatically returns to center when released. The machine will not automatically steer back to a straight articulation.

Cruise Speed Adjustment

After setting the cruise speed, moving the joystick forward INCREASES the cruise speed and moving the joystick backward DECREASES the cruise speed.

- The cruise button is located on the overhead keypad.
- Once activated, pressing the button again on the overhead keypad disables the cruise control.
- Actuating the service brake.



Turn Signal Switches

Two pushbutton switches to actuate the turn signal lights on the front and rear of the machine, are located on top of the left joystick. These switches have yellow covers.



Left Turn Signal



Right Turn Signal

- Pressing the left button actuates the left turn signal light on the rear of the machine, the left turn signal light on the front of the machine and the left arrow indicator on the touch screen.
- Pressing the right button actuates the right turn signal light on the rear of the machine, the right turn signal light on the front of the machine and the right arrow indicator on the touch screen.
- Pressing either button a second time will cancel the turn signal. When the machine approaches straight articulation, the turn signal will also cancel. If the machine is articulated to the right, the left turn signal cannot be activated until the degree of turn reaches close to straight. When articulated to the left, the right signal cannot be turned on until reaching near straight articulation.

Directional Control Switch

The directional control switch is a three-position maintained rocker-type switch mounted on the steering joystick control. It is used to select forward neutral, or reverse direction of machine movement.



- Moving the switch to the front position selects FORWARD machine movement.
- Moving the switch to the back position selects REVERSE machine movement.
- Moving the switch to the center position selects NEUTRAL machine movement.

When the directional switch is moved to the reverse position, the backup alarm will sound and the backup lights will come on. They will remain on until the switch is moved to the neutral or forward position.

The machine's direction, FORWARD or REVERSE, can be selected without releasing the speed control pedal. Once the directional control switch is moved to the opposite direction, the machine's control system automatically applies dynamic braking, slows the machine to a complete stop, and then changes the machine's direction. While this change of direction is being processed by the control system, the speed control pedal can remain fully depressed. This will ensure that cycle times are maximized.

The center position is the neutral position. The directional switch must be in the center position to start the engine. When the switch is in the center position, the loader will not be powered in either direction if the speed control pedal is pressed.

Acknowledge Button

- The Acknowledge button is located on the side of the directional control (left) joystick. Pressing the button acknowledges the WARNING, ALERT or NOTICE screens on the touch screen.
- Pressing and holding the acknowledge button for two (2) seconds will bypass the engine shutdown timer.



Acknowledge

Right-Hand Joystick Control - Hoist and Bucket Control

(Refer to illustration “Joystick operation labels”)

The dual-axis Hoist/Bucket control joystick has the following command functions:

- Forward and backward positions for raising and lowering the lift arms

Lowering the lift arms also controlled by using buttons

Hoist Detent

Return to Dig

- Side-to-side (left or right) positions for bucket rollback and dumping.

Also controlled by **Bucket Control Roller Potentiometer** on top of the joystick.

- **Return to Dig Switch:** Lowers the lift arms to a preset distance from the ground and positions the bucket to a preset position.
- **Backdrag/Kickback Switch:** Below a certain lift arm angle, drop the bucket to the ground by placing the hoist lower function in a float mode. Above a certain height, the button rolls the bucket back to a level position.
- **Hoist Detent Switch:** raises the lift arms to full height or alternative height if “alt height” is active.
- **Horn Switch:** actuates the horn solenoid while held.

Hoist and Bucket Control Using Right Joystick

Speed of lift arm and bucket movement is proportional to the distance the joystick is moved from neutral (center). The further the joystick is moved from center the faster the lift arms or bucket move in the commanded direction.

- Moving the hoist control joystick backward from neutral (center) causes the lift arms to RISE (power up).
- Moving the hoist control joystick forward from neutral (center) causes the lift arms to LOWER (power down).

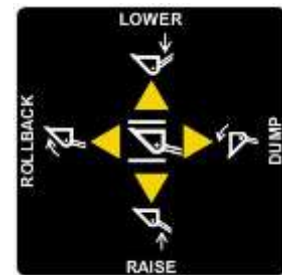

L.A6500A

The center position is the neutral position. Moving the hoist control joystick toward the center position, from either position (forward or backward), causes the lift arms motion to slow. When the joystick reaches center, the lift arm motion will stop. The hoist/bucket control joystick automatically returns to center when released.

- Moving the joystick to the left moves the bucket toward rollback position (until the joystick is released).
- The rollback position is used to load the bucket and to transport the load.
- Moving the joystick to the right causes the bucket to dump.
- Moving the joystick to a quadrant between those described above causes both actions to occur simultaneously (bucket function takes priority). See “Simultaneous Right Joystick, Switch, or Roller Command Functions” for examples.

Joystick Control Switches and Roller

Hoist and bucket movements can also be controlled by using the three pushbutton switches or the roller switch on the joystick control.

NOTICE

Joystick commands override pushbutton switch commands.

Bucket Control Roller overrides bucket commands via joystick movement.

Hoist Detent Switch

The hoist detent switch is a pushbutton switch that causes the lift arms to rise to the height determined by the bucket height switch or to full height if the bucket height switch is in the OFF position. The lift arms rise at full speed.



Return to Dig Control Switch

The Return to Dig control switch is a pushbutton switch. Pressing this switch with auto leveling enabled, causes the bucket to descend or rise to the set position. The bucket will not free fall under this condition but will descend as rapidly as fluid being expelled from the lift cylinders will allow.

The Return to Dig command is cancelled if a power down or hoist up command is given by the joystick



Backdrag/Kickback Switch

Backdrag Switch:

If the bucket is close to the ground and the Backdrag switch is pressed, the lift arms will transition from a hydraulically held position to a sequence of “power down” then float position. The float position hydraulically connects the hoist cylinder base and rod ports together. This allows the bucket to rest on the ground with the bucket floating across the pit floor. The bucket can still be operated as normal in either a held position, dumped forward (teeth down), or be rolled back (loading). This float function allows for pit floor cleanup or the ability to cut grades or follow material seams.



The Backdrag command is cancelled if a power down or hoist up command is given by the joystick.

Kickback Switch:

When the bucket is higher than the normal loading range (higher than about 6 feet) the kickback function will function when the switch is pressed. Above this level, this switch, when depressed will roll the bucket back (only if the bucket is in a dumped / teeth down position) until the floor of the bucket is parallel to the ground. This allows the operator to roll the bucket back to a level position with the press of a button. Typically this function is used when dumping into a truck that has taller side boards than the maximum dumped bucket lift height of the loader. By “kicking back” the bucket lip to parallel to the ground, contact to the side of a truck body should be avoided while reversing the machine.

Horn Button

The air horn sounds until the button is released or air pressure drops to a level that will no longer cause the horn to actually make sound. The horn is actuated by a solenoid mounted on top of the cab, close to the actual horn.



Bucket Control Roller

The spring-centered roller controls bucket rollback and dump movements. Rolling the roller back from center rotates the mouth of the bucket upward (roll back). Rolling the roller forward from center rotates the mouth of the bucket downward (dump). Bucket rollback and dump movement speed is proportional to how far the roller is rolled forward or backward from neutral (center). Releasing the roller causes it to return to the neutral (center) position. Bucket movement will stop and hold at the position where the roller is released.



Rollback



Dump

To move the bucket in the opposite direction, the roller must be rolled either forward or backward, as required. If the Return to Dig button is pressed, the bucket will automatically return to the pre-set location (if the auto level switch is ON – LED is illuminated).

The Bucket Control Roller controls the speed and direction of bucket movement. Once initiated, the bucket motion will continue until reaching full position, until the roller is released or until another command is initiated by the roller (past center into opposite direction). Greater (distance) roller movement affects the speed of the bucket dump or rollback, not the distance it travels (unless the roller is released).





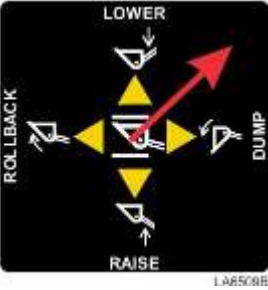
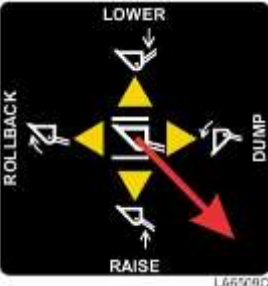
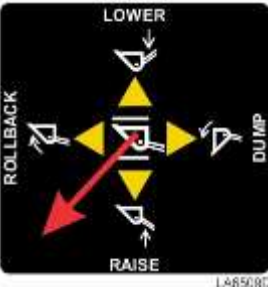
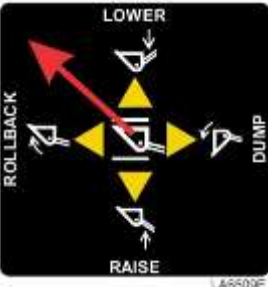

The Bucket Control Roller controls movement of the bucket in both directions and over-rides an opposing joystick command. See “Simultaneous Right Joystick, Switch, or Roller Command Functions” below for examples.



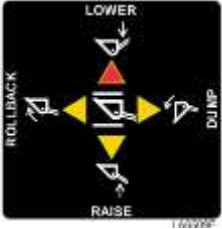



The following RIGHT JOYSTICK commands will continue until the joystick is moved to another position or until the final lift arm or bucket position is reached.







| Right Joystick Location | Causes this movement |
|---|--|
|  | <ul style="list-style-type: none"> The lift arms lower and the bucket moves toward dump position. |
|  | <ul style="list-style-type: none"> The lift arms rise slowly and the bucket moves toward dump position. |
|  | <ul style="list-style-type: none"> The lift arms rise slowly and the bucket moves toward rollback position. |
|  | <ul style="list-style-type: none"> The lift arms lower and the bucket moves toward rollback position. |







Simultaneous Right Joystick, Switch, or Roller Command Functions

The following examples describe what movement occurs when the joystick is used to command various lift arm or bucket movements, then a joystick switch is pressed.

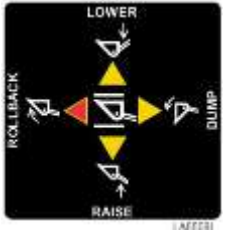
| | |
|---|--|
|  | <p>Joystick Power Down (lower) is actuated and held:</p> <p>While these conditions exist:</p> <ul style="list-style-type: none"> ● The lift arms are slightly above “centerline-level”. ● Bucket Auto Level is ON. Bucket is level ● Joystick Power Down is commanded (Joystick moved forward). <ul style="list-style-type: none"> ○ Lift arms begin movement downward toward ground elevation. |
| <p>Then a command switch is pressed</p> | |
| <p>Switch Pressed</p> | <p>This movement occurs</p> |
|  | <ul style="list-style-type: none"> ● Power Down continues as lift arms lower |
| <p>Backdrag/Kickback</p> | |
|  | <ul style="list-style-type: none"> ● Hoist Detent command has no effect. ● Lift arms continue to lower. |
| <p>Hoist Detent</p> | |
|  | <ul style="list-style-type: none"> ● Return to Dig command has no effect ● Power Down continues as lift arms lower <ul style="list-style-type: none"> ○ Lift arms lower when the joystick is held in Power Down command position. |
| <p>Return to Dig</p> | |
| <p>Or the roller is actuated</p> | <p>This movement occurs</p> |
|  | <ul style="list-style-type: none"> ● Lift arms travel downward ● Bucket lip travels downward toward Dump position <ul style="list-style-type: none"> ○ As long as the roller is held (command is demanded by potentiometer). ○ Until full bucket dump position is reached. |
| <p>Dump</p> | |
|  | <ul style="list-style-type: none"> ● Lift arms travel downward ● Bucket travels upward toward Rollback position <ul style="list-style-type: none"> ○ As long as roller is held (command is demanded by potentiometer). ○ Until full roll back position is reached. |
| <p>Rollback</p> | |





| | |
|---|--|
|  | <p style="text-align: center;">Joystick Power Up (raise) is actuated and held:</p> <p>While these conditions exist:</p> <ul style="list-style-type: none"> ● The lift arms are at “ground level” ● Bucket Auto Level is ON. Bucket is level ● Joystick Power Up is commanded (Joystick moved fully backward) <ul style="list-style-type: none"> ○ Lift arms begin movement upward toward fully raised position. |
| <p>Then a command switch is pressed</p> | |
| <p style="text-align: center;">Switch Pressed</p> | <p style="text-align: center;">This movement occurs</p> |
|  <p style="text-align: center;">Backdrag/Kickback</p> | <ul style="list-style-type: none"> ● Power up continues and lift arms rise |
|  <p style="text-align: center;">Hoist Detent</p> | <ul style="list-style-type: none"> ● Power up continues and lift arms rise |
|  <p style="text-align: center;">Return to Dig</p> | <ul style="list-style-type: none"> ● Power up continues and lift arms rise |
| <p style="text-align: center;">Or the roller is actuated</p> | <p style="text-align: center;">This movement occurs</p> |
|  <p style="text-align: center;">Dump</p> | <ul style="list-style-type: none"> ● Power up continues and lift arms rise ● Bucket travels to Dump position as lift arms rise <ul style="list-style-type: none"> ○ As long as roller is held (command is demanded by roller). ○ Until full position is reached |
|  <p style="text-align: center;">Rollback</p> | <ul style="list-style-type: none"> ● Power up continues and lift arms rise ● Bucket travels to Rollback position as lift arms rise <ul style="list-style-type: none"> ○ As long as roller is held (command is demanded by potentiometer). ○ Until full position is reached |

| | |
|---|---|
|  | <p style="text-align: center;">Joystick Dump is actuated and held:</p> <p>While these conditions exist:</p> <ul style="list-style-type: none"> ● The lift arms are slightly above “centerline-level” ● Bucket Auto Level is ON. Bucket is level ● Joystick Dump is commanded (Joystick moved fully right) ● Bucket begins moving lip downward toward dump position. |
| Then a command switch is pressed | |
| Switch Pressed | This movement occurs |
|  <p>Backdrag/Kickback</p> | <ul style="list-style-type: none"> ● Bucket Dump continues. |
|  <p>Hoist Detent</p> | <ul style="list-style-type: none"> ● Bucket Dump continues. ● Lift arms begin to rise at a reduced rate of speed. |
|  <p>Return to Dig</p> | <ul style="list-style-type: none"> ● Bucket Dump continues. |
| Or the roller is actuated | This movement occurs |
|  <p>Dump</p> | <p>Roller is moved forward toward dump position.</p> <ul style="list-style-type: none"> ● Bucket Dump continues. <ul style="list-style-type: none"> ○ Distance of Potentiometer movement controls speed of bucket movement. |
|  <p>Rollback</p> | <p>Roller is moved forward toward rollback position.</p> <ul style="list-style-type: none"> ● Bucket Dump stops. ● Bucket roll back begins. <ul style="list-style-type: none"> ○ Distance of Potentiometer movement controls speed of bucket movement. |

| | |
|---|---|
|  | <p style="text-align: center;">Joystick Rollback is actuated and held:</p> <p>While these conditions exist:</p> <ul style="list-style-type: none"> ● The lift arms are above “ground level” ● Bucket Auto Level is ON. Bucket is level ● Joystick Rollback is commanded (Joystick moved fully left) ● Bucket lip begins movement upward toward rollback position. |
| Then a command switch is pressed | |
| Switch Pressed | This movement occurs |
|  <p style="text-align: center;">Backdrag/Kickback</p> | <ul style="list-style-type: none"> ● Bucket Rollback continues. |
|  <p style="text-align: center;">Hoist Detent</p> | <ul style="list-style-type: none"> ● Bucket Rollback continues. |
|  <p style="text-align: center;">Return to Dig</p> | <ul style="list-style-type: none"> ● Bucket Rollback continues. |
| Or the roller is actuated | This movement occurs |
|  <p style="text-align: center;">Dump</p> | <ul style="list-style-type: none"> ● Bucket rollback stops ● Bucket Dump begins. |
|  <p style="text-align: center;">Rollback</p> | <ul style="list-style-type: none"> ● Bucket Rollback continues. |

There is no operational value for simultaneously depressing any combination of Backdrag/Kickback, Hoist Detent or “Return to Dig” buttons. Those combinations are not discussed herein.

The following examples describe what movement occurs when a joystick switch is pressed to demand various lift arm or bucket movements, then the joystick is used to command lift arm or bucket movement.

| | |
|---|---|
|  | <p style="text-align: center;">Backdrag Function</p> <p style="text-align: center;">Backdrag/Kickback Switch is pressed:</p> <p>While these conditions exist:</p> <ul style="list-style-type: none"> ● The lift arms are slightly above “ground level” ● Bucket Auto Level is ON. Bucket is level ● The Backdrag/Kickback is commanded (Button selected) ● Lift arms begin movement downward |
| <p style="font-size: 24px; margin: 0;">NOTICE</p> | |
| <p>The lift arms stop moving and hold at the current position.</p> | |
| <p>Then a command is initiated by right joystick movement</p> | |
| <p>100% Command</p> | <p>This movement occurs</p> |
|  | <ul style="list-style-type: none"> ● Backdrag/Kickback command is cancelled. ● Lift arms move downward when the joystick is held in Lower command position. ● Bucket remains in last position before Backdrag/Kickback was cancelled. |
| <p>Lower</p> | |
|  | <ul style="list-style-type: none"> ● Backdrag/Kickback command is cancelled. ● Lift arms move upward when the joystick is held in Raise command position. ● Bucket remains in last position before Backdrag/Kickback was cancelled. |
| <p>Raise</p> | |
|  | <ul style="list-style-type: none"> ● Lift arms stop downward movement ● Bucket lip moves downward toward dump position. |
| <p>Dump</p> | |
|  | <ul style="list-style-type: none"> ● Lift arms stop downward movement ● Bucket lip moves upward toward rollback position when the joystick is held in rollback command position. |
| <p>Rollback</p> | |



Kickback

**Kickback Function
Backdrag/Kickback Switch is pressed:**

While these conditions exist:





- The lift arms are above approximately 6 feet elevation.
- Bucket Auto Level is ON.
Bucket is level
- The Backdrag/Kickback is commanded (Button selected)



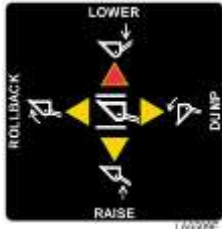
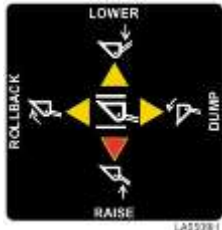
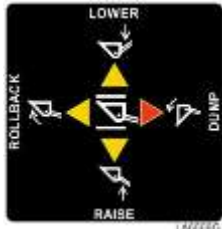
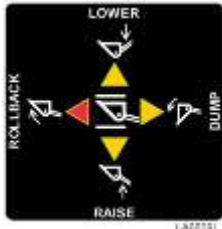

NOTICE

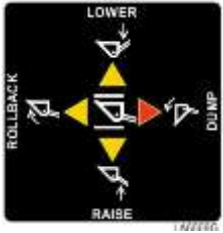

The lift arms stop moving and hold at the current position.



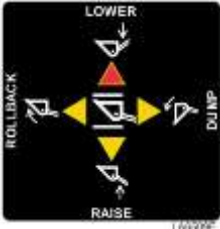
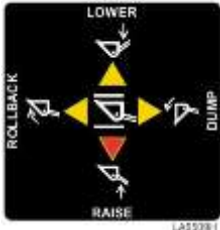
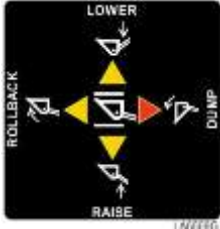

Then a command is initiated by right joystick movement

| 100% command | This movement occurs |
|--|---|
|  <p>Lower</p> | <ul style="list-style-type: none"> ● Lift arms move downward when the joystick is held in Lower command position. ● Bucket remains in last position before Backdrag/Kickback was cancelled. |
|  <p>Raise</p> | <ul style="list-style-type: none"> ● Lift arms move upward when the joystick is held in Raise command position. ● Bucket remains in last position before Backdrag/Kickback was cancelled. |
|  <p>Dump</p> | <ul style="list-style-type: none"> ● Backdrag/Kickback command is cancelled. ● Lift arms stop downward movement ● Bucket lip moves downward toward dump position. |
|  <p>Rollback</p> | <ul style="list-style-type: none"> ● Backdrag/Kickback command is cancelled. ● Lift arms stop downward movement ● Bucket lip moves upward toward rollback position when the joystick is held in rollback command position. |

| | |
|--|--|
|  | <p style="text-align: center;">Hoist Detent Switch is pressed:</p> <p>While these conditions exist:</p> <ul style="list-style-type: none"> ● The lift arms are slightly above ground elevation ● Bucket Auto Level is ON. Bucket is level ● The Hoist Detent is commanded (Button selected) ● Lift arms begin movement upward. |
| <p>Then a command is initiated by right joystick movement</p> | |
| <p>100% Command</p> | <p>This movement occurs</p> |
|  <p style="text-align: center;">Lower</p> | <ul style="list-style-type: none"> ● Detent command is cancelled. ● Lift arms stop movement upward and immediately begin moving down. |
|  <p style="text-align: center;">Raise</p> | <ul style="list-style-type: none"> ● Detent command is cancelled. ● Lift arms rise when the joystick is held in “raise” command position. |
|  <p style="text-align: center;">Dump</p> | <ul style="list-style-type: none"> ● Lift arms rise at a reduced rate of speed. ● Bucket lip moves downward toward dump position when the joystick is held in dump command position. |
|  <p style="text-align: center;">Rollback</p> | <ul style="list-style-type: none"> ● Lift arms rise at a reduced rate of speed. ● Bucket lip moves upward toward rollback position when the the joystick is held in rollback command position. |

| | |
|---|---|
|  <p>Return to Dig</p> | <p>Return to Dig Switch is pressed:</p> <p>While these conditions exist:</p> <ul style="list-style-type: none"> ● The lift arms are not at “return to dig” set point. ● Bucket Auto Level is ON. Bucket is level ● The Return to Dig is commanded (Button selected) ● Lift arms begin movement. |
| <p>Then a command is initiated by right joystick movement</p> | |
| <p>100% Command</p> | <p>This movement occurs</p> |
|  <p>Lower</p> | <ul style="list-style-type: none"> ● Return to Dig command is cancelled. ● Lift arms move downward when the joystick is held in Lower command position. ● Bucket remains in last position before Backdrag/Kickback was cancelled. |
|  <p>Raise</p> | <ul style="list-style-type: none"> ● Return to Dig command is cancelled. ● Lift arms move upward when the joystick is held in Raise command position. ● Bucket remains in last position before Backdrag/Kickback was cancelled. |
|  <p>Dump</p> | <ul style="list-style-type: none"> ● Return to Dig command is cancelled. ● Lift arms stop movement. ● Bucket moves toward dump position. |
|  <p>Rollback</p> | <ul style="list-style-type: none"> ● Return to Dig command is cancelled. ● Lift arms stop movement. ● Bucket moves toward rollback position. |

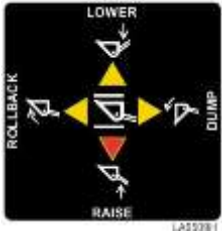
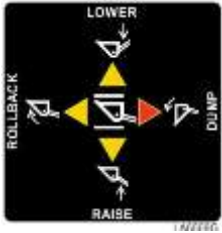
| | |
|--|---|
|  <p>Dump</p> | <p>Dump is actuated and held:</p> <p>While these conditions exist:</p> <ul style="list-style-type: none"> ● The lift arms are above “ground level” ● Bucket Auto Level is ON. Bucket is level ● The Dump is commanded (Roller moved forward and held) ● Bucket lip begins movement downward |
| <p>Then a command is initiated by right joystick movement</p> | |
| <p>100% Command</p> | <p>This movement occurs</p> |
|  <p>Lower</p> | <ul style="list-style-type: none"> ● Bucket lip moves downward to dump ● Lift arms lower |
|  <p>Raise</p> | <ul style="list-style-type: none"> ● Bucket lip moves downward to dump ● Lift arms rise |
|  <p>Dump</p> | <ul style="list-style-type: none"> ● Bucket lip moves downward toward dump position. |
|  <p>Rollback</p> | <ul style="list-style-type: none"> ● Bucket lip continues movement toward dump. |

| | |
|--|--|
|  | <p style="text-align: center;">Rollback is actuated and held:</p> <p>While these conditions exist:</p> <ul style="list-style-type: none"> ● The lift arms are above “ground level” ● Bucket Auto Level is ON. Bucket is level ● The Rollback is commanded (Roller moved backward and held) ● Bucket lip begins movement upward |
| <p>Then a command is initiated by right joystick movement</p> | |
| <p>100% Command</p> | <p>This movement occurs</p> |
|  <p style="text-align: center;">Lower</p> | <ul style="list-style-type: none"> ● Lift arms move downward ● Bucket lip moves upward to full rollback |
|  <p style="text-align: center;">Raise</p> | <ul style="list-style-type: none"> ● Lift arms move upward ● Bucket lip moves upward to full rollback |
|  <p style="text-align: center;">Dump</p> | <ul style="list-style-type: none"> ● Bucket lip continues movement toward rollback position. |
|  <p style="text-align: center;">Rollback</p> | <ul style="list-style-type: none"> ● Bucket lip moves upward to full rollback |

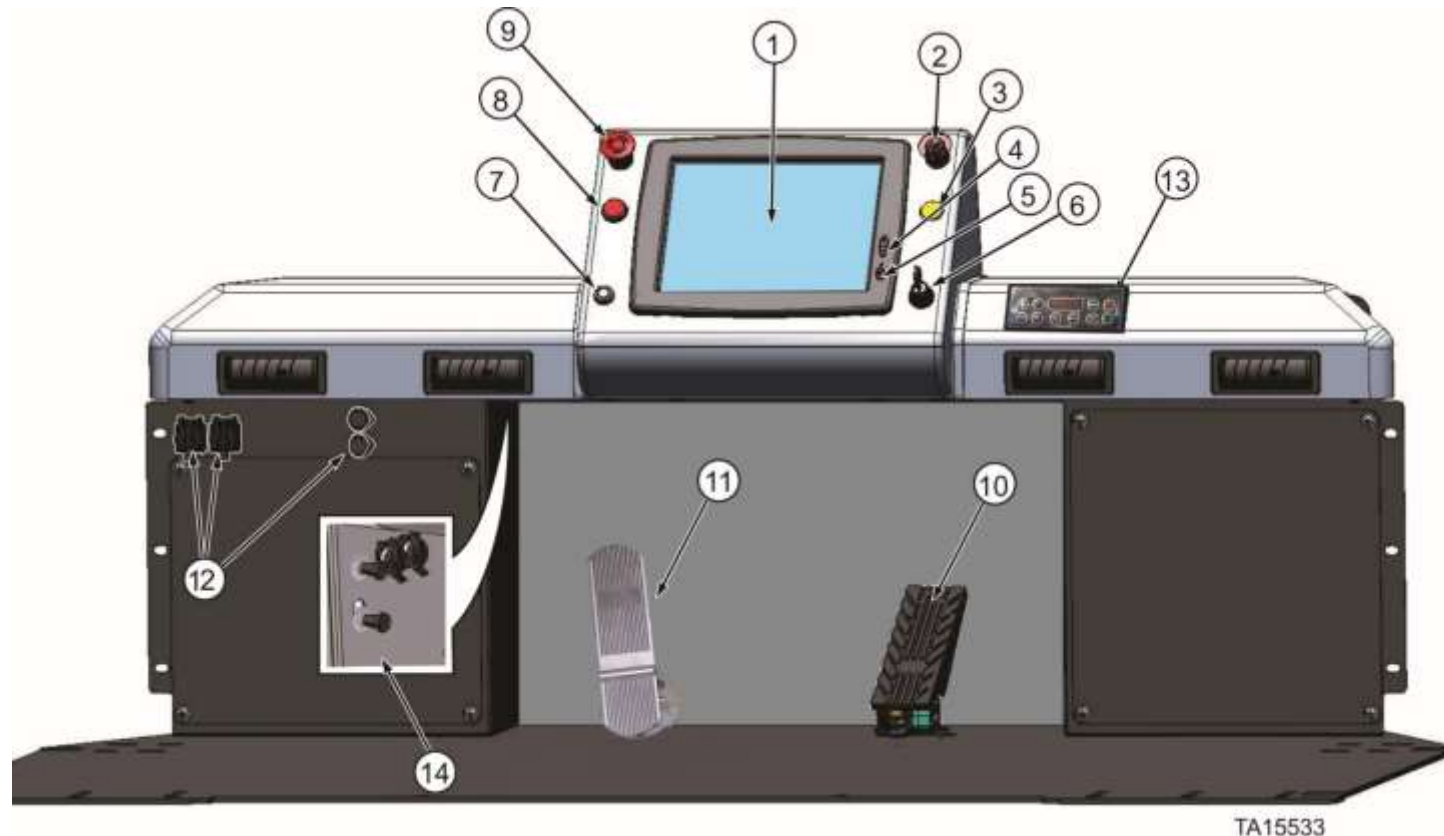

- | | |
|---|--|
| <ul style="list-style-type: none"> 1. LINCS II Touch Screen 2. Park Brake Switch 3. Yellow Warning Light 4. Monitor Display Dimmer/Reset Switches 5. NOT USED 6. Key Switch/Crank Switch 7. User Access Key Reader | <ul style="list-style-type: none"> 8. Red Alarm Light 9. Cab Emergency Stop Switch 10. Speed Control Pedal 11. Service Brake 12. 12V Power-Ports, USB and Ethernet Terminals 13. Cab Environmental Controls 14. Port Location (earlier models) Not Shown: 24V Maintenance Horn (if present) |
|---|--|

Figure 3. Cab control console

This Page Intentionally Left Blank

Cab Control Console (Operator's Console)

(Refer to illustration "Cab control console")

The Operator's Console contains the following:

1. LINCS II Touch Screen
2. Park Brake Switch
3. Yellow Warning Light
4. Monitor Display Dimmer/Reset Switches
5. NOT USED
6. Key Switch/Crank Switch
7. User Access Keypad
8. Red Alarm Light
9. Emergency Stop Switch
10. Speed Control Pedal
11. Service Brake
12. 12V Power-Ports, USB and Ethernet Terminals
13. Cab Environmental Controls

LINCS II Touch Screen

(#1 Illustration on "Cab control console")



The LINCS II screen is a touch screen unit. Touching the various icons with a finger or stylus operates the system's various functions and navigation from screen to screen.

The monitor is a resistive touch screen that responds to finger touch.

Clean the monitor's touch screen periodically to keep the display image bright and sharp, and to keep the touch screen functions working properly. First, attempt to clean the screen with a dry soft cloth.

When cleaning the screen, a "clean screen" feature is built-in to allow for dry dusting of the screen. This feature deactivates the "touch" feature of the screen for a few seconds. Refer to "Clean Screen" for information about activating this feature before cleaning.

If the screen is too dirty to dust clean, a wet cleaner can be used. ALWAYS turn the monitor off before wet cleaning it. Wet cleaning is normally performed prior to shift startup. Use of approved cleaners such as mild glass or window cleaner (ammonia free) with a soft cloth is recommended. If optimum cleaners are not available, use a soft cloth with water and mild detergent. Never spray the monitor with a cleaner. Lightly moisten the soft cloth and gently wipe the screen clean.

CAUTION

NEVER use any cleaners with Ammonia. Using unapproved cleaners can cause component damage. Excessive moisture of any type can damage components. Do not allow liquids to run down to the bottom of the screen at any time. Use mild soap and water to clean screen.

NOTICE

The LINCS II screen illustrations herein are typical examples. Due to software updates, actual screens may be different than those shown in the following text.

NOTICE

If the touch screen is not functional, the vehicle can still be fully operated to navigate to a nearby repair facility. This should be done only in an emergency, using extreme safety precautions that would be set by local management.

Log On

Log On is the way a user can apply their individual preferences in LINCOS-II. Log On is done with the User Access Key. The User Access Key contains information about the user preferences and security level. The machine can be operated without a User Access Key. However, without it, the user preferences must be manually entered into the machine.

When a machine is turned on, it operates with a set of default preferences until they are changed. (Default preferences are set by a Maintenance Level User.). User preferences can be changed at any time by using a User Access Key or by accessing the User Preferences Screen. Changed preferences are active until LINCOS-II is restarted or until a new User Access Key is used. When a User Access Key is used, an event is stored in the Event Log with the User Name and time.

The following are the user preferences stored in the User Access Key:

1. Language
2. Unit System
3. Clock Format
4. Access Level

The different User Access Levels (i.e. Operator, Maintenance, etc.) allow access to different menus and different LINCOS II functions.



Figure 4. User access key and reader

Using the User Access Key

To use a User Access Key, press and hold the key into the reader. The Password Entry Screen should appear within three seconds. If the Password Entry Screen does not appear, remove the key and try again. If an older generation key (LINCS I-Button) or a blank key is used, a notice will appear on the screen.

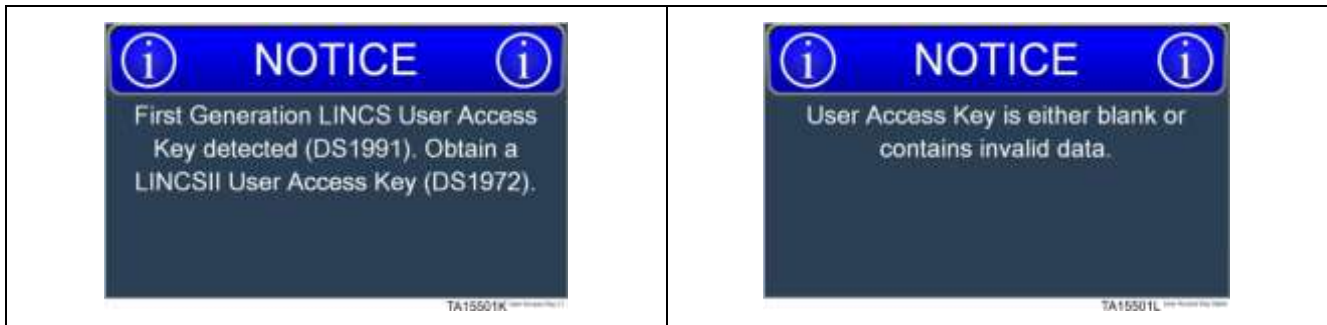

Password Entry Screen

The Password Entry Screen appears after the User Access Key is pressed in the reader. It is used to select the User Access Level and the User Preferences. Each User Access Level allows that user access to various levels of machine component function. The onscreen menu is used to type in the password, by touching numbers. After entering the password, touch the Accept Button (green check box).

⚠ WARNING

Crush hazards exist from unexpected machine movement if settings are changed during actual loading operation cycle. DO NOT set or change any settings during an actual loading operation or cycle. Before entering any information, or making/changing any settings on any screen in the LINCS system, ensure the machine is in an area clear of ALL hazards and personnel. Failure to do so could result in unexpected machine movement, resulting in serious injury or death to personnel.



1. Displays the name stored in the User Access Key.
2. Displays a masked password entered from the onscreen keypad.
3. The Backspace Button is used to backspace a character when entering the password.
4. The Cancel Button is used to exit the screen and reset the User Access Level to Operator.
5. The Accept Button is used after the password is entered.

Alarm, Warning, and Notice Screens

LINCS-II notifies the operator with a message on the display when significant events occur.

Red Alarms

An ALARM is a serious event that means immediate danger to equipment or personnel. The red light on the console turns on, the beeper sounds, and an ALARM message is displayed. The machine should be safely shut down immediately.

Alarms may result in automatic functions to assist the operator in shutting down the machine. When some alarms occur, the Engine automatically goes to low throttle. Typically, a timer appears at the top of the display that gives the minutes until the engine is stopped and the Park Brakes are set. The timer can be manually cleared (and the Engine stopped) by pushing in the Park Brake switch.

The operator can acknowledge the Alarm by pressing the Acknowledge Switch on the left joystick.

Pressing and holding the acknowledge button for two (2) seconds will bypass the engine shutdown timer.



Yellow Warnings

A Yellow WARNING means the equipment has experienced a fault that affects the standard operation and requires an immediate shut down. The yellow light on the console turns on, the beeper sounds, and a WARNING message is displayed. The machine should be safely moved to a safe location and then shut down.

Some Warnings result in automatic changes in machine operation. As examples, over-temperature conditions in the Traction Drive System may result in reduced Motor Torque.



Blue Notices

A NOTICE provides information to the operator as an aid to normal operation. The Notice message will automatically clear after a few seconds. The operator can clear the display early by pressing the Acknowledge Switch on the left joystick.



“Stacked” Alarms, Warnings, and Notices

It is possible to have multiple Red Alarm, Yellow Warning, or Blue Notice screens stacked on top of each other.

“Stacked” Counter Number (Alarms, Warnings, or Notices)

When multiple screens are stacked on top of each other, there is a number in the lower right hand bottom of the screen that counts the total number of screens stacked.

- Each screen must be acknowledged.
- As each screen is acknowledged, the counter number counts downward until all the screens are acknowledged.

In the following example, a Red Alarm was artificially generated and acknowledged.

- Acknowledging the Red Alarm leaves a red “banner” at the top of the screen.
- This particular Red Alarm has a 15 minute countdown as shown by the numbers in the middle of the banner.
- When the counter reaches 00, a sequence of actions occurs and the engine shuts down.

In the following example illustration screen, a combination of 33 Warnings and Notices were artificially created to demonstrate the displayed number (33).

- As the acknowledge button is pressed, the number counts downward until all screens are acknowledged.

NOTICE

The touch screen is deactivated to touch when a Yellow Warning is being displayed on the screen. ALL Red Alarms, Yellow Warnings or Blue Notices must be acknowledged, by using the Acknowledge Button, before the screen becomes active to touch again.

Blue Notices will eventually remove themselves from the monitor screen. They have a timed delay before automatic removal. They can also be manually removed by using the Acknowledge Button.



Figure 5. Countdown number on screen (alarms, warnings, notices)

Main Operator Screen (Menu Navigation)

When LINC S II is started the Main Operator Screen is displayed at the Operator level. Operator, Maintenance or Service personnel can log onto the system with the use of their personalized User Access Key. A User Access Key is not required to operate the machine. While LINC S II is initializing, various information screens will appear.

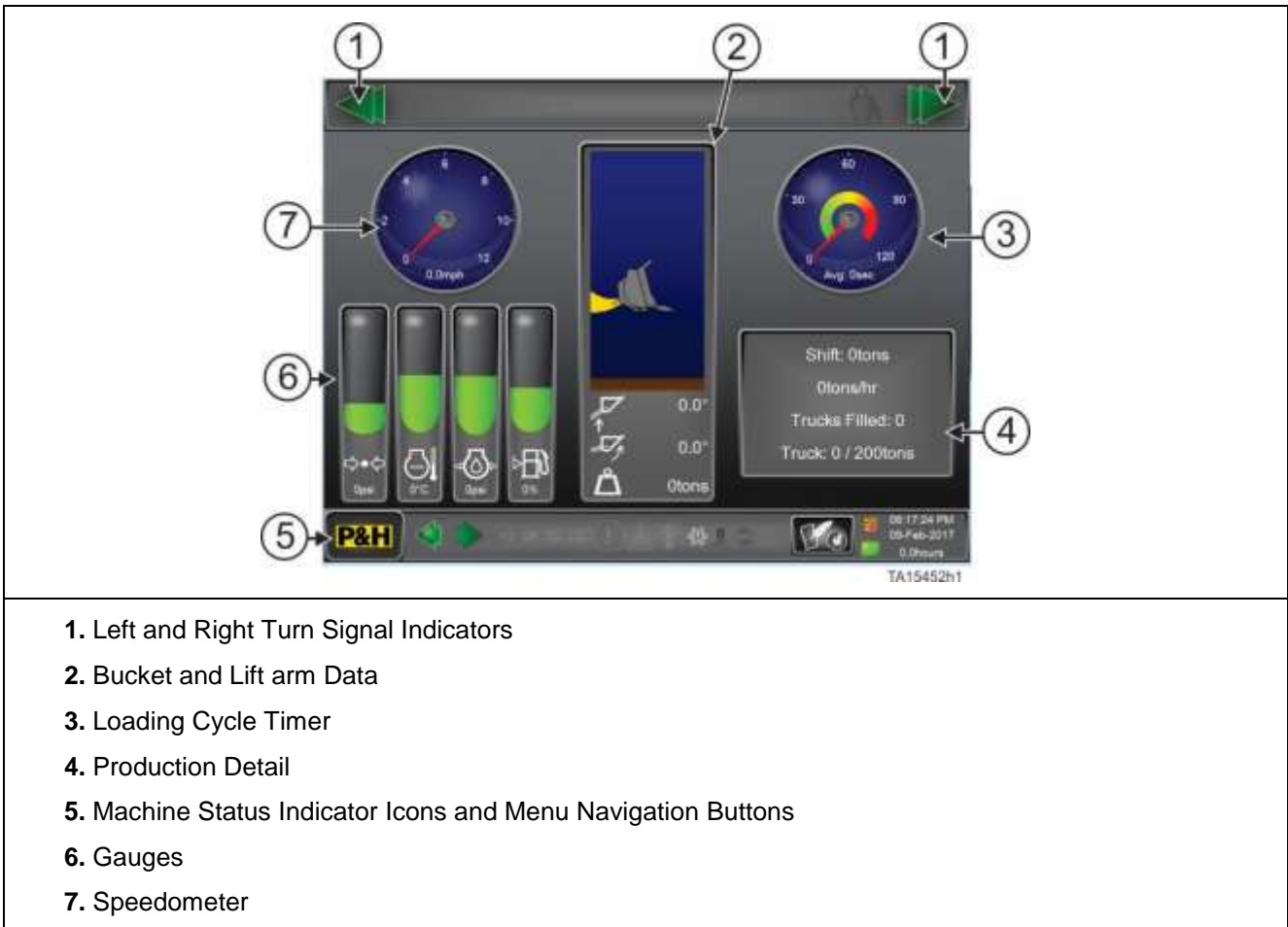
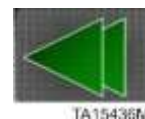

Figure 6. Main operator screen

Left and Right Turn Signal Indicators

The left and right turn signal indicators blink when the turn signal is active. The turn signal buttons are located at the top of the left joystick. The turn signal will cancel when the machine is steered straight.



Bucket and Lift Arm Data

Provides current bucket angle, lift arm angle, and weight in the bucket.

The bucket and lift arms are shown in an image that mimics the actual machine angles. The image changes continually as the machine angles change. The indicator moves up and down to indicate the up and down movement and angle of the machine bucket and lift arms.

The bucket image is calibrated with the Zero Tooth to Ground button located on the User Preferences Screen.



TA15501P Bucket and Liftarm Data



UNDERLOADED



NORMAL LOAD



OVERLOADED



TA15501Q1 bucket loading

CRITICAL OVERLOAD

The bucket picture changes with the amount of weight loaded. Increasing quantity is represented by an enlarging representation of the loaded material. The material color changes according to weight. No colored load indicates an empty bucket. Green indicates a NORMAL LOAD. Yellow indicates the machine is OVERLOADED. Red indicates a CRITICAL OVERLOAD. The CRITICAL OVERLOAD material flashes from light to dark red color.



- A Lift arm Angle measurement indicates the angle of the lift arms as compared to the machine frame.
- The Lift arm Angle is zero (0.0°) when the lift arms are horizontal. A positive angle (+°) is shown when the lift arms are above the zero position and a negative angle (-°) is shown when the lift arms are below the zero position.



- The Bucket Angle measurement shows angle of the bucket as compared to the machine frame.
- The Bucket Angle is usually near zero (0.0°) when the bucket is flat and level with the ground. But the actual “zero” of the Bucket Angle can be changed by the operator. So Bucket Angle measurement may show zero even when the bucket is not horizontal.
- The Bucket Angle zero (0.0°) is set with the “ZERO TOOTH TO GROUND” setting located on the User Preferences Screen.
- A positive angle (+°) is shown when the bucket teeth are above the zero position and a negative angle (-°) is shown when the bucket teeth are below the zero position.
- Refer to “ZERO TOOTH TO GROUND” for more information.



- The Weight measurement shows the current material weight in the bucket. The data can also be displayed in metric units by navigating to the User Preferences Screen and selecting metric units.
- The Weight measurement resets when the bucket is dumped after a completed dump cycle.

Load Weight

- A load weight will be registered during a load cycle if the following parameters are met:
 - The lift arms are below horizontal.
 - The lift arm height and bucket angle meet predetermined height and angle requirements.
 - The bucket contains at least the minimum load needed to register a load weight.
 - No commanded movement (by the right joystick) to the lift arms or bucket.
- A load weight will also be registered if the lift arms are hoisted above horizontal and a previous load weight has not been registered during this load cycle.

Loading Cycle Timer



The Loading Cycle Timer indicates the length of a loading cycle. A loading cycle is the time recorded between two bucket dumps. A bucket dump is defined as a loaded bucket being rolled forward past 10 degrees down of the machine frame angle.

Load Cycle Times

- The current and average cycle times are displayed on an analog and digital gauge, which resembles a stop watch.
- The Loading Cycle Timer provides, in analog format (1. gauge needle), data for the current load cycle.
- The timer provides, in digital format (2. Avg:), the average time based on previous load cycles.
- The Ideal Cycle Time (3) is located at the top center of the analog gauge. This value can be changed by selecting Ideal Cycle Time on the User Preferences Screen.
- Current cycle times can be quickly identified as adequate or inadequate because the gauge has a colored indicator bar for; fast (green), adequate (yellow) and slow loading cycle time (red).
- Average cycle times are based on previous cycle times. This average can be reset by selecting the Reset Shift Production button on the User Preferences Screen.

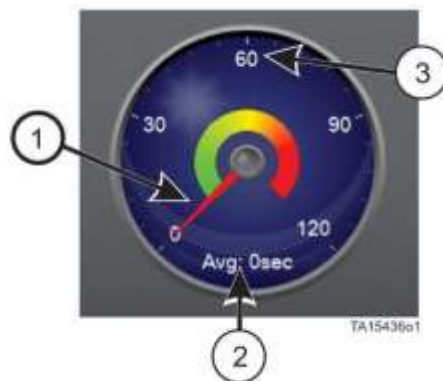

1. Analog Format Current Cycle Times
2. Digital Format Average Cycle Times
3. Ideal Loading Cycle Time

Shift Production Data

Provides information about the operator's and loader's productivity.

The Shift Production Data is displayed in four indicators:



- **Shift** – displays the weight of the material loaded during the shift (tons).
- **Productivity** – displays the number of tons loaded per hour during the shift.
- **Trucks Filled** – indicates the number of trucks loaded during the shift.
- **Truck** – displays current weight of truck being loaded (tons). This value is reset by pressing the horn button on the right joystick.
- The size of the truck is set on the User Preferences Screen by selecting Truck Capacity.
- The unit system (Imperial or Metric) for indicating weight is set on the User Preferences Screen by selecting Unit System.

NOTICE

Selecting Reset Production Data on the User Preference screen will set the Shift Production Data to zero. The size of the truck selected will not be changed.

Machine Status Indicator Icons and Menu Navigation Buttons



Some of these icons only appear if the machine is operating in an abnormal mode.



Main Menu Button

Provides access to various options.

- 1) Operator/User Preferences
- 2) Data Logging
- 3) Machine Summary
- 4) Main Operator
- 5) Located in the left corner of the touch screen



Backward and Forward Button

Moves the user selection forward or backward one screen to the Next or Previous screen.



DEF System Level (Equipment with DEF systems only)

This icon lit up Indicates that some part of the engine exhaust system is in an abnormal state.



Torque Limited (Equipment with DEF systems only)

The presence of this icon Indicates that some part of the traction system in an abnormal state.



Check Engine (Equipment with DEF systems only)

The presence of this icon Indicates that some part of the engine system in an abnormal state.



Stop Engine (Equipment with DEF systems only)

The presence of this icon Indicates that some part of the engine system in an abnormal state.



TA15436D4

Alarm

The red Alarm Icon appears on the screen when an Alarm occurs and the Alarm Message is displayed. The Red Lamp on the dash illuminates and an audible alarm sounds at the same time. Touching the Alarm Icon selects the Event Screen and displays the list of the most recent alarms. The Alarm Icon remains on the screen after the Alarm Message is acknowledged until the condition that caused the alarm is corrected



TA15436D5

Warning

The yellow Warning Icon appears on the screen when a Warning occurs and the Warning Message is displayed. The Yellow Lamp on the dash illuminates and an audible alarm sounds at the same time. Touching the Warning Icon selects the Event Screen and displays the list of the most recent warnings. The Warning Icon remains on the screen after the Warning Message is acknowledged until the condition that caused the warning is corrected.



TA15436D6

Channel Forced

The presence of the Forced Channel Icon indicates that at least one of the LINCS-II channels has been manually changed.



TA15501V

Drive System Abnormal

The presence of this icon Indicates that some part of the traction system is in an abnormal state.



TA15501W

Drive Programming

The presence of this icon Indicates that the Drive Control Boards are being programmed.



TA15436D7

Limits Bypassed

The Limits Bypassed Icon appears on the screen when any limits are bypassed such as the Hoist Up Limit. Touching the Limits Bypassed Icon will display the Machine Settings Screen if the user has adequate access.



TA15436D8

Load Bank

The Load Bank Icon appears on the screen when the machine has been placed in the Load Bank testing mode.



User-Defined Event Button

This button generates a User Defined Event that is recorded in the Event Log.



Database

When this icon appears, the database is not actively downloading channel and event files.



Database Downloading Files

When this icon appears, this database is downloading channel and event files.



Database Caught Up

When this icon appears, the database is caught up on all channel and event files.



Connection Status LED Icon

Light Green: Indicates a working connection between the HMI and VCU.

Yellow: Indicates a disrupted connection between the HMI and VCU.

Dark Green: Indicates the HMI and VCU are disconnected.

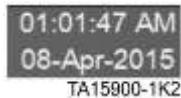

Date/Time

Displays the current date and time.



Machine Hours

Indicates the total engine run time.

Gauges (6)



Oil Pressure Gauge

- The Oil Pressure Gauge provides analog and digital display of the engine's oil pressure.
- The digital display's unit system (Imperial or Metric) is set on the User Preferences Screen by selecting Unit System.

NOTICE

When operating in cold climates, the oil pressure indicator will be higher after starting during engine warm-up. In cold climates, it takes longer for the oil to warm-up and for the oil pressure to reach normal operating range.



Coolant Temperature Gauge

- The Coolant Temperature Gauge provides analog and digital display of the engine's coolant fluid.
- The digital display's unit system (Imperial or Metric) is set on the User Preferences Screen by selecting Unit System.



Oil Pressure Gauge

- The Oil Pressure Gauge provides analog and digital display of the engine's oil pressure.
- The digital display's unit system (Imperial or Metric) is set on the User Preferences Screen by selecting Unit System.

NOTICE

When operating in cold climates, the oil pressure indicator will be higher after starting during engine warm-up. In cold climates, it takes longer for the oil to warm-up and for the oil pressure to reach normal operating range.



Fuel Gauge

- The Fuel Gauge provides analog and digital display of the amount of fuel in the fuel reservoir.
- The digital display indicates the percent (%) full. For example, if the reservoir can hold 500 gallons of fuel, 50% indicates that the reservoir contains 250 gallons of fuel.

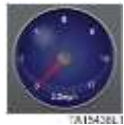

Speedometer (7)

- The Speedometer provides analog and digital display of the machine speed.
- The Speedometer indicates the speed in both forward and reverse directions.
- The display's unit system (Imperial or Metric) is set on the User Preferences Screen by selecting Unit System

Menu Selections

- Touching the Main Menu Button displays the Main Menu Selections. Touch a Main Menu item to select the screen or function. The list of menu items varies depending on the security level of the User Access Key. Menu items containing a red arrow have sub-selections. Touch the menu item to display the submenu.



Main Menu Sub-Selection

Touch the Main Menu Button to display the Main Menu. The top item in the list contains the name of the user who is currently logged on. Touching the user's name displays the submenu where the user can select either the User Preferences Screen or Log Off. Selecting Log Off will set the User Access to the default Operator level.



User Preferences Screen

The User Preferences Screen allows the user to change LINCX-II screens are displayed, test machine functions and adjust the Alternate Speed and Torque settings.

Items 1- 4, 12 & 13 have arrows at each end of the selector that are used to change the selection.

The screenshot shows the User Preferences screen with the following settings and controls:

- 1:** Language (English)
- 2:** Unit System (Broadcast)
- 3:** Truck Capacity (200tons (181.4tonnes))
- 4:** Ideal Cycle Time (60sec)
- 5:** Display Troubleshooting Notices (checkbox)
- 6:** Lamp Test button
- 7:** Zero Tooth to Ground button
- 8:** Reset Shift Production button
- 9:** Auxiliary Steering Test (Enable/Disable)
- 10:** Brakes Test (Enable/Disable)
- 11:** Inhibit Park Brakes Release Mode (Enable/Disable)
- 12:** Alternate Speed slider (6.0mph)
- 13:** Alternate Propel Torque slider (40%)
- 14:** Typical selection arrows (left and right green arrows)

| | |
|---|--|
| <ol style="list-style-type: none"> 1. Language 2. Unit System 3. Truck Capacity 4. Ideal Cycle Time 5. Display Troubleshooting Notice 6. Lamp Test 7. Zero Tooth to Ground | <ol style="list-style-type: none"> 8. Reset Shift Production 9. Auxiliary Steering Test 10. Brakes Test 11. Inhibit Park Brakes Release Mode 12. Alternate Speed 13. Alternate Propel Torque 14. Typical selection arrows |
|---|--|

USER PREFERENCES SCREEN

For numbers in parenthesis, refer to illustration “User Preferences screen”.

Language (1)

- Touch the arrows to select the Language used for displaying information on the LINCX-II screens.

Unit System (2)

- Touch the arrows to select the Unit System used for displaying values (Metric, Imperial, or Broadcast).
- Broadcast units are a mixture of unit systems that is preferred by the factory.

Truck Capacity (3)

- Touch the arrows to decrease or increase the Truck Capacity as displayed on the Main Operator Screen.

Ideal Cycle Time (4)

- Touch the arrows to change the Ideal Cycle Time which is used as the center value of the Loading Cycle Timer displayed on the Main Operator Screen.
- Touch the arrows to decrease or increase the time value.

Display Troubleshooting Notices (5)

- Touch the box to place a checkmark and select Display Troubleshooting Notices.
- This activates notices not normally displayed such as when the machine stops moving because it has reached a limit.



Lamp Test (6)

- Touching the Lamp Test button turns on the dash Red Alarm light, Yellow Warning lights, and the Cab Audible Alarm.
- The screen button is momentary so the lights and alarm stay on as long as the button is touched.

Zero Tooth to Ground (7)

- Touch the Zero Tooth to Ground button to set the bucket-to-ground angle to zero (0.0°).
- Typically, the bucket is set flat on the ground before setting the angle.
- Set the bucket to the desired angle and press the button to set the angle.

Reset Shift Production (8)

- Touch the Reset Shift Production button to reset the shift production to zeros on the Main Operator screen.

Auxiliary Steering Test (9)

- Touch the Auxiliary Steering Test Enable button to engage the Auxiliary Steering System test mode.
- When left or right steering is commanded, the electric motors that power the steering hydraulics will turn on.
- The motors only operate while the Left Joystick is being used to steer left or right.
- Touch the Disable button to return the Auxiliary Steering System to normal operation.

Brakes Test (10)

- Touch the Brakes Test button to allow the wheel motors to run with the brakes set.
- Forward direction must be selected with the engine running and the drive system enabled.
- The Traction System will engage and the vehicle may move even though the Service and/or Park brakes remain set.
- Touch the Disable button to return the traction system to normal operation.
- Brakes Test is cancelled if the user selects Neutral, selects Reverse, or exceeds low machine speed.

Inhibit Park Brakes Release Mode (11)

- Touch the Inhibit Park Brakes Release Mode Enable button to allow the Park Brakes Switch to be pulled OUT without releasing the park brakes.
- If the Park Brake Switch is pulled OUT, the Park Brake Switch Light will flash and hydraulic operations are allowed (steering, etc.).
- Propel is prevented because the park brakes do not release.
- Touch the Disable button to return the Park Brake switch to normal operation.

Alternate Speed (12)

- Touch the arrows to set the machine Alternate Speed.
- The Alternate Speed is the speed limit used when the Alternate Speed function is engaged.
- Use the overhead control console “Alternate Machine Speed” button to engage the Alternate Speed function

Alternate Propel Torque (13)

- Touch the arrows to set the machine Alternate Propel Torque percent.
- The Alternate Propel Torque is the wheel motor torque percent limit used when the Alternate Torque function is engaged.
- Use the overhead control console “Alternate Propel Torque” button to engage the Alternate Torque function.
- Alternate Torque is used to help prevent the wheels from slipping when operating on a slick surface.
- This feature only reduces propel torque. Full braking torque is unchanged.

Data Logging Menu

Provides access to the Logging/Monitoring and Production Reports screens.



1. Logging/Monitoring

The Logging/Monitoring menu selection provides access to the Charting Screen and the Event Logging Screen.

2. Production Reports

The Production Reports menu selection provides access to the production reports such as Loads, Cycle Times, Loader Activity, etc.

Channel Selection Screen

The Channel Selection Screen provides a means to select data channels for viewing on charts.



NOTICE

A red arrow is normally seen only by Factory rep level; however, it is shown at operator level in some channels.

1. Touch a scroll button to move the group list.
2. Drag the scroll button to scan the group list.
3. Touch a group name to expand the group and show the channels. Touch the group name again to collapse the list. Drag the group name to the right side of the screen to select all the channels in the group. Drag a single channel name to select just one channel. To remove a channel from the selection list, drag the name out of the selected channels box.

NOTICE

The selected channel list can be rearranged by dragging the channel name to a new location.

Channel Types

1. Calculated (derived from other data) shown as a calculator.
2. Input (Analog, Digital, or CAN) shown by a green "in" arrow.
3. Touch the Channel Selection Screen Button to display this screen.
4. Touch the Channel Charting Screen Button to display the selected channels in a chart or plot format.
5. Touch the Event Logging Screen Button to display a list of event records.
6. Touch the Remove All Channels Button to clear the list of selected channels.
7. Touch the Filtering Button to select the amount of noise filtering to be applied to the channel values on the Channel Selection Screen. Selecting "Rabbit" gives light filtering that removes a minimal amount of noise. Selecting "Turtle" gives heavy filtering so the values are more stable.

Logging/Monitoring

Charting Screen

The Charting Screen provides a way to view channel data in a plot or strip chart form. Multiple channels can be displayed showing data “live” (as it occurs) or “history” (from previous time).

Live Data

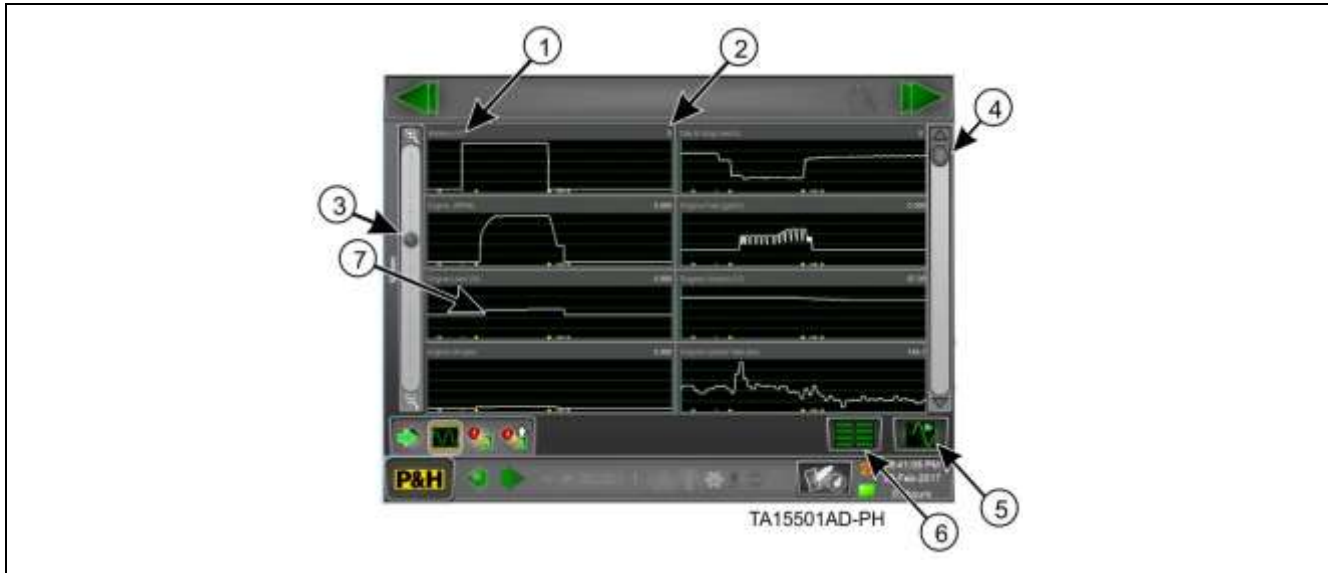

1. Channel Name

The Channel Name is displayed at the top left of a trace.

2. Channel Value

The Channel Value is displayed at the top right of a trace. For live data, the number shows the most recent data. For history data, the number shows the value of the channel measurement based on the position of the orange or blue cursor, or on the selected channel type as described in item #14 below. The vertical scale of the charts is automatically set to fit the selected data.

3. Time Zoom Scroll Bar

The amount of time shown on the display can be changed by dragging the zoom slider button. Drag the button left to zoom out and display more time. Drag the button right to display less time. The amount of data shown in the display will be the data stored in a download. Only 6.97 days is available. By default, the amount of time in the display is 60 seconds.

4. Selection List Scroll Bar

The list of selected channels can exceed the number that is displayed on the screen. Drag the scroll button to sweep through the entire list of selected channels. Touch the arrows at the ends of the scroll bar to move the channel traces one row at a time.

5. Live/History Data Button

Touch the Live/History Data Button to change the display between live (real-time) data and history (recorded) data. Live data is shown as soon as it happens. As time progresses, the trace will advance so that the most recent data is always shown. History data shows a selection of past time.

6. Chart Layout Buttons

The charts can be displayed in a variety of layouts. A single channel can fill the entire view area (1x1) or as many as 16 channels can be displayed at the same time (4x4).

7. Channel Plot

The channel is displayed as a curve plot that varies in height proportionally to the data value. The channels are shown in the same order as listed on the Channel Selection Screen.

History Data

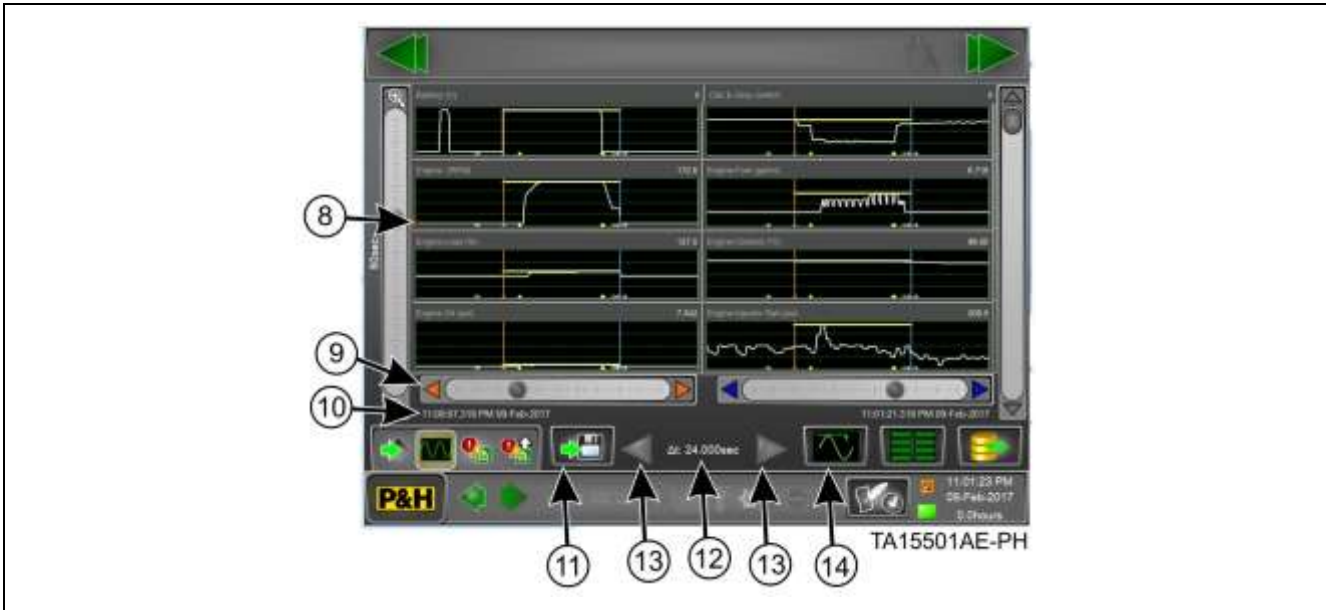

8. Event Markers

Events are indicated at the bottom of a trace. The event type is indicated by the color of the marker (i.e. Red – Alarm, Yellow – Warning). A circle indicates when the event was set (i.e. when the Alarm occurred). A solid dot indicates that the event cleared.

9. Cursor Position Bars

The Cursor Position Bars allow adjustment of the two cursors. The left bar is used for the orange cursor and the right bar is used for the blue cursor. Touch the arrows to adjust the cursors in small steps. Drag the cursor button to pan the time setting.

10. Cursor Timestamps

The Timestamps show the time and date of the two cursors.

11. Download Button

Touch the Download Log Button to display the Download Dialog. (See DOWNLOAD DIALOG.)

12. The Cursor Delta Time (Δt)

The Delta Time is the amount of time between the two cursors.

13. Data Selection Buttons

When the user is viewing history data, they can change the displayed section of data. Touching the left arrow moves the selection to show data earlier in time. Touching the right arrow shows data later in time.

NOTICE

The time selection can also be changed by dragging a trace to the left or the right.

14. Measurement Type Button

Touch the Measurement Type Button to select the type of measurement used for the history data. The value of the measurement is shown as the channel value and by a yellow line on the chart.

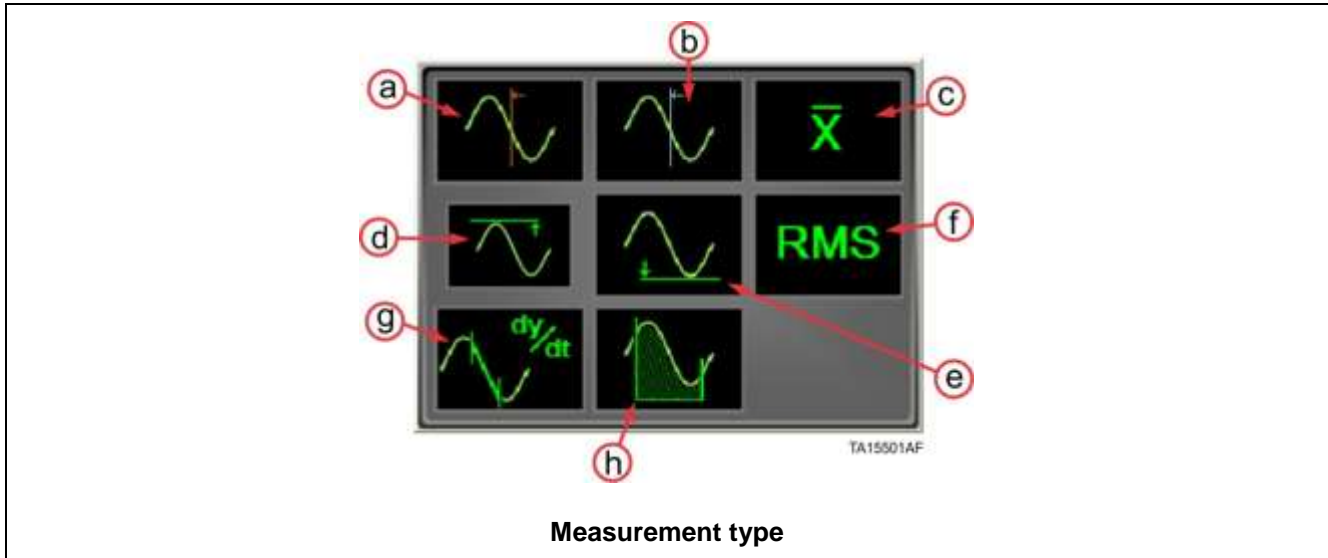

- a. **Cursor 1** is the value of the data at the point where the orange cursor crosses the plot.
- b. **Cursor 2** is the value of the data at the point where the blue cursor crosses the plot.
- c. **Average** is the average of the values between the two cursors.
- d. **Maximum** is peak value of the data between the two cursors.
- e. **Minimum** is the valley value of the data between the two cursors.
- f. **RMS** is the root-mean-squared value of the data between the two cursors.
- g. **dy/dt** is the slope of a line between the two data points that are marked by the two cursors. The slope is a measure of the change in amplitude of the data divided by the time between the two points.
- h. **Area Under Plot** is the sum of all the data values between the two cursors times the time (the integral). It could be used to determine the total fuel used in a load cycle by measuring Engine: Fuel Rate.

Event Logging Screen (Detailed)

Event logging provides a method for viewing events such as Alarms, Warnings, and Alerts.



1. Select Alarms Button

Touch the Alarms Button to show Alarms in the list. The button will be bright red when Alarms are displayed and faded grey when alarms are not included. The five Select buttons can be applied separately or together.

2. Select Warnings Button

Touch the Warnings Button to show Warnings in the list. The button will be bright yellow when Warnings are displayed and faded grey when they are not included.

3. Select Alerts Button

Touch the Alerts Button to show Alerts in the list. The button will be bright blue when Alerts are displayed and faded grey when they are not included.

4. Select Events Button

Touch the Events Button to show Events in the list. The button will be bright grey when Events are displayed and faded when they are not included.

5. Select Production Data Button

Touch the Production Data Button to show Production Data in the list. The button will be bright green when Production Data is displayed and faded grey when not.

6. Date Range Button

Touch the Date Range Button to change the date range used for the event list. The range is selectable by day, month, and year.

7. Page Button

The Page Buttons allow the user to navigate through sections of 100 events at a time. Touch the bottom Page Button to display the next page of older events, going back in time. Touch the top Page Button return to the next page of more recent events.

8. Scroll Buttons

Use the Scroll Buttons to navigate the event list.

9. Chart Select Button

Touch the Chart Select Button to select the event and navigate to the Charting Screen. The selected event will be centered in the chart. Events that do not have associated charting data are shown with a grey Chart Select Button.

10. Date and Time Stamp

The Date and Time Stamp show when the event happens. If multiple events have the same time stamp, they are logged in the order they occurred.

11. Detailed/Summary View Button

Touch the Detailed/Summary View Button to switch between the detailed and summary views. The Detailed View shows the occurrence each event with the Date and Time Stamp.

12. Event Group (Total Events) Maximum of 2000

The Event Group is the event numbers that are currently available with the scroll buttons. The Total Events (in parentheses) is the total events available for viewing.

13. Download Button

Touch the Download Log Button to display the Download Dialog. (See DOWNLOAD DIALOG.)

14. Event Select Box

Touch the Event Select Box to select event types for focused viewing. The event list becomes reduced to only the selected events when the Filter Button is touched.

15. Set Event Indicator

A white up arrow on the event type image shows that this is a Set Event. The Set Event time is when the event occurred.

16. Cleared Event Indicator

A black down arrow on the event type image shows that this is a Cleared Event. The Cleared Event occurs when the triggering condition is resolved. For example, this happens when a fault is corrected.

17. Filter Button

Touch the Filter Button to limit the list of events to the event types that have been selected. All other events are filtered out of the list.



Event Logging Screen (Summary)

The Summary View shows a summary that gives the total occurrences of each event type in the history log. The numbers indicate only the number of events that occurred within the selected Date Range. The Summary View is sorted with the most frequent event listed at the top.



Download Dialog

History logs can be downloaded (copied) to a USB memory device (flash drive only) plugged into the USB port in the cab. The log will contain a copy of all the events currently recorded by LINC-II. The log can optionally contain a section of channel data recorded.

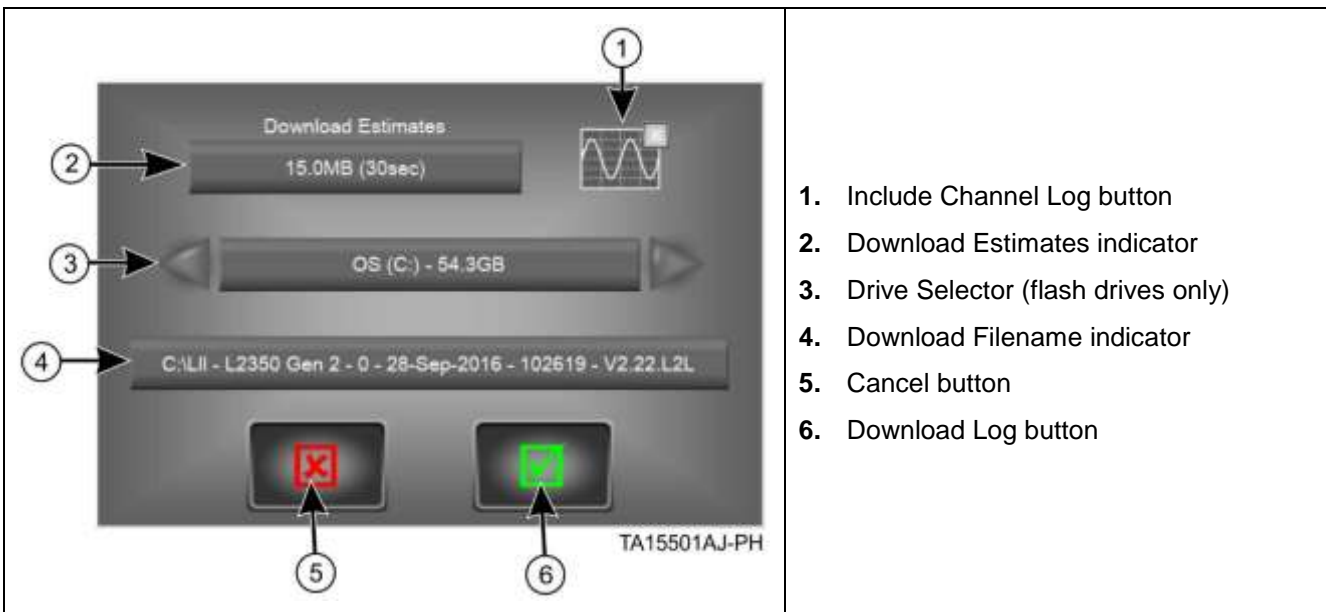

1. Include Channel Log button
2. Download Estimates indicator
3. Drive Selector (flash drives only)
4. Download Filename indicator
5. Cancel button
6. Download Log button

1. Include Channel Log button

Touch the Include Channel Log button to include the channel data in the log. The time span of the channel data will be the time previously viewed on the Channel Charting screen. A zoomed-in chart (less time) will result in a smaller log file.

2. Download Estimates indicator

This displays the approximate size of the download and the approximate time it will take to send the file to the USB device.

3. Drive Selector (flash drives only)

Touch the Drive Selection arrows to pick the target USB device. LINCOS-II automatically recognizes USB devices when they are plugged into the USB port in the cab. The bar shows the USB device's name and the amount of empty space.

4. Download Filename indicator

The path and filename are automatically provided.

5. Cancel button

Touch the Cancel button to close the dialog box and cancel the download.

6. Download Log button

Touch the Download Log button to start the download. A progress bar will appear on the screen. Do not disturb the USB memory device while the download is in process.

NOTICE

When the progress bar disappears, the USB device can be removed.

Download Procedure

Insert a USB flash drive into the USB port in the cab. The USB port will either be located under the dash on the left hand side above the service brake panel, or it will be located on the front of the dash on the left hand side.

1. Determine if channel data is required. If no channel data is required, go to "Log File Downloads".
2. Navigate to the Data Logging menu.
3. Select Logging/Monitoring.



4. Select at least one channel and drag it to the Channel Selection screen on the right side of the screen.



5. Touch the Channel Charting screen button to display the selected channel(s) in a chart or plot format.



6. Touch the Live/History Data button to display history (recorded) data.



7. Adjust the Time Zoom scroll bar to the required time setting. Only data on the screen will be downloaded. Example; if the Time Zoom is set at 60 seconds, the channel data downloaded will only be 60 seconds.



8. Locate the data that is desired to be downloaded. To locate the data, scroll the charts until the desired chart information is displayed. If an exact time and date of the data is known, watch the cursor time and date change as the chart is scrolled.



NOTICE

In the example above, the time zoom is set at 15 minutes, the channel data downloaded will be the 15 minutes shown on the screen.

9. Touch the Download button.

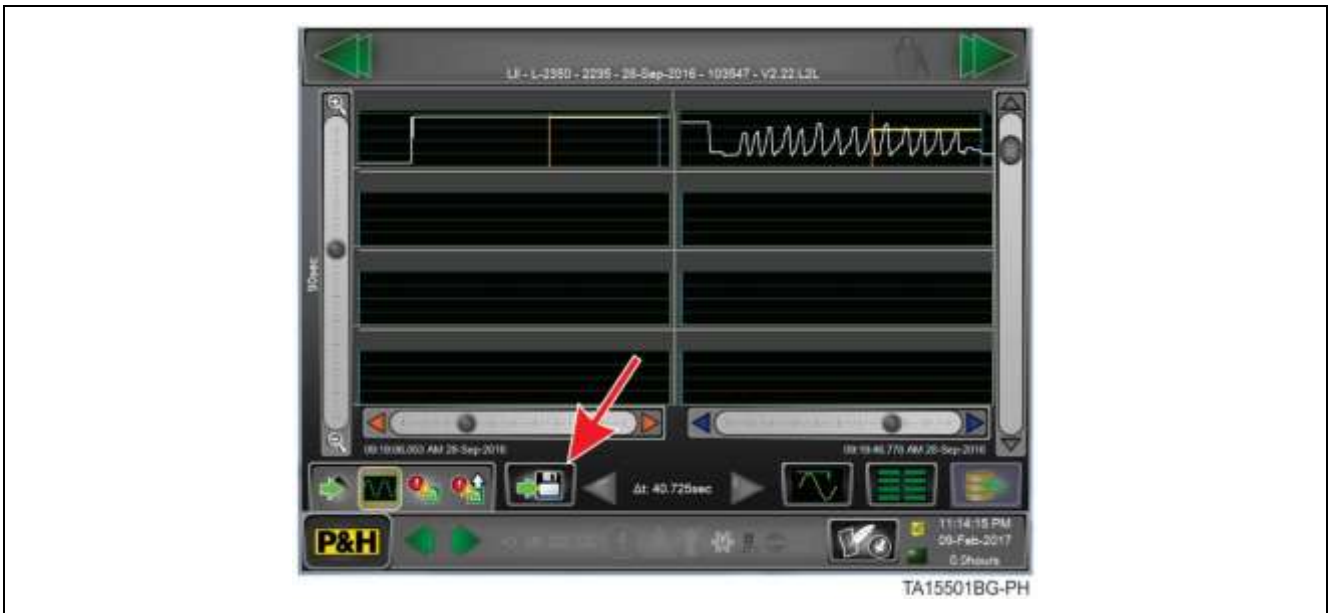

10. Once the Download Dialog box is open, touch the box to include channel data. A check mark (Item #1) will appear if channel data will be included.

| | |
|--|--|
| | <ol style="list-style-type: none"> 1. Include Channel Log Button 2. Download Estimates 3. Drive Selection (flash drives only) 4. Download Filename 5. Cancel Button 6. Download Log Button |
|--|--|

NOTICE

IF NO channels have been previously chosen (steps 4 thru 8), and the download dialog box is opened and the box is checked to have channel data included, the download WILL NOT have any data associated with it. If this download file is opened, the date on the channel data will read the year 1903 or 1904.

11. Select the destination drive letter (Item #3). The file name is automatically generated and cannot be changed prior to the download. After the download is done, the file name may be changed following standard file renaming perimeters (Item #4).

| | |
|--|--|
| | <ol style="list-style-type: none"> 1. Include Channel Log Button 2. Download Estimates 3. Drive Selection (flash drives only) 4. Download Filename 5. Cancel Button 6. Download Log Button |
|--|--|

12. Select the green check mark to start the download (Item #6).

NOTICE

If the selected time zoom setting is at maximum (4 hours) and the download has channel data selected, the download may take up to an hour to complete. An estimated file size and download time is automatically generated (Item #2).

Log File Downloads

1. Navigate to the Data Logging menu.
2. Select Logging/Monitoring



3. Touch the Event Logging screen button.



4. Touch the Download button.



5. Verify that the Chart Data button is grayed out with no check mark.

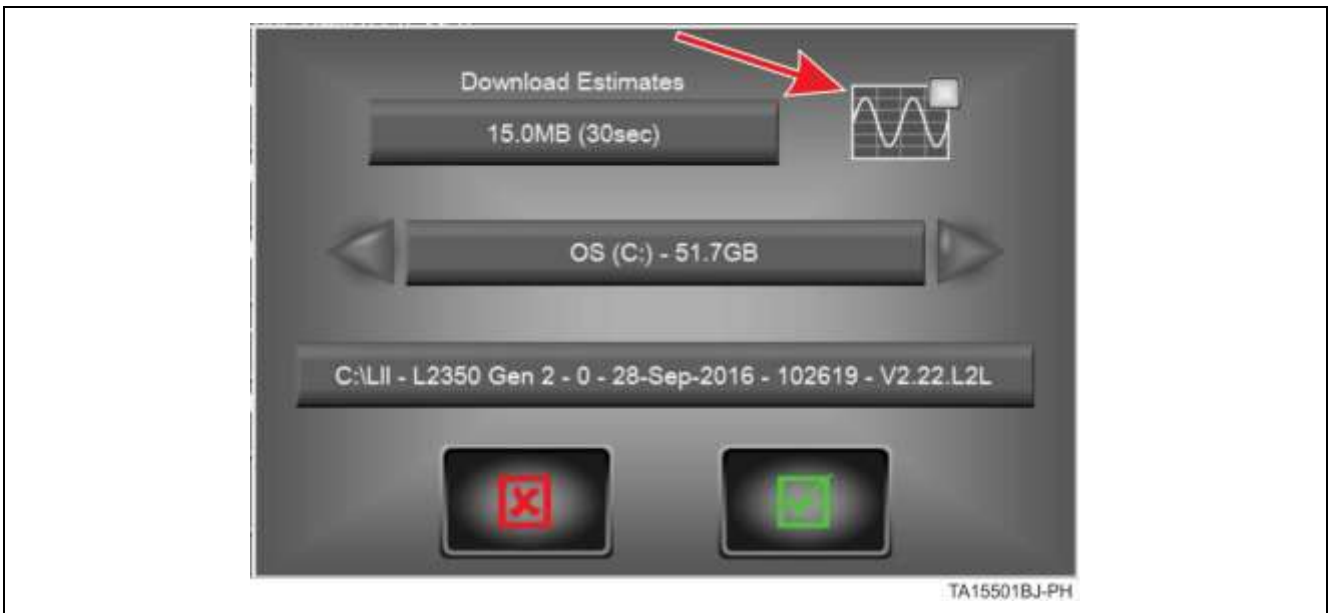

6. Select the destination drive letter.

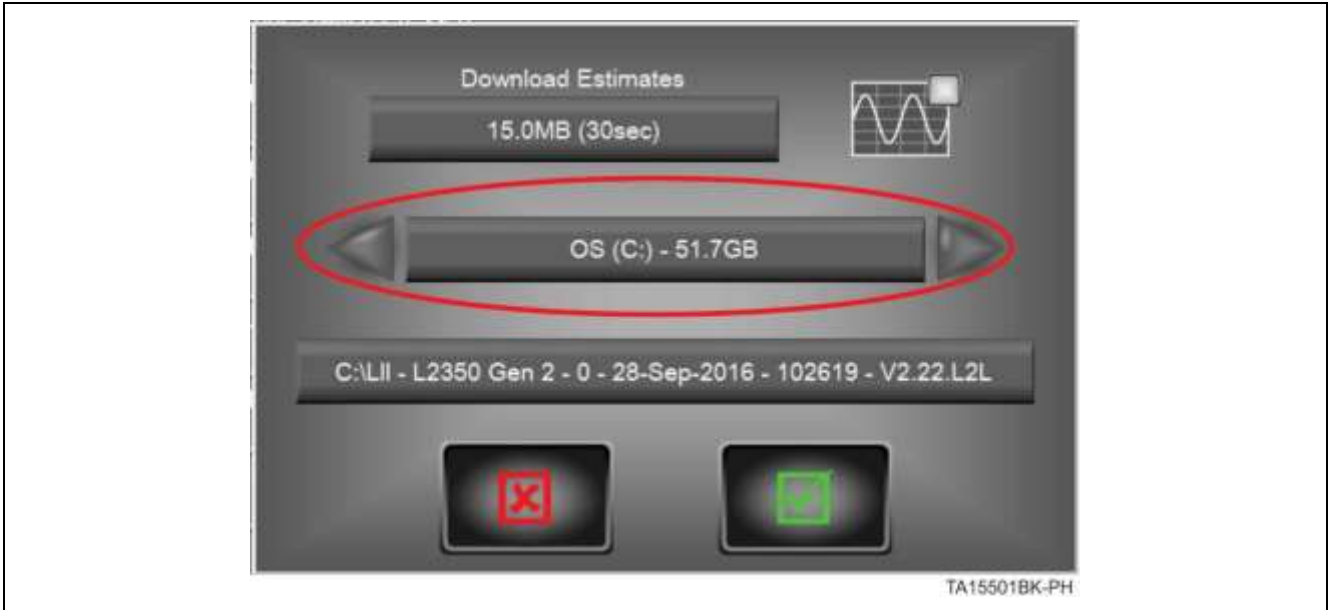

7. Select the green check mark to start the download.

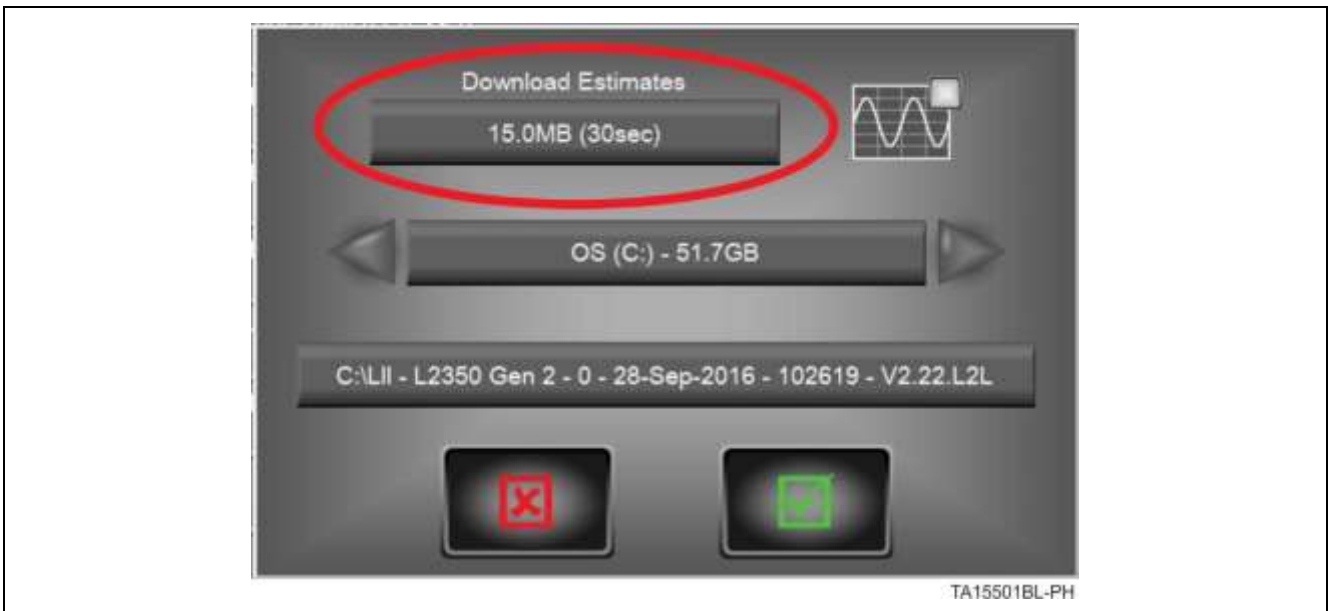

8. Because no channel data is being downloaded, the download should complete in under 10 minutes.

Production Reports

Loads

The Loads report shows the value and time of each load. The left scroll bar selects the time width of the display window. The bottom scroll bar selects the window position in time.

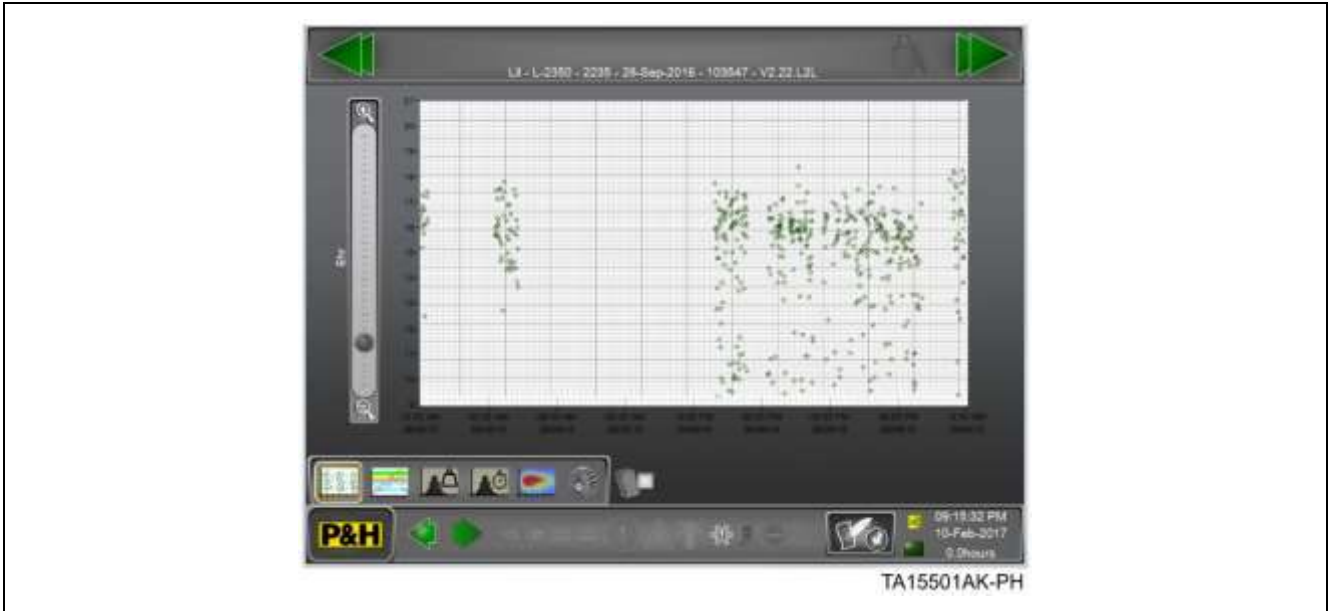

Profile

The Profile report provides a summary of loader activity. The left scroll bar selects the time width of the display window. The bottom scroll bar selects the window position in time.



Tons Per Load

The Tons Per Load report provides a bar chart that shows the number of loads by the load weight value. The data range is selected by touching the Setup Button.



Cycle Times

The Cycle Times report provides a bar chart that shows the number of cycles by the cycle time value. The data range is selected by touching the Setup Button.

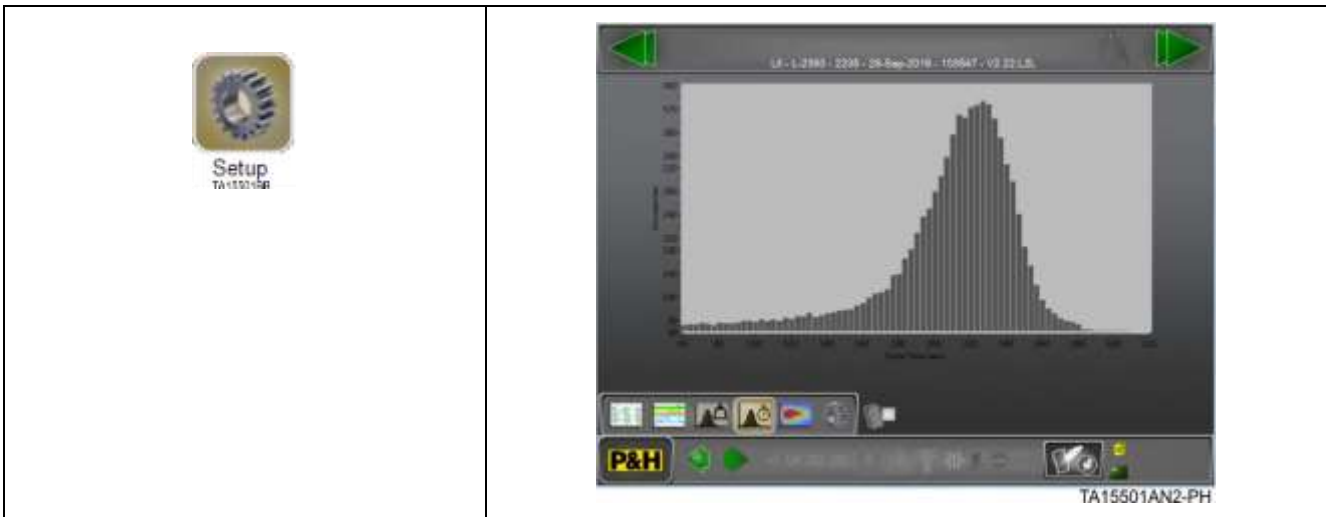

Cycle Time/Load Sweet Spot

The Cycle Time/Load Sweet Spot report provides a 3D bar chart that combines the load and cycle time values. The color chart indicates the number of occurrences for each combination. The data range is selected by touching the Setup Button.

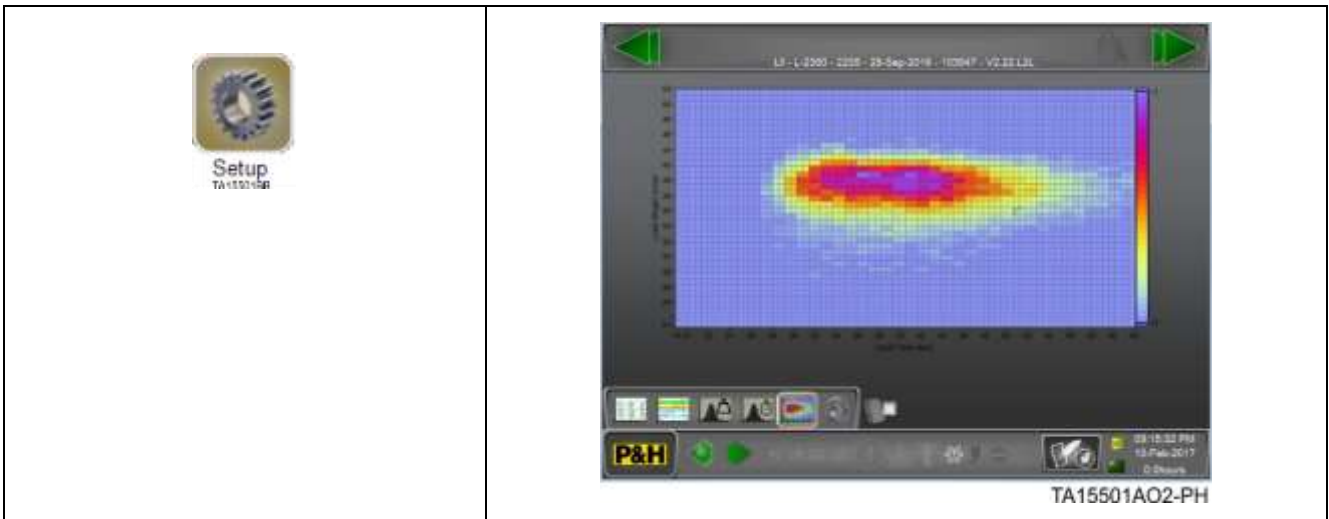

Production Reports Setup

The Production Reports Setup screen allows filtering of the production data to remove spurious values. For example, the Load Weight Minimum can be set to a value that allows the reports to ignore weights recorded when the loader is cleaning up the work site. The Date Range for the reports can be selected by touching the Date Range Button.



Machine Summary

Touch Machine Summary to display a list of general information about the machine. This list includes the Machine Serial Number and the installed options.



Machine Summary Screen

The Machine Summary Screen gives a list of machine settings and options. This screen is for information only. The list contains the following:



- | | |
|---|--|
| <ol style="list-style-type: none"> 1. Machine id (L-1150 - 2001) 2. Engine type (Cummins, Detroit, etc.) 3. Language (English, Spanish, etc.) 4. Unit system (Imperial, Metric, or Broadcast) 5. Clock format (12 hour or 24 hour) 6. Time zone (Local time zone offset from GMT) 7. Time zone locale (Time zone location such as central time – us) | <ol style="list-style-type: none"> 8. Lift arm (Standard Lift or High Lift) 9. Auxiliary steering (Installed or Not Installed) 10. Driver filtration (Installed or Not Installed) 11. Bucket (Standard or Clamshell) 12. Isolation monitor (External or Internal) 13. Software version (LINCS II Software Version) 14. Data source version (Data version) |
|---|--|

Clean Screen

The LINC5-II screen is a touch screen and must be periodically cleaned.

- Clean Screen prevents LINC5-II from responding to a display touch so that the screen can be cleaned.
- Clean Screen should be selected before attempting to physically wipe the screen.
- Once Clean Screen has been selected, a countdown displays showing the number of seconds remaining before the screen returns to normal operation.

The Acknowledge Button on the Left Joystick cancels the countdown.



Figure 7. Clean screen

CAUTION

Damage to the display is possible if it is wetted during operation. NEVER wet clean the screen Turn the display off to clean with a wet process.

Cleaning Procedure

Clean the screen with a clean, dry, soft cloth. If this does not clean the screen adequately, use water or a mild glass cleaner. Do not use a cleaner that contains ammonia. Apply the cleaner to a clean soft cloth and not to the screen. Never use an abrasive cleaner or cloth.

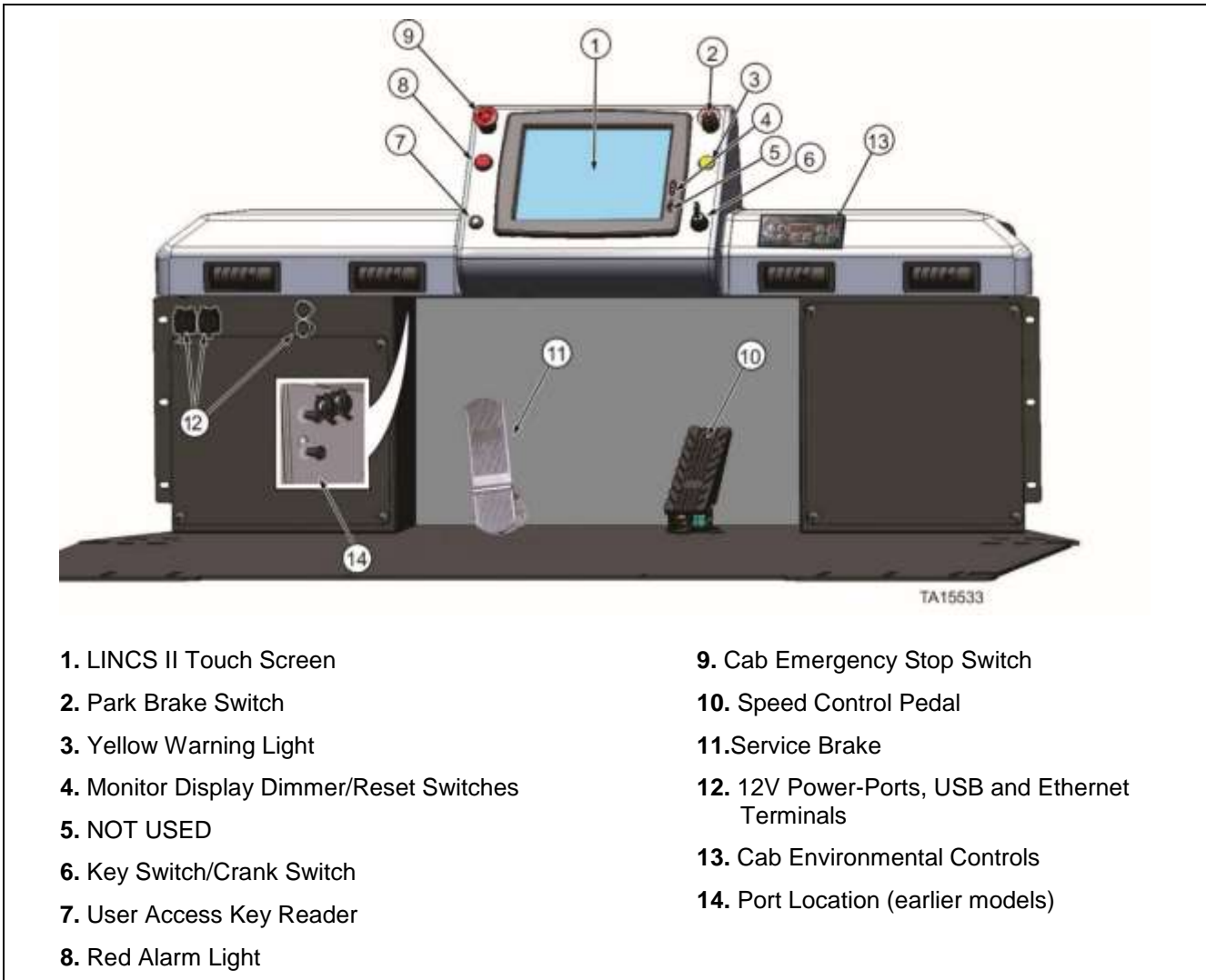

Figure 8. Cab control console

24V Maintenance Horn

Some machines may be equipped with a 24V electric maintenance horn that is not as loud as the air horn. The activation button is located above the key switch, on the operator console. It is typically used in a maintenance area. The horn is typically located under the cab, but may be located in the light bar mounting bracket on top of the Falling Object Protection Structure (FOPS).

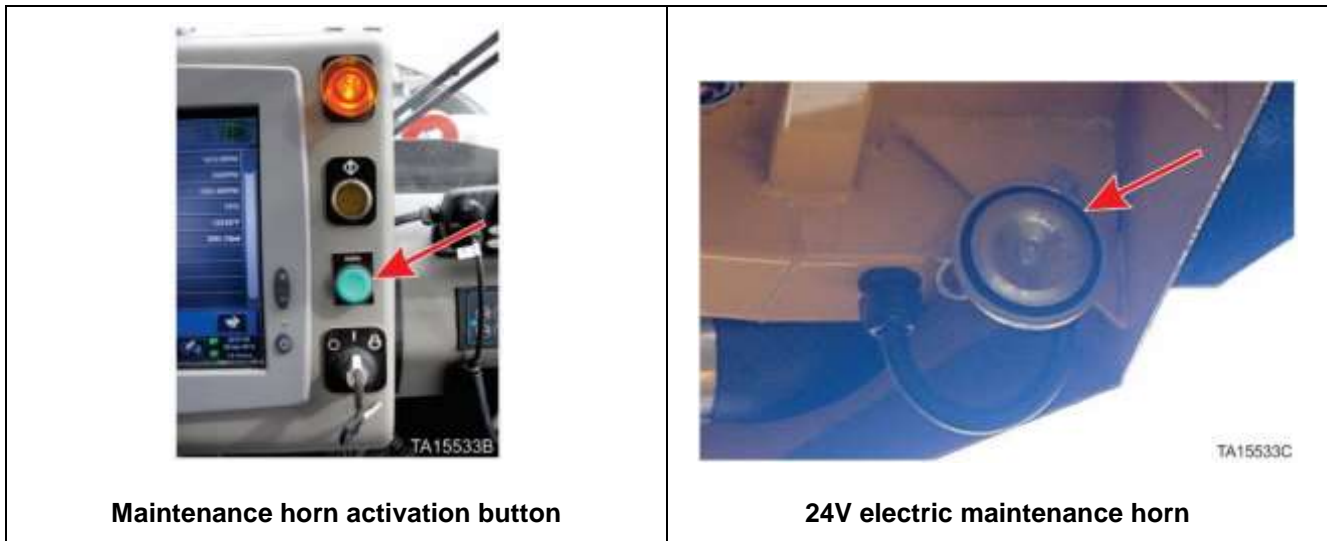

Figure 9. 24V maintenance horn

Park Brake Switch

(#2 on Illustration “Cab control console”)



The park brake switch is a push-pull type switch that has a built-in light that illuminates continuously when the brakes are set (also see NOTICE below). The park brakes are spring/air operated.

Pushing the park brake switch IN sets the park brakes by releasing air pressure from the brake actuator, and also inhibits propel.

- LINCS II will not allow the engine to crank unless the park brake switch is pressed IN.

Pulling the park brake switch OUT releases the park brakes by increasing air pressure to the brake actuator, and also enables propel.

- Hydraulics will not function unless the park brake switch is positioned OUT.

NOTICE

The park brake switch light illuminates off and on (flashes) if either of the following conditions occurs:

- If the park brake switch is pulled OUT, with the ladder in the up position, but air pressure is not enough to release the brakes, the light flashes until sufficient air pressure to release the brakes is achieved.
- If the park brake switch is pulled OUT, with the ladder in the DOWN position, a notice is posted on the touch screen, and the park brake switch flashes. Tractive power is inhibited until the ladder is raised to the full UP and LOCKED position. The park brake switch must be set again and re-released before the park brakes release.

WARNING

Crush hazards exist from leaving the cab without setting the park brakes, which could result in unplanned and uncontrolled movement of the machine. The operator should never leave the cab with the park brake released. Set the park brake before leaving the cab. Leaving the cab without setting the park brake could cause a crush hazard from unexpected machine movement, resulting in property damage, serious injury or death.

CAUTION

Struck by hazard exists if the park brake is set while the machine is in motion. This will stop the machine suddenly, possibly causing the operator to be thrown unexpectedly and rapidly against the seat belt or harness. Do not use the park brakes to stop the machine unless in an EMERGENCY situation. Use the service brake to stop the machine during normal operation. Using the park brake to stop the machine can cause the operator to be thrown forward rapidly against the seat belt or harness, resulting in injury.

Yellow Warning Light

(#3 on Illustration “Cab control console”)



The Yellow Warning light, Yellow Warning light and audible alarm indicate a problem that may not require immediate shut down of the engine but MUST BE INVESTIGATED and addressed immediately.

Monitor Display Dimmer/Reset Switch

(#4 on Illustration “Cab control console”)



The touch screen dimmer switch is a two-position momentary switch. Pressing the upper end (+) of the switch brightens the screen display and pressing the lower end (-) of the switch dims the screen display. Touching and holding both, resets the touch screen.

(#5) NOT USED

Key Switch/Crank Switch

(#6 on Illustration “Cab control console”)



The Key Switch/Crank Switch has three positions: OFF, ON and START.

The ON position turns on the electrical power to the instrument panel circuits, LINCS II computer system and electronic engine ECM, allowing fuel flow to the injectors.

The START position is a momentary position.

To start the engine:

- Set the park brakes.
- Move the directional switch to the center (neutral) position,
- Wait for the LINCS II system to boot up and the Park Brake switch light to illuminate.
- Turn the Key Switch/Crank Switch clockwise, to START. Once the engine starts release the switch. The switch returns to the ON position.

NOTICE

Cummins engines will NOT start immediately when the Key Switch/Crank Switch is turned to the START position.

To stop the engine under normal conditions:

- Stop the motion of the machine.
- Lower the bucket/blade to ground level (for safety reasons).
- Set the park brakes.
- Select LO engine idle.
- Turn the Key Switch/Crank Switch to the OFF position.
- Turning the Key Switch/Crank Switch to the OFF position activates the idle timer if needed.
- The idle timer allows the engine to run at low throttle for up to a TOTAL of five minutes, to cool the turbochargers.

NOTICE

If the machine has already been running at low throttle for the five previous minutes prior to turning the Crank switch OFF, the engine will shut down immediately. The engine must run a total of five minutes at low throttle before the engine will stop.

- The LINCS II computer system remains booted up.
- When the idle timer is activated, the touch screen provides an indication that the idle timer is operating.
- After five minutes, the engine fuel flow to the injectors stops, which stops the engine.

- The LINCOS II computer system remains booted up for an additional 15 seconds. During this 15-second interval, the Key Switch/Crank Switch can be switched back to the ON position and the LINCOS II computer system remains booted up. This function saves waiting the normal boot-up time to complete service work, data transmission, etc.
- If the Key Switch/Crank Switch is not switched back to the ON position during the 15-second interval, the LINCOS II computer system switches off and the power to the instrument panel is cut.

User Access Key and Reader

(#7 on Illustration “Cab control console”)



The User Access Key Reader is an access port which allows the LINCOS system to read an identification pendant (User Access Key). The User Access Key provides the LINCOS II system the ability to identify “access level” when it is touched to the reader. The level of LINCOS II access, personnel identity, and other information which affects the menu selection is programmed into the LINCOS II system. The system defaults to “operator” level upon startup (without use of the User Access Key).

Red Alarm Light

(#8 on Illustration “Cab control console”)



If a Red Alarm screen appears on the touch screen, the red indicator light illuminates and an audible alarm sounds when a monitored component falls outside normal operating parameters.

The alarm screen includes a brief text message to alert the operator to the nature of the problem. The operator can silence the audible alarm and remove the text message from the screen by pressing the acknowledge switch on the left joystick. The alarm screen will no longer appear but the light will continue to illuminate.

Cab Emergency Stop Switch

(#9 on Illustration “Cab control console”)



The Emergency Stop Switch mounted inside the cab, is a palm operated (push-in, pull-out), pushbutton type emergency stop switch. The Cab Emergency Stop Switch removes control from the computer, which kills the engine, disables the drive system, and shuts off the generator. When the switch is pressed, the park brakes will immediately set. When pushed, the switch locks. To unlock it, twist the switch knob in the direction of the arrows shown on its top. Ground-level emergency stop switches are also provided. Refer to Section 01-02 in the Service Manual for additional information and other locations.

⚠ CAUTION

Struck by hazard exists if using the emergency stop switch inside the cab to shut down the machine. This will immediately set the brakes and stop the machine suddenly, possibly causing the operator to be thrown unexpectedly and rapidly against the seat belt or harness. Use the emergency stop switch only in an emergency situation. Use the service brake to stop the machine during normal operation. Using the emergency stop switch to stop the machine can cause the operator to be thrown forward rapidly against the seat belt or harness, resulting in injury.

CAUTION

Use of the emergency stop buttons can cause engine turbo damage. Follow the proper engine shutdown process if there is not an emergency to stop the machine. Use the emergency stop switches only in an emergency. Immediate machine shutdown could result in damage to the engine turbochargers.

NOTICE

When the emergency shutdown circuit is actuated, the hydraulic reservoir automatic air release valve (Hydraulic reservoir air release valves) is tripped, releasing pressure in the hydraulic reservoir. This valve must be manually reset by pushing the reset button IN to the closed position.

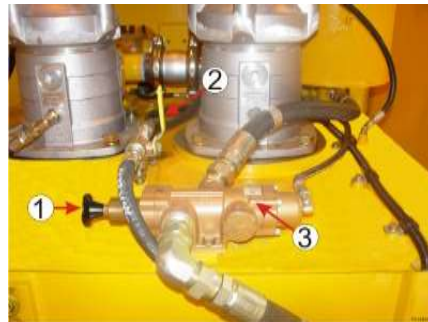

(mounted on top of hydraulic reservoir)

1) Reset Button, 2) Manual Relief Valve, 3) Automatic Air Release Valve

Figure 10. Hydraulic reservoir air release valves

Speed Control Pedal

(#10 on Illustration “Cab control console”)



The right pedal is the speed control pedal. The speed control pedal controls speed of the machine. The speed is proportional to the distance that the speed control is depressed. Conversely, as the speed control is released, the speed of the machine decreases and dynamic braking occurs, which brings the machine to a complete stop on flat ground. If stopping on a grade, the machine may have a tendency to creep. Should this occur, depress the Service Brake pedal with the left foot, and the machine will come to a complete stop.

NOTICE

The speed control pedal does not have to be released to change direction of travel (FORWARD or REVERSE). Refer to “Directional Control Switch”.

Service Brake Pedal

(#11 on Illustration “Cab control console”)



The left pedal controls the service brake.

Depressing the pedal activates the disc brakes on all four wheels.

The primary service brake function should be for EMERGENCY STOPS. However, when required, the brakes could be used to prevent machine movement or to hold the machine on a grade.

NOTICE

The service brake should **NOT** be routinely used to stop the machine during normal operation. The machine should be stopped by releasing the speed control pedal and utilizing the dynamic braking system. Use of the service brake to routinely stop the machine during material handling operations will result in accelerated wear of the disc pads and rotors.

12V Power-Ports, USB and Ethernet Terminals

(#12 & #14 on Illustration “Cab control console”)

Two 12V Power-Ports, are provided for connecting laptop computers used to troubleshoot various machine component systems or other auxiliary equipment. A USB Port and an Ethernet Port are provided to connect to and communicate with various computer controlled systems. Refer to “12V POWER-PORTS, USB AND ETHERNET CONNECTIONS” for locations.



1) Ethernet Connection, 2) USB Connection, 3) Power-Ports

Figure 11. 12V power-ports, USB and Ethernet connections

Climate Control Switches

(#13 on Illustration “Cab control console”)

Numbers in parentheses refer to “Climate control switches”. Refer to Vendor Literature for more information.

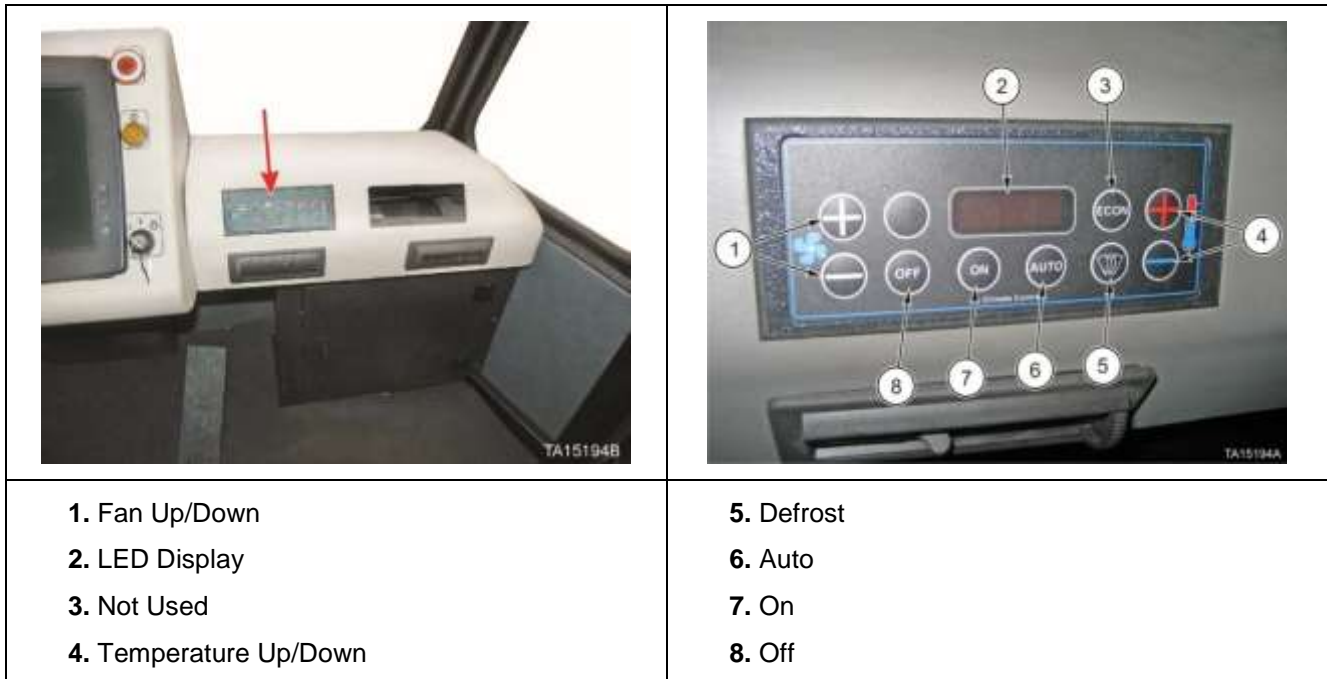

Figure 12. Climate control switches

FAN UP/DOWN (1) – Overrides the automatic fan speed control feature. Increments fan speed up or down in eleven (11) steps. The digital display indicates the fan speed setting as a percentage or “HI” when maximum fan speed is reached or “LO” when minimum fan speed is reached then returns to normal display five (5) seconds after either key is depressed. The set point fan speed is maintained until it is changed or if the AUTO key is depressed.

LED DISPLAY (2) – Displays error codes and other pertinent information.

NOT USED (3)

TEMPERATURE UP/DOWN (4) – Increments the set point temperature up or down. The system will control the electronic water valve and/or the A/C compressor clutch to hold the cab temperature as closely as possible to the set point temperature.

DEF (5) (Defrost icon) – Energizes the A/C system to allow for rapid de-humidification of the cab. The A/C will be enabled even if the set point temperature requires heat. A panel indicator light indicates when this mode is active.

AUTO (6) – Places the system in a fully automatic temperature control mode including fan speed. A panel indicator light indicates when this mode is active. The system will adjust the blower fan speed to the lowest setting necessary to maintain the cab temperature at the displayed set point temperature.

ON/OFF (7) (8) – Powers vehicle HVAC control system on or off. The LED numeric display is illuminated when the unit is turned on. The display will show the current set point temperature.

Special Key Functions

To display diagnostics, depress the ON key three (3) times. The digital display will then display any active fault codes. See Troubleshooting section of the vendor literature for fault code explanations.

To change the display from Fahrenheit to Celsius or back, depress the TEMPERATURE UP/DOWN (+, -) keys simultaneously.

Overhead Keypad



Figure 13. Overhead keypad

Alternate Height Switch (1)



(Refer to illustration “Overhead keypad”)

The Alternate Height Switch is a two position momentary pushbutton switch. A rotary transducer is provided on the loader that can be preset to stop the flow of hydraulic fluid to the bucket cylinders when the bucket reaches the predetermined height. The switch is set to stop the bucket at the same height during each lifting cycle when the loader is being used to load a fleet of vehicles of uniform height.

- When the switch is pressed, the alternate height limit function is enabled and the bucket will stop at the selected height each time. The LED will illuminate.
- To set the alternate height limit, hoist the bucket to the desired position and press and hold the Bucket Height Switch for a minimum of 2 seconds. If the lift arms are above 25° the height will be recorded in the loader’s computer and the lift arms will automatically stop at this height whether using the hoist detent switch or joystick to perform hoisting operations.
- The lift arms can be raised to full height without resetting the alternate height limit by

returning the right joystick to the neutral (center) position and then pulling back on the joystick. If the alternate height limit function is enabled while the lift arms are below 25°, the last programmed limit when hoisting, whether using the joystick or the hoist detent switch, becomes the alternate height limit.

- When the adjustable height limit function is enabled, after dumping the bucket, the operator must push the joystick forward or press the Return to Dig switch to lower and geometrically level the bucket.
- Pressing the switch a second time will turn OFF the adjustable height limit function and the LED will go OFF. When the adjustable height limit function is turned OFF, the preset limit switch is bypassed, and the bucket will rise to the maximum height attainable after the hoist joystick control is moved to the full back position or the hoist detent switch is pressed. The Alternate Height Switch should also be turned OFF when a fleet of vehicles of varying heights is loaded.

NOTICE

If the bucket is loaded to 120% of rated capacity hoisting action is inhibited, the yellow light illuminates, the audible alarm sounds, and the text screen indicating bucket overload appears on the computer monitor. The audible alarm can be silenced and the text message removed from the screen by touching a key on the touch screen keypad. However, the yellow light continues to illuminate.

Return to Dig/Auto Level Switch (2)



(Refer to illustration “Overhead keypad”)

The Auto Level Switch is a two-position momentary pushbutton switch. This switch enables or disables the auto-leveling feature of the bucket.

- When the switch is pressed, the auto-leveling feature is enabled. The left LED will illuminate.
- Pressing the switch a second time disables the auto-level feature and the LED goes out.
- If the auto-leveling feature is switched from disabled to enabled, and the button is pressed and held for a minimum of 2 seconds, while the lift arms are below 0°, the current angle of the bucket is recorded as the bucket angle to which to auto level.

Drive System Enable/Disable Switch (3)



(Refer to illustration “Overhead keypad”)

- Enables and disables the drive system.
- Drive may be enabled at low throttle for moving in out of the shop area.

Hazard Switch (4)



(Refer to illustration “Overhead keypad”)

The Hazard Switch is a two position momentary pushbutton switch.

- When the switch is pressed the yellow hazard lights on the front and rear of the loader are turned ON and will flash.
- The LED will illuminate.
- When the switch is pressed a second time the hazard lights are turned OFF and the LED will go out.

Throttle Switch (5)



(Refer to illustration “Overhead keypad”)

The Throttle Switch is a four-position momentary pushbutton switch.

- The Throttle Switch has three LED lights at the top of the switch.
- If the machine is equipped with a Cummins engine, when the engine is started the left LED will flash until the operating temperature has reached a point where the Cummins electronic control module will allow control of all engine functions by the LINC S II computer system. It will then stay on without flashing.
- If the machine is equipped with a Detroit Diesel engine the left LED will flash until the LINC S II computer system is in control of the engine functions and it will then stay on without flashing.
- When the LINC S II computer system gains control, the engine will run at LO throttle position (800 RPM).
- When the switch is pressed one time the engine will go to HI throttle. The left and right LEDs will illuminate without flashing. The center LED will go out.
- When the switch is pressed a second time the engine will go to L2 speed (1100 RPM) and both the center and left LEDs will illuminate without flashing.
- When the switch is pressed a fourth time the engine returns to LO throttle (800 RPM) and only the left LED will illuminate.
- Operate the loader only in HI throttle when performing material handling operations.

Front Windshield Wiper Switch (6)



(Refer to illustration “Overhead keypad”)

The Front Windshield Wiper Switch is a four position momentary pushbutton switch.

- When the switch is pressed the front windshield wiper will come on with intermittent or delayed operation. The left LED will illuminate.
- When the switch is pressed a second time, the front windshield wiper will come on at SLOW speed. The center LED will illuminate and the left LED will go out.
- When the switch is pressed a third time, the front windshield wiper will come on at HI speed. The right LED will illuminate and the center and left LEDs will go out.
- When the switch is pressed a fourth time, the front windshield wiper is turned OFF and all LEDs are turned OFF.

Rear Window Wiper Switch (7)



(Refer to illustration “Overhead keypad”)

The Rear Window Wiper Switch is a four position momentary pushbutton switch.

- When the switch is pressed the rear window wiper will come on at LOW speed. The left LED will illuminate.
- When the switch is pressed a second time, the rear window wiper will come on a MEDIUM speed. The center LED will illuminate and the left LED will go out.
- When the switch is pressed a third time, the rear window wiper will come on at HI speed. The right LED will illuminate and the center and left LEDs will go out.
- When the switch is pressed a fourth time, the rear window wiper is turned OFF and all LEDs are turned OFF.

Windshield and Rear Window Washer Switches (8 & 9)



(Refer to illustration “Overhead keypad”)

The Windshield and Rear Window Washer Switches are two position momentary switches.

- When the switch is pressed, the washer sprays a jet of window cleaning solvent on either the windshield or rear window (as selected) and the applicable wiper will come on to clean the glass.
- When the switch is released it returns to the OFF position. The solvent spray will stop and the wiper will stop.



Not Used (10)



(Refer to illustration “Overhead keypad”)

Some buttons are not assigned a function on some machine models. They do not have an icon.

Alternate Speed Switch (11)



(Refer to illustration “Overhead keypad”)

The Alternate Speed Switch is a two position momentary switch.

- When the Alternate Speed Switch is pressed once, the loader’s top speed is limited to a preset speed limit. The LED light will illuminate.
- Refer to “USER PREFERENCES” screen settings in Section “ELECTRICAL SYSTEMS”, VEHICLE CONTROL SYSTEM (LINCS) in the Service Manual.
- When the switch is pressed a second time, the Alternate Speed function is turned OFF and the loader’s top speed is returned to normal. The LED light will go out.

Auto Lube Switch (12)



(Refer to illustration “Overhead keypad”)

The AUTO LUBE Switch is a two-position momentary switch that starts the automatic lubrication pump. The engine must be running for the AUTO LUBE Switch to operate.

Drive disabled:

- Pressing the AUTO LUBE Switch activates the lubrication pump. The LED illuminates.
- Releasing the switch turns the lubrication pump OFF. LED goes OFF.

Drive enabled:

- Pressing the AUTO LUBE Switch activates the lubrication pump. The pump cycles through the set cycle time. The LED illuminates until the pump turns OFF.
- Should there be a problem with the lubrication system, either a Yellow Warning Light or a Red Alarm Light, and an audible alarm comes on and a message appears on the computer screen.

NOTICE

Two other switches labeled Lubrication Cycle are also provided. One is located in the Isolation and Control Switch Box mounted at the left rear of the machine. The other is mounted inside the front frame, above the auto lube pump. These switches perform the same function as the Lube Switch on the Overhead Switch Panel.

CAUTION

Always ensure the automatic lubrication system is operating properly during operation of the machine. Check auto lube operation frequently during operation. Never, under any circumstances, operate the machine with the automatic lubrication system inoperable. Serious component damage will occur.

Auxiliary Torque Switch (13)



(Refer to illustration “Overhead keypad”)

- The Auxiliary Torque Switch is a pushbutton switch and has one LED.
- The switch is programmable with the LINCS II computer system.
- Refer to “USER PREFERENCES” screen settings in Section “ELECTRICAL SYSTEMS”, VEHICLE CONTROL SYSTEM (LINCS) in the Service Manual.

Cruise Switch (14)



(Refer to illustration “Overhead keypad”)

The Cruise Switch is a three state momentary pushbutton switch and has two LEDs.

- Cruise control allows the machine to travel at the speed commanded by the speed control pedal at time cruise control is activated. Cruise control speed can be increased or decreased by pushing the joystick forward to increase or pulling the joystick back to decrease speed. The following actions will disable cruise (once it is set).
- Pressing the Cruise Control switch again.
- Actuating the Service brakes.
- Actuating the Park brake.
- Placing the Direction switch to Reverse or Neutral.
- Depressing the Speed control pedal.
- Machine speed <1 mph.

Beacon Light Switch (15)



(Refer to illustration “Overhead keypad”)

The Beacon Light Switch is a two-position momentary pushbutton switch that operates the flashing beacon mounted on top of the operator’s cab.

- When the switch is pressed once, the beacon light is turned ON.
- When the switch is pressed a second time, the beacon light is turned OFF.

NOTICE

Turn the beacon light on **ANYTIME** the loader is operating.

Pole Work Lights Switch (16)

Cab Light Bar Lights Switch (16)

Rear Cowl Lights Switch (16)



(Refer to illustration “Overhead keypad”)

The Lights Switch is a four-position momentary pushbutton switch.

The machine is equipped with 24-VDC, 35-watt, lights that are mounted on each side of the cab, on the light bar (Cab Light Bar Lights), on poles below the light bar (Work Lights) and on each side of the rear of the machine, above the radiator (Rear Cowl Lights-facing the rear of the machine). The lights are provided for nighttime material handling operations and for travel.

Each press of the button, within 2 seconds, turns ON or OFF a different set of lights as described below.

| Times Button is Pressed within 2 seconds* | Pole work lights and (1 ST LED on switch) | Cab light bar lights and (2 ND LED on switch) | Rear cowl lights and (3 RD LED on switch) |
|---|--|--|--|
| Lights and indicator LED illuminated | | | |
| 1 | YES | YES | YES |
| 2 | YES | NO | YES |
| 3 | YES | NO | NO |
| 4 | NO | NO | NO |
| *Pressing the button after 2 seconds turns all lights OFF. | | | |

Figure 14. Light switch operation

NOTICE

Turning ON any of these lights also changes the screens being displayed on the touch screen. The screens slightly change color to accommodate for the expected lower ambient light encountered in a darker environment. The red and yellow lights on the console dim also.



Front light locations (cab light bar lights)
(Mounted each side of cab) (light type may vary)

- 1, 2, 3, 5) Front lights
- 4) Turn signals

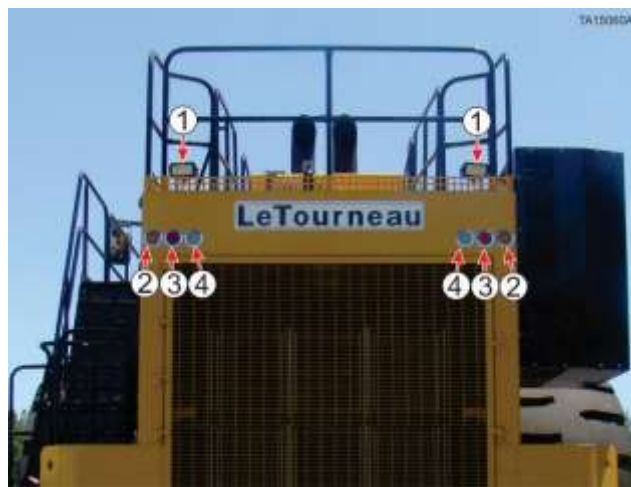

1) Rear cowl lights, 2) Turn signal lights-yellow, 3) Stop, tail lights-red, 4) Back-up lights-white

Rear Light Locations

Figure 15. Front and rear light locations

⚠ WARNING

Electrical shock and crush hazards exist if lights are serviced while the machine electrical system is energized or not locked out and unexpected machine movement occurs. Always de-energize and lock out the machine electrical system before servicing the lights. Electrical shock is possible, resulting in serious injury or death. If the machine is started up while the lights are being serviced, a crush hazard is possible from unexpected machine movement, resulting in serious injury or death.

Proximity Detection System

If the machine is equipped with a proximity detection system, the operator must be trained in its use before operating the machine. Various settings, such as warning distance, can be set to various distances, depending on local rules and regulation requirements.

The system consists of a panel in the cab for visual and audible alarms and an external receiver/transmitter. The system detects other vehicles (with installed systems) and provides visual or audible warnings when the machines come within the set detection distance.

Follow the manufacturer recommendations for operation and maintenance.



Figure 16. Typical proximity detection system components

This Page Intentionally Left Blank

Cab Interior Lights (Dome)

Two dome lights are flush-mounted in the cab ceiling. They have LEDs for lighting and are controlled by a switch on each access door, and a manual switch mounted on the overhead console. Opening either access door actuates the lights.

Cab Interior Lights Manual Switch (Dome)

The Cab Interior Lights Switch is a two position rocker switch mounted to the right of the Overhead Switch Panel.

- Moving the switch up turns the cab interior lights ON.
- Moving the switch down turns the cab interior lights OFF.



Figure 17. Cab dome light switch

This Page Intentionally Left Blank

Operator's Cab

The Operator's Cab has doors on each side to allow entry or exit as is convenient for the operator or should egress be required from either side due to an emergency situation. A catwalk extends around the front of the cab to allow the operator to walk around the front of the cab. Refer to "Operator's cab – left side view through cab to right side", "Operator's cab – right side" and "Operator's cab – left side door".



Figure 18. Operator's cab – left side view through cab to right side



Figure 19. Operator's cab – right side

NOTICE

It is recommended that the stairs and walkway on the left side of the machine be used for normal entry and exit.

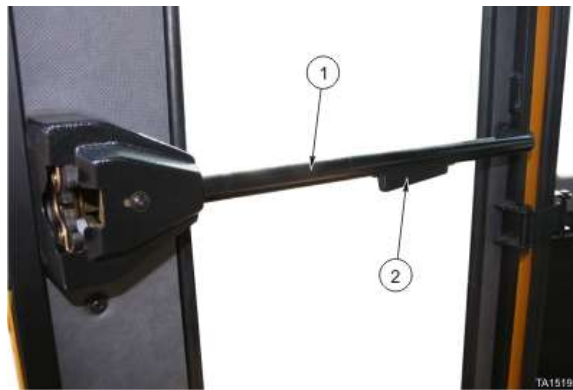

Figure 20. Operator's cab – left side door

 **WARNING**

Fall hazard or struck by foreign objects hazard is possible while climbing the hydraulic reservoir ladder near the KLENZ™ air filtration system if the system emits a loud “boom” and ejects dust from the hopper. Turn the KLENZ™ Enable Switch OFF before climbing the ladder. The loud “boom” could cause a person on the ladder to be startled and lose their grip, resulting in a fall. **DO NOT** climb the hydraulic reservoir ladder or stand near the bottom of the ladder of an operational machine unless the KLENZ™ Enable Switch is in the OFF position, except in an emergency situation. Serious injury from a fall or being struck by foreign objects is possible, resulting in serious injury or death.

A grab bar for pulling the doors closed or pushing them open is provided across the inside of each door. The bars have an integral squeeze-to-open handle. Refer to “Grab bar” and “Squeeze-handle to-open”.



1) Bar, 2) Squeeze-To-Open Handle

Figure 21. Grab bar



Figure 22. Squeeze-handle to-open door

Ample glass is provided in the windshield and wing panels to provide the operator a panoramic view of the work location. Refer to “Panoramic view from cab”.



Figure 23. Panoramic view from cab

This Page Intentionally Left Blank

Operator's Seat

The machine is equipped with a fully adjustable air-suspension operator's seat. The joystick controls for hoist and bucket or blade (applicable) and steering are mounted on either side of the seat. The operation of the joystick controls is provided in LEFT-HAND JOYSTICK CONTROL and RIGHT-HAND JOYSTICK CONTROL, located within this section of the Service Manual.

WARNING

Crush hazards exist if the operator seat is improperly adjusted which causes loss of machine control during operation. Adjust the seat for proper access to all controls and fasten seat belt or harness before operating the machine. Loss of machine control could cause a crush hazard resulting in serious injury or death to personnel in the operating area.

Automatic and Manual Seat Adjustments and Controls

(Refer to “Operator’s seat”)

The operator’s seat has the following adjustments:

(1) WEIGHT ADJUSTMENT - The seat should be adjusted for the operator's weight by briefly pulling the actuator lever of the automatic weight and height adjuster (arrow) with the vehicle at a standstill and the operator sitting on the seat. The operator must sit completely still during adjustment. The setting for the operator's weight must be checked and adjusted as necessary before the machine is driven.

(2) HEIGHT ADJUSTMENT - The seat height can be pneumatically and is infinitely adjustable. The seat height can be altered by pulling or pressing the actuator lever fully out or in (arrow). If the adjustment reaches the top or bottom end stop, the height is adjusted automatically, to guarantee a minimum of spring travel. To avoid damage, do not operate the compressor more than one minute.

(3) SEAT PAN ANGLE ADJUSTMENT - The angle of the seat pan can be individually adjusted. To adjust the angle of the seat pan, lift the left-hand handle (arrow). By exerting pressure on or off, the seat pan can be moved to the desired position.

(4) SEAT DEPTH ADJUSTMENT - The depth of the seat pan can be individually adjusted. To adjust the depth of the seat cushion, lift the right-hand handle (arrow). By moving the seat cushion backwards and forwards, the desired seating position can be reached.

(5) ABSORBER - The absorber adjustment setting of the seat can be varied to suit the on- and off-road driving conditions. The cushioning effect can be individually adjusted for this purpose. Turn the lever to the desired position and release for either hard or soft.

(6) ARMREST ADJUSTMENT - The inclination of the armrests can be modified by turning the adjustment knob (arrow).

(7) ARMREST HEIGHT ADJUSTMENT - The armrests can be folded up if desired and height individually adjusted. To adjust the armrests for height, separate the round cap (arrow) from the cover, loosen the hexagon nut (13mm) and adjust the armrest to the desired height and tighten the nut again.

(8) HEADREST - The headrest can be individually adjusted for height by pulling it upward over the various increments up to the end stop. By pushing forward or backward, the angle of the headrest can be adjusted individually. To remove the headrest, pull it over the end stop.

(9) LUMBAR SUPPORT - The curve of the backrest cushion can be individually adjusted by turning the knob on the back of the seat.

(10) BACKREST ADJUSTMENT - The backrest is adjusted using the locking lever (arrow). The locking lever must latch into the desired position. It should not be possible to move the backrest into another position when it is locked.

(11) FORE/AFT ISOLATOR - Under certain driving conditions, it is useful to activate the fore/aft isolator. This means that shock impacts in the driving direction can be better absorbed by the seat. Position 1 = fore/aft isolator on, Position 2 = fore/aft isolator off.

(12) FORE/AFT ADJUSTMENT - The fore/aft adjustment is released by lifting the locking lever. The locking lever must latch into the desired position. It should not be possible to move the seat into another position when it is locked.

OPERATOR ENTRY AND EXIT - The seat will not swivel. Either armrest will pivot upward to aid in operator entry and exit.

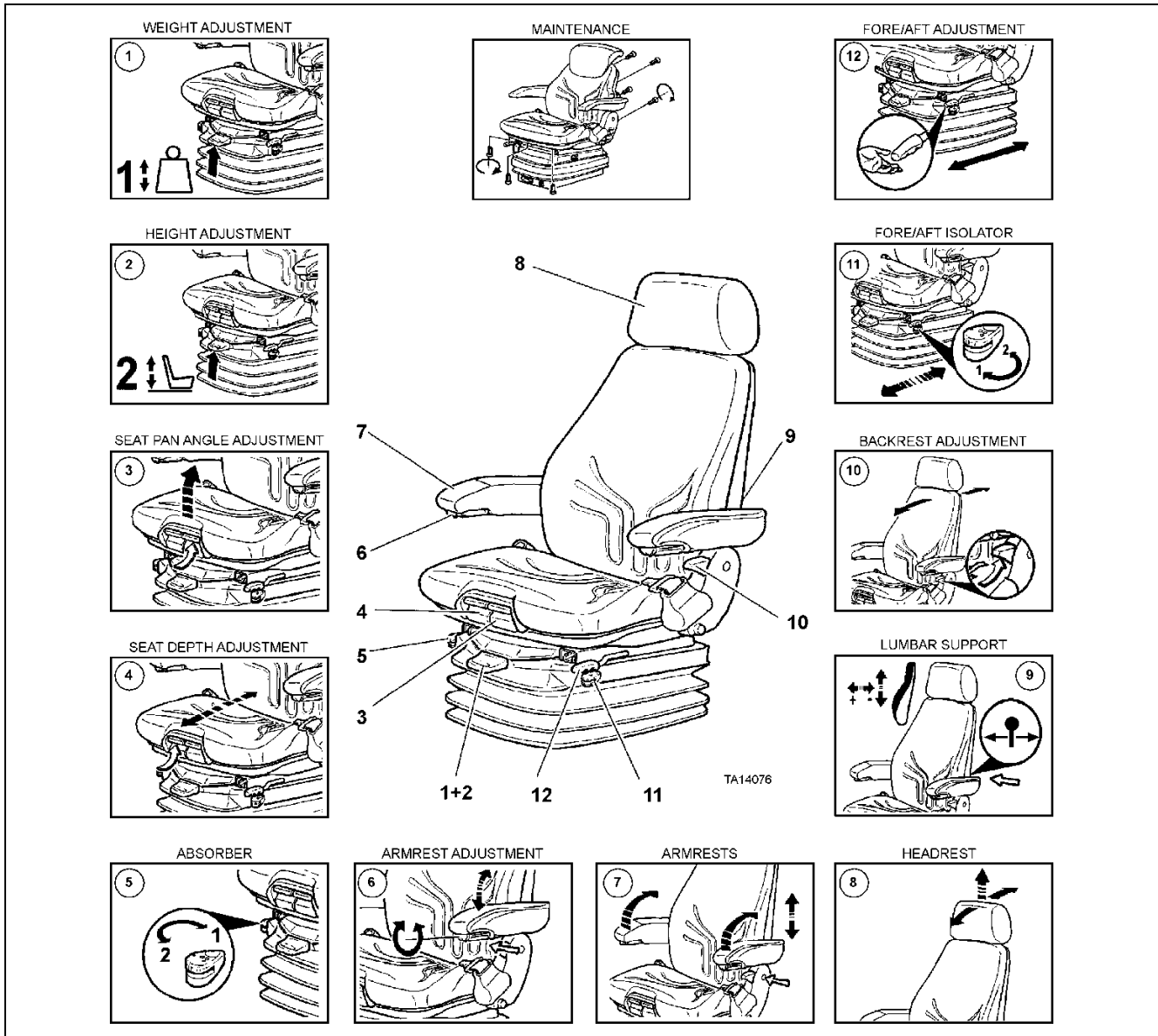

Figure 24. Operator's seat (typical)

Maintenance

Dirt can impair the function of the seat. It is essential to make sure the seat is kept clean. Upholstery can be quickly and simply removed from the seat frame for easy cleaning or replacement. During cleaning, the upholstery should not be soaked through. Use a commercially available, standard upholstery cleaning agent when cleaning the seat. Test first for compatibility on a small, concealed area and follow manufacturer recommendations.

CAUTION

Struck-by or pinch point hazards exist if the operator seat backrest upholstery is removed for cleaning or maintenance and the backrest frame is not supported. The backrest frame must be supported, for example held in place, before the backrest adjuster is operated. If this is not done, there is a danger that the backrest frame may jerk forward and cause a struck-by or pinching injury.

This Page Intentionally Left Blank

Seat Belt Operation and Adjustment

The machine is equipped with an adjustable 4 point seat belt harness to accommodate various requirements of operators. The seat belts are mounted to the operator's seat.

WARNING

Crush hazards exist if the operator seat belt or harness is improperly adjusted or improperly maintained. Improper adjustment or maintenance of the seat belt or harness could result in loss of machine control during operation, resulting in a crush hazard. Adjust the seat and seat belt or harness for proper access to all controls and fasten seat belt or harness before operating the machine. Always check the condition of the operator seat belts and mounting hardware before operating the machine. Failure to do so could result in serious injury. Loss of machine control could cause a crush hazard resulting in serious injury or death to personnel in the operating area.

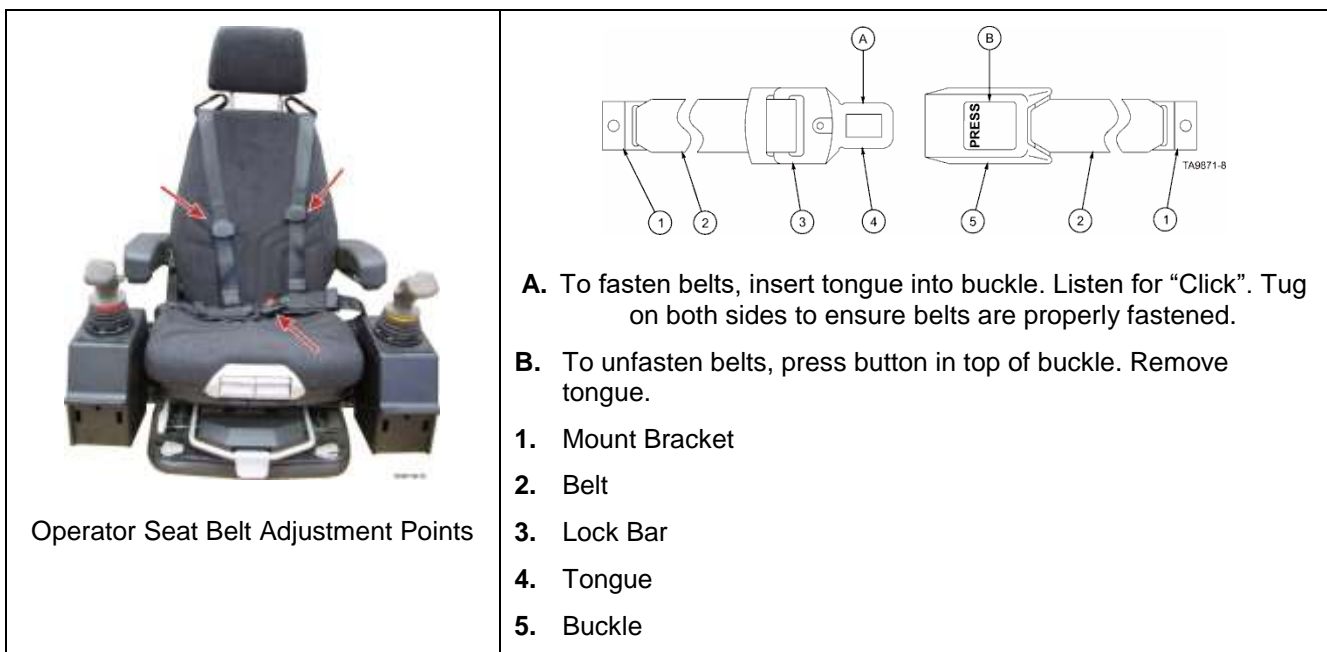

Figure 25. Seat belt components and fastening/unfastening procedures (typical)

Fastening and Unfastening the Belt

Fastening the Belt

Insert the tongue into the buckle. Listen for the “click” that indicates the belts are fastened. Tug on the belt to be sure it is securely fastened. Adjust the vertical straps until the entire seat harness is properly adjusted.

Unfastening the Belt

Press the release button in the buckle and pull the tongue from the buckle.

Adjustments

The belt should be tight but comfortable. The vertical straps and horizontal belt have adjustment points that can be tightened or loosened.

Lengthening the Belt

With the belt unfastened, move the lock bar slide toward the buckle.

Pull on the buckle until the slack is removed from the outer belt loop.

Readjust the belt if it does not fit snugly.

To Shortening the Belt

With the belt fastened, pull on the outer loop to tighten the belt.

Inspection

- a. Inspect for worn or frayed webbing.
- b. Check for worn or damaged buckle or lock bar. Replace the entire assembly if worn or damaged.
- c. Inspect the belt and harness mounting hardware. Replace any damaged or worn hardware. Keep the mounting bolts tight.

Service Switches

Isolation and Control Switches Assembly

The Isolation and Service Switches Assembly, located on the left side, at the rear of the machine, contains components useful to maintain safety during machine maintenance.

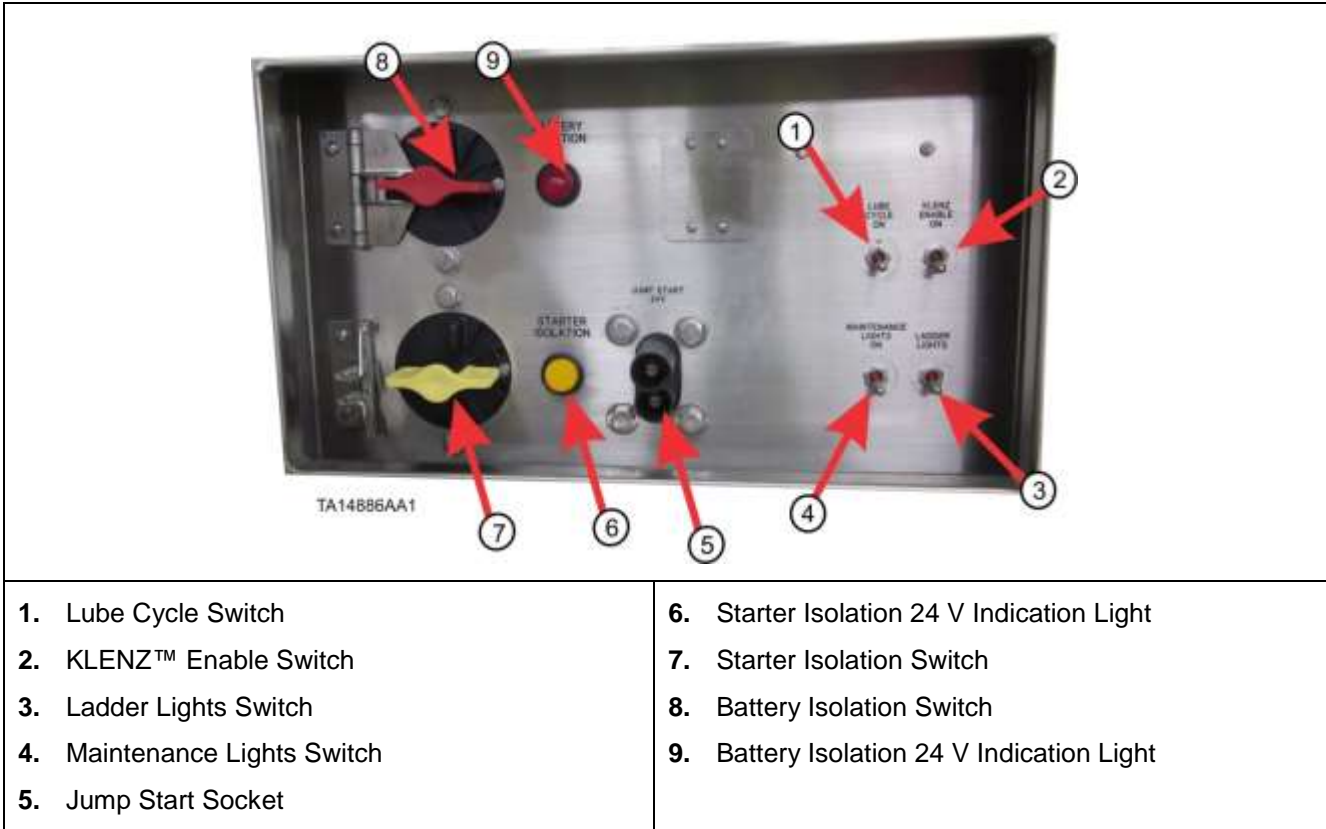

Figure 26. Isolation and control switches assembly

Auto Lube Switch

Because the automatic lubrication system is hydraulically powered, the engine must be running for the AUTO LUBE Switch to actuate the AUTO LUBE pump motor. When the drive is not enabled and any AUTO LUBE Switch is pressed to the ON position, the automatic lubrication system will run as long as the button is held down. When the drive is enabled and any AUTO LUBE Switch is pressed to the ON position, the automatic lubrication system will cycle once. The switch on the keypad on the overhead panel has a built in led that illuminates during any AUTO LUBE system cycle/actuation (manual or timed).

There are three AUTO LUBE Switches. They are located:

- Inside the Isolation and Control Switch Box on the left rear of the machine.
- On the overhead keypad in the operator's cab.
- Inside the front frame, above the grease reservoir on the frame wall.

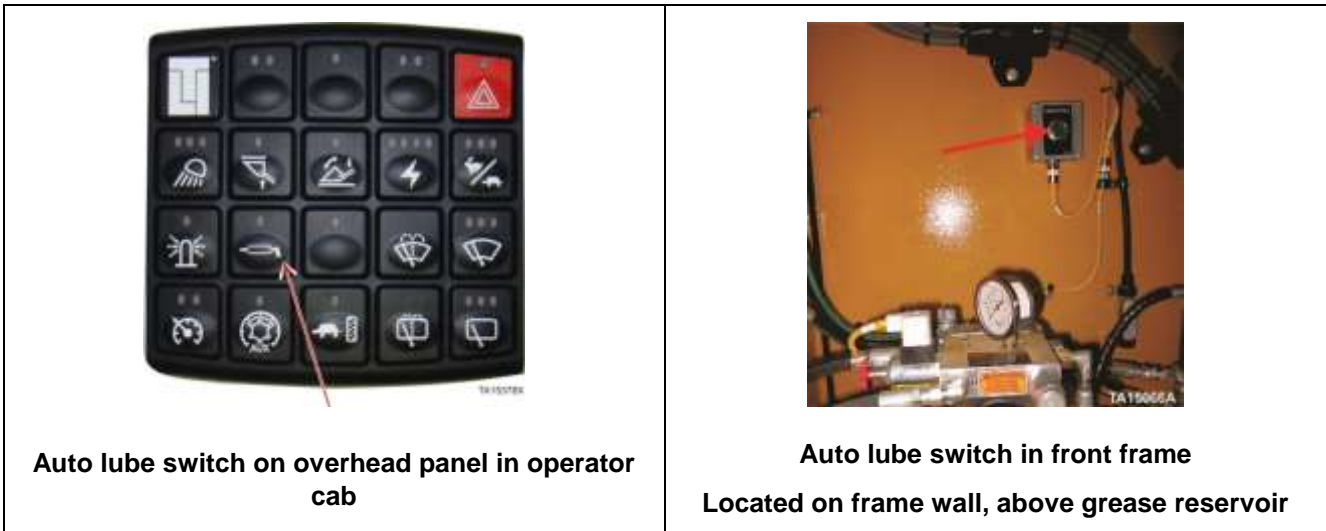

Figure 27. Auto lube switch locations (1 of 2)



Figure 28. Auto lube switch locations (2 of 2)

KLENZ™ Enable Switch



Figure 29. KLENZ enable switch

The KLENZ™ Enable Switch, located inside the Isolation and Control Switches Assembly, is a two-position maintained toggle switch. The Switch turns OFF the purge cycle of the Komatsu Cartridge Filtration System (KLENZ™ system). Unless turned OFF, the purge cycle continues until there is no longer adequate pressure in the air system. When the purge occurs, the system emits a loud “boom” and dirt is blown from the hopper. The noise can be startling and dirt blowing from the hopper can present a hazard to persons climbing the ladder adjacent to the KLENZ™ system or standing under the hopper.

WARNING

Hearing damage or eye injury hazard exists if the KLENZ™ Enable Switch is not turned to the OFF position before performing any service work to the machine. Bleed air pressure to zero psig before performing any service or repair work to the KLENZ™ system or other components powered by the compressed air system. Failure to bleed the air pressure to zero in the compressed air system can cause hearing damage or eye injury from a sonic blast within the KLENZ system resulting in serious injury.

NOTICE

When the KLENZ™ Enable Switch is turned OFF, a notice screen, with a text message appears on the LINCS II touch screen in the operator’s cab. BE SURE to turn the KLENZ™ Enable Switch to the ON position and close the manual air release valve before returning the machine to service.

Ladder Lights Switch

(Refer to illustration “Isolation and Control Switches Assembly”).

The machine is equipped with 24-VDC lights for illuminating the access ladder, staircase and work service areas. The ladder and staircase lights are mounted on top of the rear frame and on top of the operator’s cab. Two, 2-position switches are provided to turn the lights on and off. The upper switch is mounted behind the cab. The lower switch is located on the Control Switch Box. The switches are labeled “Ladder Lights”.



Figure 30. Ladder light switches

Maintenance Lights Switch



Figure 31. Maintenance lights switch

The Maintenance Lights Switch, located inside the Isolation and Control Switches Assembly box, is a two-position maintained toggle switch that controls the 24V DC service maintenance lights mounted on each side of the radiator, mid-engine, near the generator and in the front frame. The Key Switch/Crank Switch on the operator's console does not have to be in the ON position to operate the lights, but the Battery Isolation Switch must be in the ON position.

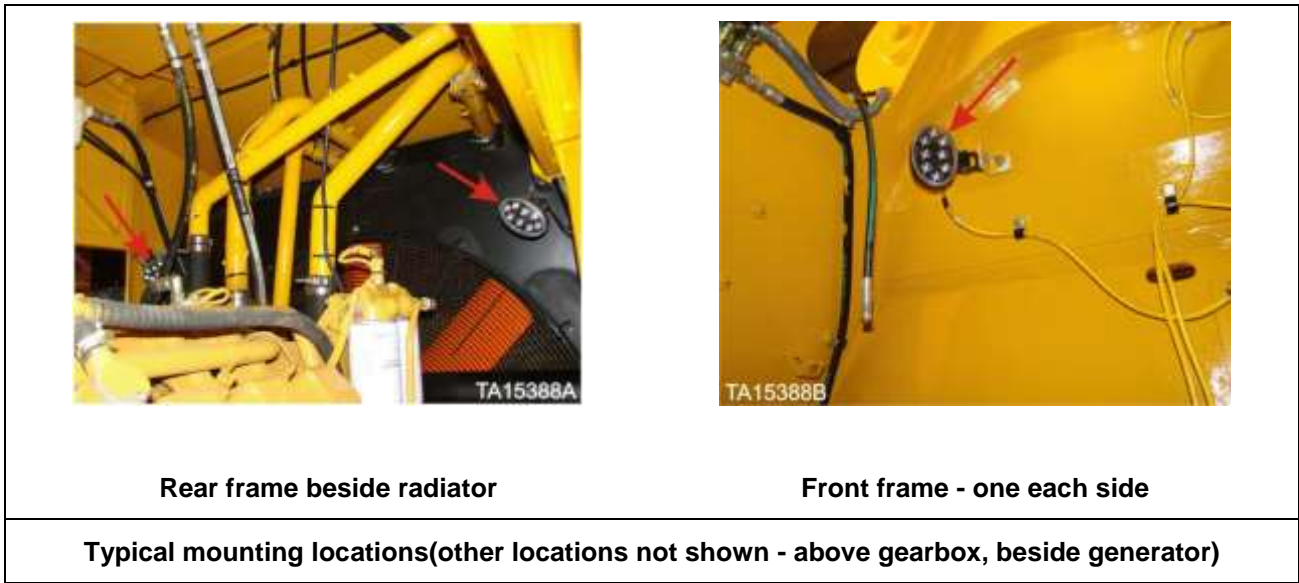

Rear frame beside radiator

Front frame - one each side

Typical mounting locations(other locations not shown - above gearbox, beside generator)

Figure 32. Maintenance lights (maintenance work lights)

Jump Start Socket



Figure 33. Jump start socket

The battery jump start socket is located inside the Isolation and Control Switches Assembly box. It is possible to damage the electronic controls of the machine and engine if jumper cables are connected improperly or arcing occurs. Therefore, Komatsu recommends that the machine only be jump started or used to jumpstart another vehicle with the optional jumpstart socket.

⚠ WARNING

Battery posts, terminals and related accessories contain lead and lead components, chemicals known to the State of California to cause cancer and birth defects or other reproductive harm. Do not handle lead components without proper personal protective equipment (PPE).

Starter Isolator Indication Light and Starter Isolation Switch

For maintenance where 24 volts is required (for 24 volt circuit testing or for repairs at night) the YELLOW Starter Isolation Switch can be turned to the OFF position. When the YELLOW Starter Isolation Switch is turned OFF, there will be 24 volt power available for all machine functions, except engine cranking. The switch can be locked in the OFF position if desired. When the Starter Isolation Switch is turned to the ON position, the engine cranking function is enabled.

The YELLOW light is illuminated when the engine cranking function is enabled.

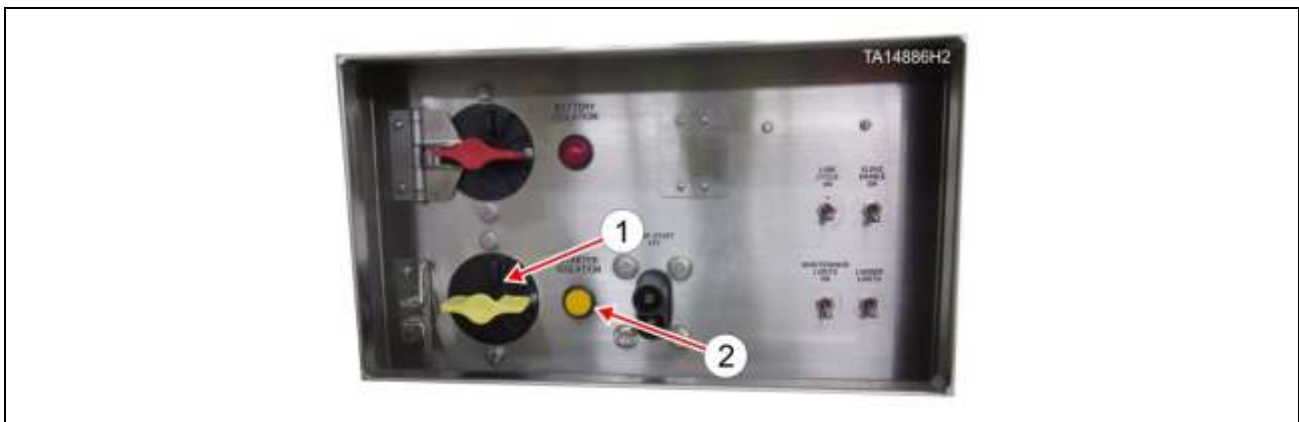

1) Starter isolation switch, 2) Starter isolator indication light

Figure 34. Starter isolator indication light and starter isolation switch

Battery Isolation Switch and Battery Isolator Indication Light

If necessary to leave the machine unattended or if necessary to eliminate all electrical energy sources, turn the RED Battery Isolation Switch to the OFF position. This switch can be locked in the OFF position if desired. When the Battery Isolation Switch is turned to the ON position, the 24V system is enabled.

The RED light is illuminated when the Battery Isolation switch is in the ON position, (24V battery power is enabled). The machine engine cannot be started unless the 24V system is enabled.

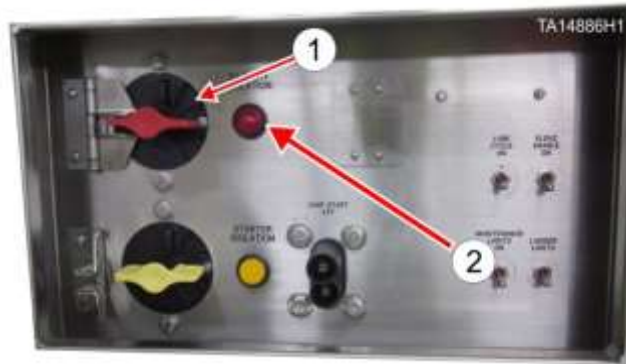

1) Battery isolation switch, 2) Battery isolator indication light

Figure 35. Battery isolator indication light and battery isolation switch



1. Isolation and Control Switch Box Assembly (Typical Location).
2. Auto Lube Switch (Inside Front Frame – Above Grease Reservoir)
3. Upper Ladder Light Switch-Beside Cab

Figure 36. Service switch locations

Central Service System (Optional)

(Refer to illustration “Central Service System (optional)”)

The optional central service system is housed inside a protective box and mounted at the left rear of the machine. The central service system provides quick-coupling connections for refilling the fuel reservoir, engine crankcase, hydraulic reservoir, and engine coolant. Different quick couplers are provided for each component to ensure accuracy in filling.

NOTICE

When using the Central Service system, be sure to relieve pressure in the hydraulic reservoir and in the radiator by opening the manual air release valve provided for each component before attaching a hose to the quick couplings (refer to illustration “Hydraulic reservoir air release valve”). Be sure to allow sufficient time for each reservoir to de-pressurize. The filling process will be slow and the reservoir relief valves will open if pressure is not relieved before filling begins.



Figure 37. Central service system (optional)



(mounted on top of hydraulic reservoir)

1. Reset Button
2. Manual Relief Valve (handle in open position (reservoir de-pressurized)).
3. Automatic Air Release Valve



Right side view of # 2 at left - handle in closed position (reservoir pressurized)

Figure 38. Hydraulic reservoir air release valves



1) Radiator Cap, 2) Manual Pressure Relief Valve, 3) Sight Glass

Figure 39. Radiator reservoir cap and manual de-pressurizing valve

Component Heater Connections (Optional)

220-volt receptacles component heater connections, located on the rear frame, inside the pivot area, on the left side of the machine, are optionally provided for connecting the optional hydraulic reservoir, battery, grease reservoir, and engine coolant and oil heaters. Connections are accessible from ground level.



1. Receptacle #1: Hydraulic Reservoir, Battery Heater, Grease Reservoir
2. Receptacle #2: Engine: Oil Preheater, Coolant Preheater Connections

Figure 40. Component heater connections

This Page Intentionally Left Blank

Mounting and Dismounting the Machine

These guidelines should be followed when mounting and dismounting the machine:

WARNING

Crush hazards exist if attempting to transport personnel on the machine. There are no provisions on the Komatsu built wheel loader to accommodate the transportation of any persons other than the operator alone, unless a training seat in the cab is optionally provided. Ladders and catwalks attached to the machine are designed for servicing of the machine while the machine is stopped only. They are NOT designed for transporting riders at any time. Do not transport personnel or allow riders on the machine. A crush hazard is present while riding on any location of the machine other than the cab Operator's seat or training seat (if so equipped), which could result in serious injury or death.

- a. Always use "three-point support" with the machine, and face the ladder while you enter or leave it. "Three point support" means that three out of four arms and legs are in contact with the machine at all times during mount and dismount.

CAUTION

Fall hazards and slipping hazards exist if ground conditions are not checked before dismounting the machine. Before dismounting, ensure the ground conditions are such that slipping or falling does not occur when stepping off the ladder. Always ensure firm ground before releasing the ladder. Slipping and falling could result in serious injury.



- b. Clean shoes and wipe hands before attempting to climb on the machine.
- c. Look for icy conditions that could make use of a ladder or stairway treacherous. Follow all local work rules used during icy conditions.
- d. Use handholds, ladders, or steps (as provided) when mounting and dismounting.
- e. NEVER attempt to mount or dismount a moving machine.
- f. NEVER jump off the machine.
- g. NEVER try to climb on or off the machine when carrying tools or supplies. Use a hand line to pull equipment up onto the platform.
- h. Observe proper shutdown procedures before dismounting.

Ladder Mounted on Hydraulic Reservoir

A ladder is mounted on the hydraulic reservoir. When using this ladder, refer to instructions in "Mounting and Dismounting the Machine" as previously explained in above text.

This Page Intentionally Left Blank

Powered Access Ladder

"Power Step Model RL1001 & RL1002"

Some P&H wheel loaders are optionally equipped with a powered access "Power Step Model RL1001" ladder mounted on the left rear of the rear frame.

Safe operation of the ladder depends on adherence to the safety warnings and cautions, and all safety rules required in the user's area of operation. Periodic inspection and service must also be performed to the ladder to ensure safe and trouble-free operation.

WARNING

Struck by or Crush hazards exist if personnel are in the travel area of the ladder when it is being lowered or raised. The ladder lowers and raises rapidly when engaged. Before lowering or raising the ladder, make sure all personnel are clear of the area. Being struck by the ladder or thrown off the machine could result in serious injury or death.

WARNING

Struck by or Crush hazards exist if personnel are in the travel area of the ladder when it is being lowered by using the back-up bleed down valve. When lowering the ladder, be certain all personnel are a safe distance from the ladder. Lowering the ladder without power by activating the "Back-up Bleed Down Valve" causes the ladder to RAPIDLY lower NON-STOP until reaching ground level. Releasing the "Back-up bleed Down Valve" knob or cable will NOT stop the ladders' rapid decent to ground level. Being struck or crushed by the ladder could result in serious injury or death.

WARNING

Fall hazard or Crush hazards exist if personnel rides the ladder up or down. Never ride the ladder up or down when it is being activated. Being struck by or crushed by the ladder could result in serious injury or death.

CAUTION

Component damage can result from attempting to ride the ladder up or down during operation. Do not ride the ladder up or down. Riding the ladder will void the manufacturer's warranty and could result in component damage.

WARNING

Struck by or Crush hazards exist if the ladder is not de-energized prior to performing maintenance work on it. Place the ladder in the "DOWN" position and use Battery Isolation Switch to de-energize the ladder prior to performing any service operations to the ladder. Failure to de-energize the ladder prior to working on it could cause personnel to be struck by or crushed by the ladder, resulting in serious injury or death.

⚠ WARNING

Crush hazards exist if the park brake is not set before operating the ladder. Before raising or lowering the ladder, set the machine park brake. Uncontrolled machine movement could cause a hazardous condition when trying to enter or exit the ladder, which could result in serious injury or death.

⚠ WARNING

Fall hazard exists due to uncontrolled ladder movement if it is not placed in the full down position before entering or exiting the ladder. Place the ladder in the full DOWN position before entering or exiting the ladder. Serious injury is possible if the ladder is not in the full DOWN and LOCKED position before entering or exiting the machine.

⚠ WARNING

Fall hazard or crush hazards exists when operating the ladder or using it to enter or exit the machine. To avoid personal injury and component damage it is essential that all personnel using the ladder be familiar with its operation and all indicators and alarms. Falls and crush hazards are possible if personnel are not familiar with the ladder operation before using it, which could result in serious injury.

Normal Operation

Two switches are provided to raise and lower the ladder. One switch operates the ladder at ground level, the other operates the ladder from an elevated level. A ground-level switch is mounted to the left of the ladder. The elevated-level switch is mounted at the ladder dismount area. Both locations have access to the mechanical safety latch that must be disengaged before raising or lowering the ladder. Access to a "Back-up Bleed Down Valve" used to lower the ladder without power is provided at both ground and elevated levels.

Ground Level Ladder Operation

To raise the ladder from ground location: Move the electrical toggle switch to the UP position and hold it until the ladder reaches the UP position. Refer to illustration "Ground level ladder controls". The ladder will rise and lock in the UP position. **DO NOT attempt to operate the machine unless you are certain the ladder is LOCKED in the UP position.**



1. Mechanical Safety Latch Cable
2. Ground Level Toggle Switch

Figure 41. Ground level ladder controls

⚠ WARNING

Struck by or Crush hazards exist if personnel are in the travel area of the ladder when it is being lowered or raised. The ladder lowers and raises rapidly when engaged. Before lowering or raising the ladder, make sure all personnel are clear of the area. Being struck by the ladder or thrown off the machine could result in serious injury or death.

To lower the ladder from the ground location: Pull the hanging cable (Refer to illustration Ground level ladder controls to disengage the mechanical safety latch, then move the electrical switch to the DOWN position and hold it until the ladder reaches the DOWN position. The mechanical latch cable can be released once the ladder clears the mechanical latch. The ladder will lower and lock in the DOWN position.

Elevated Level Ladder Operation

To raise the ladder from elevated location: Move the electrical toggle switch to the UP position and hold it until the ladder reaches the UP position. Refer to illustration Elevated level ladder controls. The ladder will rise and lock in the UP position. **DO NOT attempt to operate the machine unless you are certain the ladder is in the UP position.**

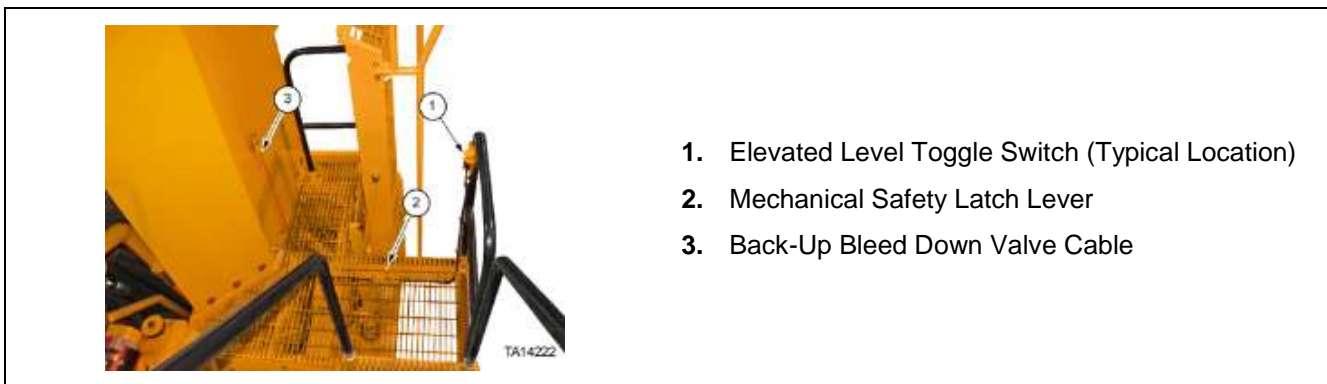

Figure 42. Elevated level ladder controls

To lower the ladder from the elevated location: Step on the "Mechanical Latch Activation Lever" to disengage the mechanical safety latch, then move the electrical switch to the DOWN position and hold it until the ladder reaches the DOWN position. Refer to illustration Elevated level ladder controls. The Mechanical Latch Activation Lever can be released once the ladder clears the mechanical latch. The ladder will lower and lock in the DOWN position.

Operating the Ladder without Electrical Power

If loss of electrical power to the ladder occurs, a "Back-up bleed Down Valve" is provided to allow hydraulic fluid release within the system, allowing the ladder to be lowered. The ability to actuate the "Back-up bleed Down Valve" is provided at the ground location (by direct access to the valve) and elevated location (by use of a cable attached to the valve).

⚠ WARNING

Struck by or Crush hazards exist if personnel are in the travel area of the ladder when it is being lowered by using the back-up bleed down valve. When lowering the ladder, be certain all personnel are a safe distance from the ladder. Lowering the ladder without power by activating the "Back-up Bleed Down Valve" causes the ladder to RAPIDLY lower NON-STOP until reaching ground level. Releasing the "Back-up bleed Down Valve" knob or cable will NOT stop the ladders' rapid decent to ground level. Being struck or crushed by the ladder could result in serious injury or death.

To lower the ladder from the ground location without electrical power: Pull the hanging Mechanical Safety Latch Cable to disengage the mechanical safety latch, then pull out the Back-up bleed Down Valve knob. The mechanical latch cable can be released once the ladder clears the mechanical latch. The ladder will lower and lock in the down position. Refer to illustrations “Mechanical safety latch cable (ground location) and Back-up bleed down valve (ground location access)” for details.

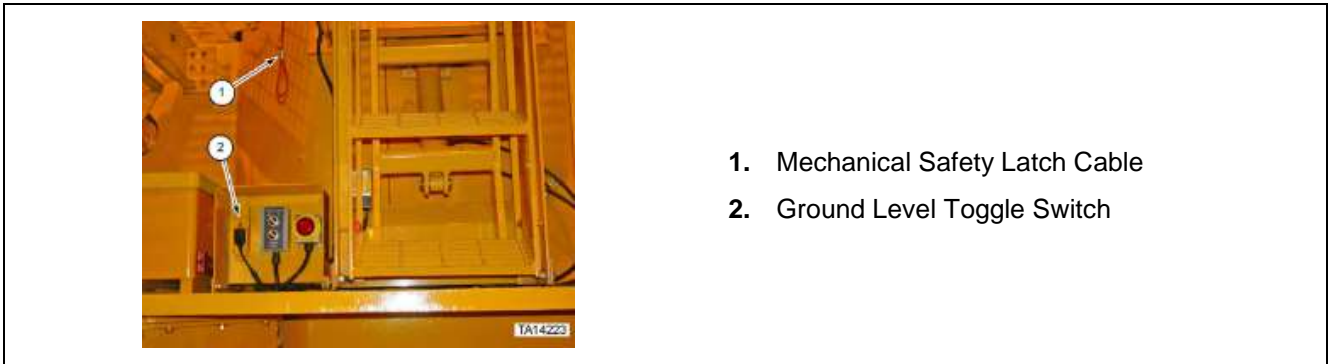

Figure 43. Mechanical safety latch cable (ground location)



Figure 44. Back-up bleed down valve (ground location access)

To lower the ladder from the elevated location without electrical power: Step on the Mechanical Safety Latch Lever to disengage the mechanical safety latch, then pull the Back-up Bleed Down Valve cable (refer to Back-up bleed down valve cable (elevated location access)). The Mechanical Latch Activation Lever can be released once the ladder clears the mechanical latch. The ladder will lower and lock in the DOWN position.

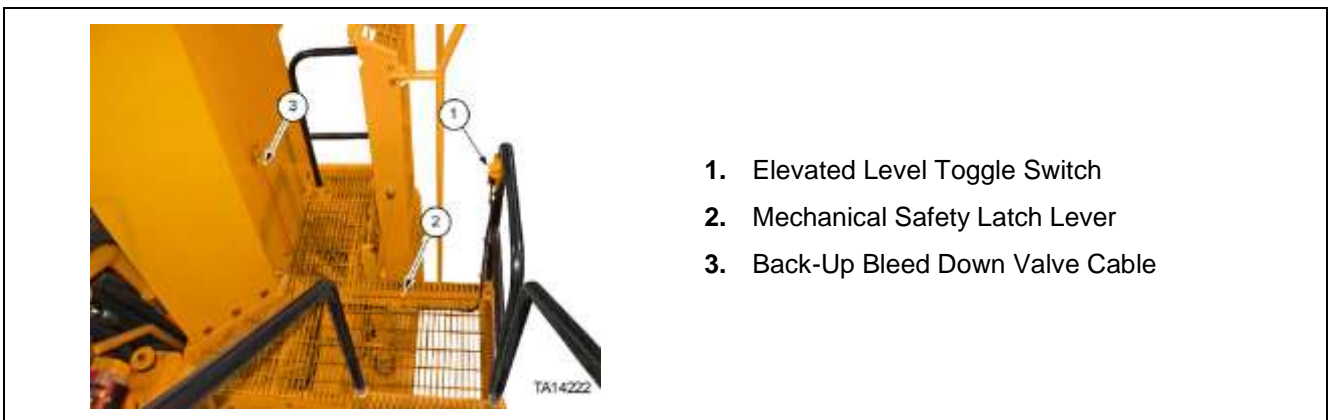

Figure 45. Back-up bleed down valve cable (elevated location access)

NOTICE

Before operating the ladder in normal mode, once power is restored, the "Back-up bleed Down Valve" must be reset by pushing it in until it reaches its' original position.

WARNING

Crush hazards exist from leaving the cab without setting the park brakes, which could result in unplanned and uncontrolled movement of the machine. The operator should never leave the cab with the park brake released. Set the park brake before leaving the cab. Leaving the cab without setting the park brake could cause a crush hazard from unexpected machine movement, resulting in property damage, serious injury or death.

Service, Inspection and Lubrication

Please refer to the vendor in Section 03 of the Service Manual.

This Page Intentionally Left Blank

Powered Access Ladder Hedweld Model “C”

Some machines are optionally equipped with a “Hedweld” model, powered access ladder mounted on the left rear of the rear frame.

Safe operation of the ladder depends on adherence to all safety warnings and cautions, and all safety rules required in the users area of operation. Periodic inspection and service must also be performed to the ladder to ensure safe and trouble-free operation.

WARNING

Struck by or Crush hazards exist if personnel are in the travel area of the ladder when it is being lowered or raised. The ladder lowers and raises rapidly when engaged. Before lowering or raising the ladder, make sure all personnel are clear of the area. Being struck by the ladder or thrown off the machine could result in serious injury or death.

Struck by or crushed hazard exists if personnel are in the travel area of the ladder when it is being lowered by using the back-up bleed down valve. When lowering the ladder, be certain all personnel are a safe distance from the ladder. Lowering the ladder without power by activating the "Back-up Bleed Down Valve" causes the ladder to RAPIDLY lower NON-STOP until reaching ground level. Releasing the "Back-up bleed Down Valve" knob or cable will NOT stop the ladders' rapid decent to ground level. Being struck or crushed by the ladder could result in serious injury or death.

WARNING

Fall hazard or Crush hazards exist if personnel rides the ladder up or down. Never ride the ladder up or down when it is being activated. Being struck by or crushed by the ladder could result in serious injury or death.

CAUTION

Component damage can result from attempting to ride the ladder up or down during operation. Do not ride the ladder up or down. Riding the ladder will void the manufacturer’s warranty and could result in component damage.

WARNING

Struck by or Crush hazards exist if the ladder is not de-energized prior to performing maintenance work on it. Place the ladder in the "DOWN" position and use Battery Isolation Switch to de-energize the ladder prior to performing any service operations to the ladder. Failure to de-energize the ladder prior to working on it could cause personnel to be struck by or crushed by the ladder, resulting in serious injury or death.

WARNING

Crush hazards exist if the park brake is not set before operating the ladder. Before raising or lowering the ladder, set the machine park brake. Uncontrolled machine movement could cause a hazardous condition when trying to enter or exit the ladder, which could result in serious injury or death.

⚠ WARNING

Fall hazard exists due to uncontrolled ladder movement if it is not placed in the full down position before entering or exiting the ladder. Place the ladder in the full DOWN position before entering or exiting the ladder. Serious injury is possible if the ladder is not in the full DOWN and LOCKED position before entering or exiting the machine.

⚠ WARNING

Fall hazard or crush hazards exists when operating the ladder or using it to enter or exit the machine. To avoid personal injury and component damage it is essential that all personnel using the ladder be familiar with its operation and all indicators and alarms. Falls and crush hazards are possible if personnel are not familiar with the ladder operation before using it, which could result in serious injury.

Normal Operation

Two box-mounted three-position momentary toggle switches are provided to raise and lower the ladder. One switch operates the ladder at ground level, the other operates the ladder from an elevated level. A lower, ground-level switch is mounted to the left of the ladder. The upper switch box is provided to allow operation after climbing and dismounting the ladder. (Refer to illustration Upper ladder switch).

Typical Operation at Ground or Elevated Levels

To raise the ladder: Push either switch to the UP position and release it. The ladder will rise to the UP position. The switches have a green LED that flashes while the ladder is in the UP cycle. Once the ladder is in the up position the green LED will remain illuminated without flashing. **DO NOT attempt to operate the machine unless you are certain the ladder is in the UP position.**

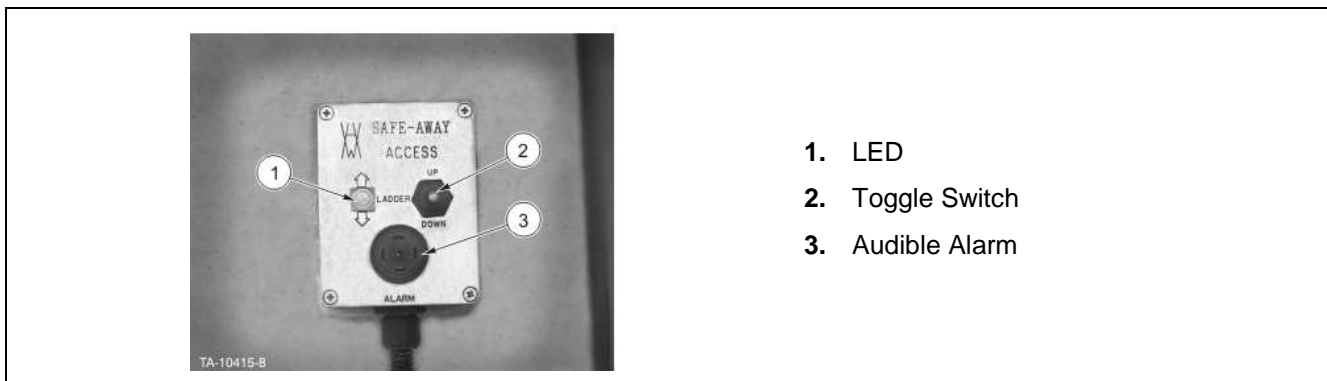

Figure 46. Upper ladder switch

To lower the ladder: Push either switch to the DOWN position and release it. The ladder will lower in the DOWN position. The switches have a red LED that flashes while the ladder is in the DOWN cycle. Once the ladder is in the down the red LED will remain illuminated without flashing.

NOTICE

If the park brake is released with the ladder in the DOWN position, an alarm is posted on the touch screen. Tractive power is inhibited until the operator raises the ladder to the full UP and LOCKED position. The park brake must be set again and re-released before the park brakes will release.

⚠ WARNING

Crush hazards exist from leaving the cab without setting the park brakes, which could result in unplanned and uncontrolled movement of the machine. The operator should never leave the cab with the park brake released. Set the park brake before leaving the cab. Leaving the cab without setting the park brake could cause a crush hazard from unexpected machine movement, resulting in property damage, serious injury or death.

Alarms: Prior to ladder operation, the green or red LED (as applicable to the ladder's position) should be illuminated and NOT flashing. A flashing red, green, or orange LED, prior to ladder operation, is an indication of a problem and the ladder should not be operated until it is repaired. Problems occurring during ladder operation result in an audible alarm accompanied by rapidly flashing, dim, or constantly on LEDs during the ladder's up/down cycles. Troubleshooting information for problems indicated by the various alarm codes is provided in the manufacturer's information, located in Section 03 of the Service Manual.

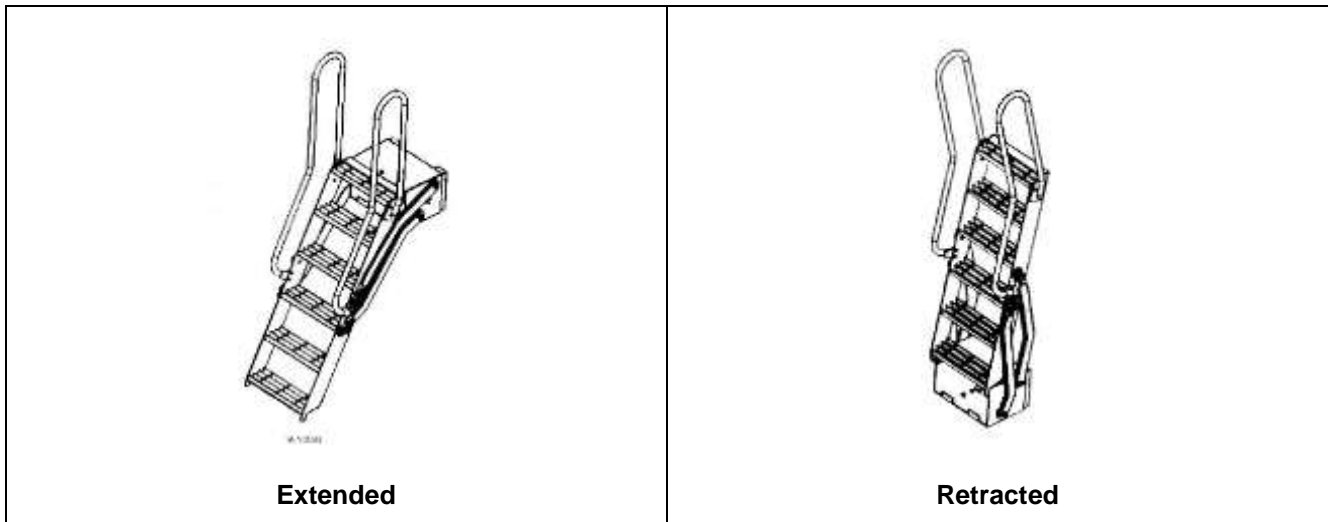

Figure 47. Powered access ladder

Operating the Ladder without Electrical Power

Should an emergency situation or mechanical problem occur, which results in loss of electrical power to the ladder, the ladder can still be lowered.

Loss of power to the ladder is sensed by the ladder's control system. When the up/down switches on either box are moved to the DOWN position, the emergency down circuit is actuated. A charged 24 VDC capacitor powers the ladder to the down position. The capacitor has power to lower the ladder only one time, it is recharged by reapplying power to the ladder.

Manual Release

The ladder can be manually raised or lowered by loosening the Allen-head screw on the ladder's control panel. Access the control panel is gained by raising the metal plate at the top of the ladder (Refer to illustration Ladder manual release).



Manual release (Located on ladder control panel at top of ladder)

Figure 48. Ladder manual release

Service, Inspection and Lubrication

Please refer to Section 03 of the Service Manual.

Komatsu Model

Some machines are optionally equipped with a “Komatsu” model, powered access ladder mounted on the left rear of the rear frame.

Safe operation of the ladder depends on adherence to all safety warnings and cautions, and all safety rules required in the users area of operation. Periodic inspection and service must also be performed to the ladder to ensure safe and trouble-free operation.

WARNING

Struck by or Crush hazards exist if personnel are in the travel area of the ladder when it is being lowered or raised. The ladder lowers and raises rapidly when engaged. Before lowering or raising the ladder, make sure all personnel are clear of the area. Being struck by the ladder or thrown off the machine could result in serious injury or death.

WARNING

Fall hazard or Crush hazards exist if personnel rides the ladder up or down. Never ride the ladder up or down when it is being activated. Being struck by or crushed by the ladder could result in serious injury or death.

CAUTION

Component damage can result from attempting to ride the ladder up or down during operation. Do not ride the ladder up or down. Riding the ladder will void the manufacturer’s warranty and could result in component damage.

WARNING

Struck by or Crush hazards exist if the ladder is not de-energized prior to performing maintenance work on it. Place the ladder in the "DOWN" position and use Battery Isolation Switch to de-energize the ladder prior to performing any service operations to the ladder. Failure to de-energize the ladder prior to working on it could cause personnel to be struck by or crushed by the ladder, resulting in serious injury or death.

WARNING

Crush hazards exist if the park brake is not set before operating the ladder. Before raising or lowering the ladder, set the machine park brake. Uncontrolled machine movement could cause a hazardous condition when trying to enter or exit the ladder, which could result in serious injury or death.

WARNING

Fall hazard exists due to uncontrolled ladder movement if it is not placed in the full down position before entering or exiting the ladder. Place the ladder in the full DOWN position before entering or exiting the ladder. Serious injury is possible if the ladder is not in the full DOWN and LOCKED position before entering or exiting the machine.

WARNING

Fall hazard or crush hazards exists when operating the ladder or using it to enter or exit the machine. To avoid personal injury and component damage it is essential that all personnel using the ladder be familiar with its operation and all indicators and alarms. Falls and crush hazards are possible if personnel are not familiar with the ladder operation before using it, which could result in serious injury.

Typical Operation

The ladder is powered by an air cylinder which receives pressure from the compressed air system.

Safe operation of the ladder depends on adherence to all safety warnings and cautions, and all safety rules required in the users area of operation. Periodic inspection and service must also be performed to the ladder to ensure safe and trouble-free operation.

Normal Operation at Ground or Elevated Levels

The valve for raising and lowering the ladder is located just behind the cab, on the rear of the Low Voltage Control Cabinet (LVCC). The switch is a lever-operated toggle valve which is pulled up to retract the ladder and pushed down to lower the ladder.

Refer to illustration Powered rear access ladder switch. Powered DO NOT attempt to operate the machine unless you are certain the ladder is in the UP position. Refer to Parts Manual for air schematic.



TA-9239

Figure 49. Powered rear access ladder switch

Service, Inspection and Lubrication

Please refer to the vendor in Section 03 of the Service Manual.

Machine Mechanical Operating Concerns

The operator should be continually aware of the indicator lights, gauges, audible alarm and monitor screen messages. He/she should also be alert to any unusual noises, vibrations, smoke, fluid leaks or odors that might signal problems with the loader or become a potential fire hazard. Prompt and correct action by the operator in the event of trouble is often required to prevent costly repairs and downtime. It is also essential for the operator to correctly operate the machine to prevent damage to various components. We especially draw your attention to “Overspeed Prevention Recommendations” located within this section.

NOTICE

When operating in cold climates, the oil pressure indications will be higher after starting, during engine warm-up, and when HI throttle is selected. It will take longer for the oil to warm-up and for the oil pressure to reach normal operating temperature.

Computer Monitor

(Refer to “Cab control console”)

The Komatsu on-board control system monitors various functions of the loader for problems and provides diagnostic data for maintenance personnel. Two lights – red and yellow -- are provided to alert the operator of problems with engine, electrical, hydraulic, pneumatic, and electronic systems. An audible alarm accompanies the red and yellow lights.

The machine is equipped with either a Detroit Diesel or Cummins engine. The Detroit Diesel or Cummins (as applicable) diagnostic and warning system is integrated into the overall machine alarm and monitoring system functions. The red and yellow lights will activate upon receiving appropriate messages from the engine’s diagnostics.

- The Red Alarm light indicates a serious problem that requires shutdown of the machine. Operation should not be resumed until the problem has been corrected. An engine problem that causes the Red Alarm light to glow will inhibit propel and the machine comes to a complete stop. A message will appear on the touch screen. The machine must be stopped and the engine must be shut down immediately by using the normal engine shutdown procedure (key switch).
- The yellow warning light indicates that a problem may not require immediate shutdown of the engine but **MUST BE INVESTIGATED** and addressed. In the event an engine related problem results in the yellow light glowing, a message will appear on the touch screen. The engine should be operated to transport the machine to the maintenance area for diagnosis of the problem only.
- An audible alarm is activated when the red or yellow lights illuminate.
- When a yellow warning light illuminates, a warning message appears on the touch screen to advise the operator of the nature of the warning which activated the light. The operator can remove the message from the screen and silence the audible alarm by pressing the Acknowledge Switch on the left joystick. The warning message leaves the screen but will remain in the system (in the log file) for access by repair technicians. The light will continue to glow until the warning condition is corrected.
- When a red alarm light illuminates, an alarm message appears on the touch screen to advise the operator of the nature of the alarm which activated the light. The operator can remove the message from the screen and silence the audible alarm by pressing the Acknowledge Switch on the left joystick. However a red alarm causes an engine shutdown timer to activate, if the park brake is set, the engine is immediately shutdown. If the machine is moving, a countdown timer indicates the amount of seconds before the park brake is automatically set and the engine is shutdown. The alarm message is stored in the system for access by repair technicians. The light will continue to glow until either the LINCS system is rebooted or the red alarm is cleared by a service level technician.

Auxiliary Steering System (Optional)

The auxiliary steering system employs the use of two 24-VDC, 9-horsepower motor-driven pumps with the machine's four batteries as the 24-VDC power source. The optional auxiliary steering system automatically activates if the hydraulic steering system pressure drops below 30 psi during normal machine operation. When the Auxiliary Steering system is activated, the LINCS II computer system activates the Red Alarm light, an audible alarm sounds, and a Red Alarm message appears on the touch screen. As with all Red Alarms, the machine comes to a stop, propel is inhibited, a Red Alarm light illuminates and the audible alarm sounds. The machine comes to an abrupt stop. Should this occur, SHUT THE ENGINE DOWN as soon as safely possible, by using the normal engine shutdown (key switch) procedure.

WARNING

Crush hazards exist from uncontrolled machine movement if the auxiliary steering system fails. Auxiliary steering is ONLY a backup system. If something occurs in the normal steering system, auxiliary steering should only be used to steer the machine to a stopped position. It should NEVER be used in material handling operations. Loss of steering could cause a crush hazard by uncontrolled machine movement resulting in serious injury or loss of life.

Diesel Engine Operational Concerns

NORMAL ENGINE SHUTDOWN: It is critically important to allow the engine to run at the low throttle setting for five minutes before shutting down the engine. When a turbocharged engine is stopped immediately, the turbochargers continue to turn without an oil supply to the bearings. Allowing the engine to run at low throttle for five minutes also cools the bearings and seals in the turbochargers. If the engine is stopped suddenly, the turbocharger temperature may rise as much as 100°F (38°C) over normal safe operating temperature. The results of the extreme heat may be seized bearings or loose oil seals.

An automatic idle timer is programmed into the LINCS II Computer System. The engine must run at low throttle for five minutes before the computer system shuts it down (except in certain alarm conditions). When the Key Switch/Crank Switch is turned to the OFF position to stop the engine, the computer system checks the previous low throttle time prior to turning off the key, then adds enough time to the timer to total five minutes before turning off the engine. The LINCS II Computer System will remain booted up. After a total of five minutes at low throttle, the engine will stop but the LINCS II Computer System will remain booted up for an additional 15 seconds. If the Key Switch/Crank Switch is turned back to the ON position during this 15-second interval, the LINCS II Computer System will remain booted up until the Key Switch/Crank is once again turned to the OFF position. It is NOT recommended to stop the engine immediately after it has been run at hi throttle as damage to engine components is possible.

EMERGENCY ENGINE SHUTDOWN: Never use the emergency shutdown system except in an emergency. Using the emergency shutdown system can cause serious damage to the engine components such as the turbochargers. If the emergency shutdown system is activated, a qualified and experienced technician should check the engine before the machine is returned to service.

CAUTION



Burn hazard exists from hot fluids or steam when removing the radiator cap if it is not allowed to cool down before opening. Allow the engine cooling system to cool before removing the radiator cap. Do not remove radiator cap while pressure remains in the system. Hot fluids escaping can cause serious burns.



1) Radiator Cap, 2) Manual Pressure Relief Valve, 3) Sight Glass

Figure 50. Radiator cap

EMERGENCY JUMP STARTING: It is possible to damage the solid-state electronic controls of the machine and engine if jumper cables are connected improperly or arcing occurs. The possibility of serious personal injury is also possible. Therefore, Komatsu recommends that the machine is only jump started with the jumpstart connections.



Located inside the “isolation and control switches assembly”, left rear of machine, beside ladder/step area.

Figure 51. Jump start socket

AVOID UNNECESSARY ENGINE IDLING: During long engine idling periods, the engine coolant temperature will fall below the normal operating range. The incomplete combustion of fuel in a cold engine, causes crankcase dilution, formation of lacquer or gummy deposits on the valves, pistons, and rings, and causes rapid accumulation of sludge in the engine.

ENGINE PROBLEMS - EARLY WARNING SIGNS: Most engine problems give an early warning. Look and listen for changes in performance, sound or engine appearance that can indicate service or engine repair is needed. Some changes to look for are as follows:

- Engine misfires
- Unusual engine noises
- Excessive vibration
- Excessive smoke
- Fuel, oil or coolant leaks
- Sudden changes in engine operating temperature or pressure
- Loss of power

- An increase in the rate of fuel consumption
- An increase in the rate of oil consumption

CAUTION

Damage to the engine electronic control system is possible when welding on the machine. To prevent damage to the engine electronic control system, disconnect the following **BEFORE** welding: battery power and ground cables and the power connector at the engine Electronic Control Module (ECM). Failure to isolate the engine electronic control system from high current (possible occurrence as a result of welding) can result in severe ECM damage.

Hydraulic System Monitoring and Operational Concerns

If a warning light and its accompanying text message indicate a problem with the hydraulic system, perform the following procedure:

WARNING

Crush hazards exist when using the Manual Bleed Valve Assembly to relieve pressure from the hoist and bucket circuits if personnel are in the area of the bucket or lift arms. Always depressurize the hydraulic hoist and bucket circuit when working on the hoist and bucket hydraulic circuit. Operating the manual bleed valve may cause the lift arms and bucket to descend rapidly. All personnel shall stand clear of the lift arms and bucket areas before the Manual Bleed Valve Assembly is used to relieve hoist and bucket circuit pressure. Before performing any procedure on any hydraulic component within the hoist and bucket circuit, the valves shall be used to relieve residual system pressure from the hoist and bucket circuits. The Hoist and Bucket Hydraulic Circuit Manual Bleed Valve Assembly shall not be operated when the engine is running. Failure to clear the bucket and lift arm areas of personnel prior to operating the valve assembly can cause a crush hazard resulting in serious injury or death.

- Stop the machine.
- Lower the bucket to the ground.
- Select low throttle.
- Set the park brakes.
- Turn the Key Switch/Crank Switch to the OFF position.
- Press and hold the Acknowledge Switch for 2 seconds to bypass the idle timer.

NOTICE

Normal shutdown procedures require that the engine be run in LO throttle for five minutes or more. But in the case of an emergency, turn the Key Switch/Crank Switch to the OFF position immediately. Running the engine for five minutes helps prevent cavitation in the hydraulic pumps.

- Get out of the machine and check the hydraulic reservoir sight gauge.
- If the hydraulic oil sight gauge shows that the quantity of hydraulic oil is at a safe level, call for a maintenance check on the hydraulic oil cooling system.
- If the hydraulic level is low and the reservoir must be filled, observe the following warning.

 **CAUTION**

Burns and struck-by hazards are present if pressure is not relieved before removing the hydraulic fluid reservoir filler cap. Hot oil could be present and could be unexpectedly expelled from the system when opening the reservoir filler cap if the reservoir is not depressurized. Burns from hot oil is possible. Air pressure in the reservoir could cause uncontrolled movement of the cap if it is removed without depressurizing the reservoir. Always release air pressure in the hydraulic reservoir before servicing or repairing anything requiring removal of the reservoir filler cap. Release of the reservoir air pressure is done by turning the manual air release valve to the OPEN position. The air pressure in the reservoir will be released, and at the same time, the valve will lock in the air pressure in the rest of the system. After servicing, repairing or inspecting the hydraulic oil reservoir, make certain to turn the manual air release valve (refer to “Hydraulic reservoir air release valves”) to the CLOSED position to pressurize the reservoir. Failure to release the air pressure from the hydraulic reservoir before removing the filler cap could cause burns or struck-by hazards resulting in injury.

NOTICE

Whenever there is a hydraulic leak (such as a leaking O-ring or hose) release the air pressure from the hydraulic reservoir to prevent further loss of hydraulic fluid.

NOTICE

When the emergency stop or fire suppression systems are actuated, the automatic air release valve (refer to “Hydraulic reservoir air release valves”), located on top of the hydraulic reservoir, will automatically release air pressure from the hydraulic reservoir. Once tripped, the valve must be manually reset by pushing the button IN to the closed position.

Grade Stability



Crush hazards exist if exceeding the parameters shown in figure “Allowable Grade Parameters”. This could result in machine rollover/tip-over. Do not exceed the parameters shown in “Allowable Grade Parameters” shown below. Machine rollover/tip-over can cause crush hazards which could result in equipment damage, serious injury or death.

Komatsu equipment is designed to operate safely when all operating parameters are maintained. DO NOT exceed the following Allowable % Grade parameters when operating the machine.

Empty Bucket in Carry Position

| Machine Position | Travel Speed Limit | Allowable % Grade |
|--|-------------------------|-------------------|
| Fully Articulated / Slope Side to Side | Creep (less than 1 mph) | 10% |
| No Articulation / Slope Side to Side | 2.5 mph | 14% |
| No Articulation / Fore and Aft | 2.5 mph | 20% |

Empty Bucket in Raised Position

| Machine Position | Travel Speed Limit | Allowable % Grade |
|--|-------------------------|-------------------|
| Fully Articulated / Slope Side to Side | Creep (less than 1 mph) | 10% |
| No Articulation / Slope Side to Side | 2.5 mph | 10% |
| No Articulation / Fore and Aft | 2.5 mph | 20% |

Figure 52. Allowable grade parameters

Overspeed Prevention Recommendations

- a. Observe actual grade conditions as compared to the grade/speed chart for both loaded and unloaded conditions. The grade/speed chart is located inside the cab (refer to “Typical grade/speed chart”).
- b. Reduce speed PRIOR to descending a grade.
- c. As a general rule: descend a grade no faster than what the machine will ascend the same grade with the same load.
- d. Promptly apply service brakes to slow the machine if an overspeed situation occurs.
- e. The machine should only be operated on less than 4 motors to move it away from a dangerous situation where it can be repaired. Do not operate the machine with less than 4 motors.

| | |
|--|--|
| | <div style="background-color: #0056b3; color: white; text-align: center; padding: 5px; font-weight: bold; font-size: 1.2em;">NOTICE</div> <p>Due to variations in drive components, an example grade/speed chart is shown here. Refer to the grade/speed chart mounted in the operator’s cab for accurate information.</p> |
|--|--|

Figure 53. Typical grade/speed chart

Braking

There are three systems used to slow down or stop the machine: Dynamic, Service, and Park. Dynamic braking is the primary system for slowing down or stopping the machine.

Dynamic

The service brakes and park brakes are back up systems for the dynamic braking system, which is the machine's primary braking system. Dynamic braking utilizes electrical and mechanical systems to achieve slowing down or stopping the machine.

Service

Depressing the Service brake pedal activates the air-release service brakes. The primary function of the service brakes is to hold the machine while on grades or when in close proximity to material hauling vehicles or for emergency stops. The service brakes are NOT intended to routinely stop the machine during material handling operations. Use of the service brakes to routinely stop the machine during material handling operations will result in rapid wear of the disc pads and rotors.

NOTICE

It is natural for operators to equate stopping the machine with stopping a highway vehicle, which requires depressing the brake pedal to stop. Therefore, it is essential to train operators in the function and capability of the machine's dynamic braking system to avoid accelerated wear of the disc pads and rotors.

Park

The function of the park brake is to hold the machine while parked. The park brake is applied with the console-mounted switch. When the park brake or service brake is set, propel is inhibited.



WARNING

Crush hazards exist if the park brake is not set before operating the ladder. Before raising or lowering the ladder, set the machine park brake. Uncontrolled machine movement could cause a hazardous condition when trying to enter or exit the ladder, which could result in serious injury or death.

Bucket Rollback Stop Blocks and Bell Crank Stop Blocks

It is essential that the operator visually inspect the bucket rollback stop blocks and bell crank stop blocks as part of the daily walk-around inspection. If the stop blocks are damaged, missing or excessively worn, they must be replaced immediately or damage to the lift arms and other components could occur (refer to "Bucket rollback and bell crank stop block inspection" and bucket rollback and bell crank stop block replacement procedures, located in Section 3, MECHANICAL, STRUCTURAL, of the Service Manual).

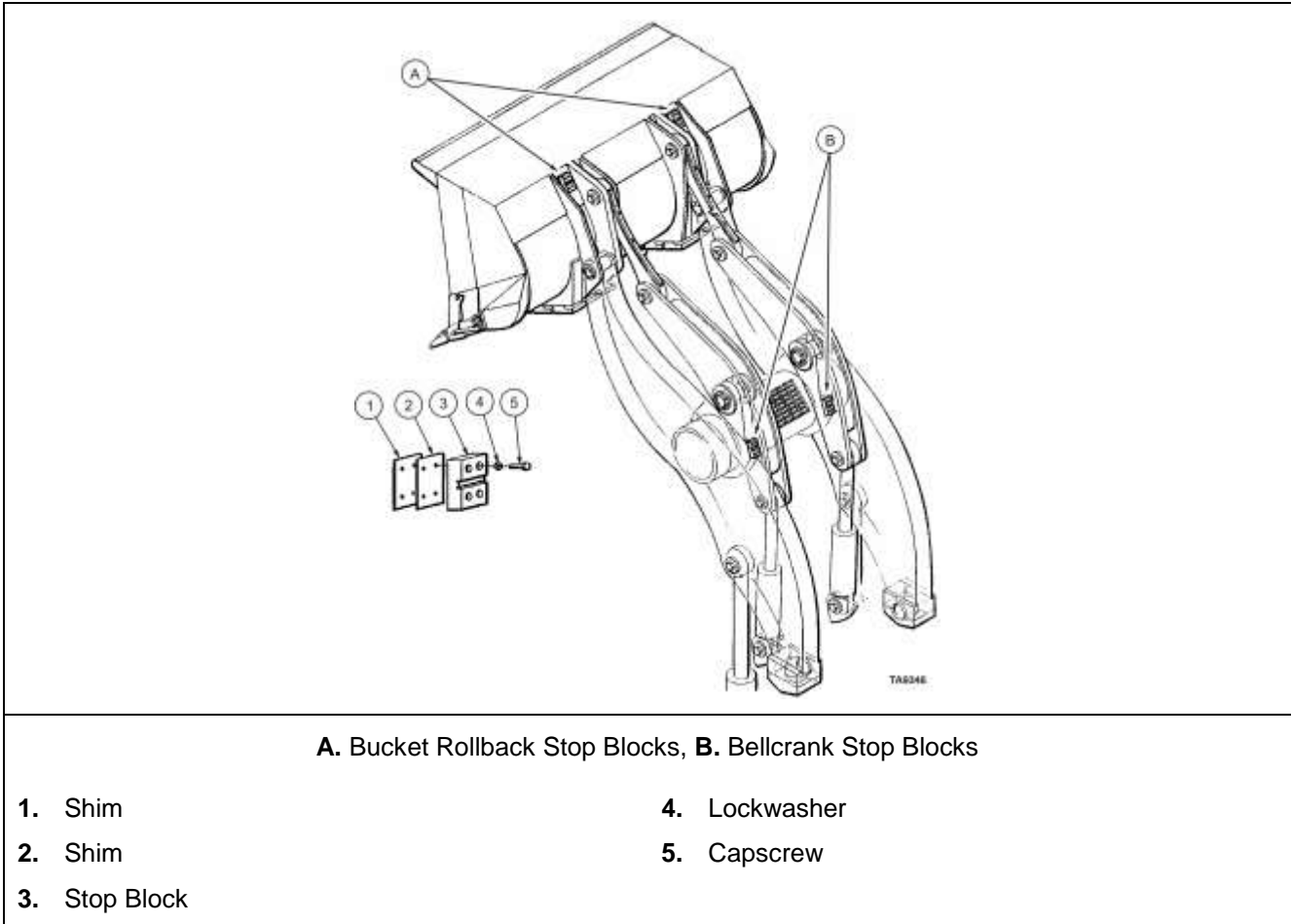

Figure 54. Bucket rollback and bell crank stop block inspection

Basic Machine Operating Instructions Non-Material Handling Operations

The following instructions are for the basic operations of the controls and engine start up and shut down (non-material handling operation). It is **ESSENTIAL** for operators of the loader to read and understand all instructions contained in this Service Manual pertaining to machine operation and safety before operating the loader. We especially draw the reader's attention to the information contained in Section 1. The engine manufacturer's owner's manual(s) (available on the manufacturer's website) should also be reviewed for any special instructions pertaining to operation and maintenance of the engine. These instructions cover various options that may or may not be found on your machine.

If there are ANY questions after reading the instructions contained in this Service Manual and the engine manufacturer's owner manual, call a Komatsu Service Center or the engine manufacturer's local authorized service center to have the problems resolved **BEFORE** operating the machine.

WARNING

Crush hazards exist if uncontrolled machine movement occurs. Before starting the engine, ensure the machine is in a place that is safe for operations. The machine should be on a level area, and all personnel and equipment must be clear of the area. After the starting procedures and observations have been made, and it is determined the loader is safe to operate, it can be moved. Starting the machine in an area that is not safe to operate could cause a crush hazard resulting in serious injury or death.

WARNING

Crush hazard exists if non-essential personnel are not alerted to stay clear of machine during operational/energized inspections. Crush and electrical hazards exists during operational maintenance procedures. Failure to alert personnel of machine movement can cause crush hazards which result in serious injury or death.

NOTICE

Use of the machine in material handling operations is covered within this section entitled "Basic Machine Operating Instructions Material Handling Operations".

- **ANYONE** performing inspections or service procedures to the machine should be familiar with **ALL** appropriate instructions and procedures.

Pre-Starting Procedures

Perform the following procedures before starting the engine (refer to “Cab control console”):

CAUTION

Equipment damage is possible if the machine is moved after starting the engine. BE SURE the frame lock has been removed and secured before starting the engine. Moving the machine with the frame lock in the locked position could cause serious machine damage.

- a. Adjust the operator’s seat to a comfortable position to safely operate the controls. Make sure that the seat is adjusted so that your right foot reaches the speed control pedal, whereby you can FULLY RELEASE the pedal as well as press the pedal down.
- b. Fasten and adjust the seat belt.
- c. Place the directional switch in the neutral (center) position. The switch must be in the neutral position to start the engine.
- d. Check that the park brake is in the park (PRESSED IN) position.
- e. Place the Throttle Switch in the LOW position.
- f. Turn the Key Switch/Crank Switch to the ON position. If no faults are present which would inhibit the start function, the engine is ready to be started. If a problem exists which will inhibit the start function, a message indicating the nature of the problem appears on the screen (if it is booted up).
- g. Ensure the Battery Isolation and Starter Isolation switches are in the “ON” position. The switches cannot be locked in the “ON” position, they CAN be locked in the “OFF” position. In the “ON” position the red and yellow indicator lights will be illuminated, indicating the machine engine can be started.

Starting the Engine

After the above measures are taken, the engine is ready to start.

WARNING

Entanglement in the drive shaft or engine belts, burns if working on the engine exhaust or around hydraulic fluid or engine fluid, cuts/dismemberment if working on the radiator fan, electrical shock if working on the electrical system, skin injection from hydraulic fluid if working on high pressure side of hydraulic system, hearing loss from sonic sounds if working inside KLENZ system and other hazards exist. ALWAYS sound the horn for 2-3 seconds prior to starting the engine to alert personnel on the machine or in close proximity to it that the engine is about to start. Allow at least 30 seconds for them to clear the area before starting the engine. Check wing mirrors and all sides of machine from a seated position. If the horn is inoperable (see the following NOTICE), and if allowed by local rules and regulations, dismount the machine, and walk around it to be sure no one is on the machine or in close proximity to it before starting the engine. Always follow all local startup procedures before starting the machine. Failure to allow ample time for personnel to leave the area before starting the engine could cause entanglement, burns, cuts/dismemberment, electrical shock, hearing loss, skin injection, and other hazards resulting in serious injury or death.

NOTICE

Compressed air system pressure powers the pneumatic horn and releases the park brake. Air pressure may, on occasion, bleed off after the loader has been parked for a set amount of time. This will result in the horn being inoperable until the engine is started, which provides compressed air

system pressure. If blowing the horn is required by local rules and regulations, before starting the machine, the air system can be manually charged by an external source.

Starting Detroit Diesel Equipped Machines

Turn the Key Switch/Crank Switch firmly to the START position. If the engine fails to start within 20 seconds, release the Key Switch/Crank Switch and allow the starting motor to cool at least two minutes before trying to start again. If the engine fails to start after four attempts, an inspection should be made to determine the cause. **Refer to the CAUTION below.**

Starting Cummins Engine-Equipped Machines

CAUTION

Starter damage is possible. To prevent serious damage to the starter, if the engine does not start, DO NOT turn the Key Switch/Crank Switch to the START position again while the starter motor is still running.

Observe the oil pressure gauge immediately after starting the engine. If there is no oil pressure indicated within 10 to 15 seconds, stop the engine and check the lubricating system.

NOTICE

Cummins engines utilize a pre-lube system, which builds up the engine oil pressure prior to starting the engine. The Key Switch/Crank Switch must be held in the START position while the pre-lube system is in operation. Cummins engines WILL NOT start immediately when the Key Switch/Crank Switch is turned to the START position.

Turn the Key Switch/Crank Switch firmly to the START position. This will energize a pre-lube motor. When the oil pressure reaches 4 psi, the pre-lube motor turns off and the normal start circuit will function.

If the engine fails to start within 20 seconds, release the Key Switch/Crank Switch and allow the starting motor to cool at least two minutes before trying to start again. If the engine fails to start after four attempts, an inspection should be made to determine the cause.

After Starting the Engine

- a. Run the engine at the low throttle position with no load for approximately five minutes, allowing it to warm up before applying a load.

NOTICE

During cold weather starts, the engine should be warmed up at least 10 minutes or until the engine temperature gauge indicates at least +120°F (49°C). Normal operating engine coolant temperature is +160°F to +190°F (71°C to 88°C).

- b. Check all instruments and indicator lights. For operation of the motor and machine, the following must be true:
 - Alarm/Warning lights should be off.
 - The water temperature gauge should read at least +120°F (49°C).
 - The oil pressure gauge should read at least 15 psi.
 - The air pressure gauge should read at least 110 psi.

- c. Select hi throttle and recheck instruments and indicator lights.

NOTICE

During cold weather it may take more than 30 minutes operation for the hydraulic oil to reach its normal operating temperature of 140°F to 160°F (60°C to 71°C).

WARNING

Crush hazards exist in machine pivot area and area between the front and rear tires. Do not enter these areas unless it is verified that the operator has control over the steering and that personnel locking the frame lock have good communication with the operator. Entering the pivot area and area between the tires while the machine is moving or pivoting (articulating) could cause crush hazards resulting in serious injury or death.

- d. Select hi throttle and recheck instruments and indicator lights.

Operating the Machine (Non-Material Handling Operations)

After the starting procedures and observations above have been made, and it is determined the loader is safe to operate, it can be moved.

Test the Hoist and Bucket Functions

WARNING

Crush hazards exist if uncontrolled machine movement occurs. Do not test the functionality of the hoist/bucket, steering, or brakes, unless the machine is in a place that is safe for operations. The machine should be on a level area, and all personnel and equipment must be clear of the area. After the starting procedures and observations have been made, and it is determined the loader is safe to operate, it can be moved. Crush hazard is possible from uncontrolled machine movement and could result in serious injury or death.

NOTICE

The following instructions cover the basics of only moving and shutting down the machine. Use of the machine in material handling operations is covered in detail in “Basic Machine Operating Instructions Material Handling Operations”, located within this section.

- a. Pull the hoist control joystick back to raise the bucket off the ground.
- b. When the bucket rises to about three (3) feet high, return the hoist control joystick back to the center position to stop movement of the lift arms.
- c. Use the bucket control switch (roller switch) on the hoist joystick or move the hoist joystick to the left to roll back the bucket. Release the bucket control switch (roller switch) or move the joystick back to center when the bucket reaches the full rollback position.

NOTICE

It is recommended that the bucket be three to four feet off the ground and rolled back when the machine is traveling. Bucket angle can be verified by checking the bucket angle gauge on the screen, (refer to illustration “Cab control console”).

Test the Steering Function

- a. Release the park brakes by pulling the parking brake control **OUT**.

NOTICE

The park brakes cannot be released until compressed air system pressure has reached about 110 psi on the air pressure gauge.

- b. Move the directional control switch to the desired position.
- c. **SLOWLY** press the speed control pedal and steer the loader slightly left and right to make sure the steering system is operating normally.

NOTICE

The speed of the machine is proportional to the amount the speed control pedal is depressed.

Test the Dynamic Brake Function

- a. Immediately after traveling 10 to 15 feet, release the speed control pedal to determine that dynamic braking is occurring. The machine should come to a complete stop on level ground.

Test the Service Brake Pedal

- a. Press the speed control to operate the machine to approximately 5 mph. Slowly release the speed control. Slowly depress the service brake. The machine should come to a complete stop.

NOTICE

Always depress and release the speed control pedal slowly and smoothly. Abrupt movement of the speed control pedal will result in a sudden response from the loader's drive motors. Sudden and complete release of the speed control pedal will apply full dynamic braking.

When the loader is on a grade, it will not come to a full stop until the Service Brake pedal is applied.

NOTICE

The service brake pedal should **NOT** routinely be used to stop the loader during normal operation. The loader should be stopped by releasing the speed control pedal and utilizing the dynamic braking system. Use of the service brakes to routinely stop the loader during material handling operations will result in accelerated wear of the disc pads and rotors.

However, when required, service brakes could be used to prevent movement of the loader while in close proximity to a transport vehicle or to hold the loader on a grade.

Changing Directions (Forward and Reverse)

The machine's direction, FORWARD or REVERSE, can be selected without releasing the speed control pedal. Once the directional control switch is moved to the opposite direction, the machine's control system automatically applies dynamic braking, slows the machine to a complete stop and then changes the machine's direction. While this change of direction is being processed by the control system, the speed control pedal can remain fully depressed. This will ensure cycle times are maximized and there is no wasted time selecting direction.

Normal Shutdown Procedures

After operation of the machine, or if the machine will be left unattended, the following procedures should be followed for normal shutdown:

- a. Move the machine to the desired location.
- b. Position the bucket, level on the ground.
- c. Push the parking brake switch IN to engage the park brake.
- d. Move the directional control switch to the neutral (center) position.
- e. Select low throttle.
- f. Turn the Key Switch/Crank Switch to the OFF position.
 - If the engine has been running for a set amount of time, turning the Key Switch/Crank Switch to the OFF position activates the idle timer,
 - The idle timer allows the engine to run at low throttle for five minutes to cool various components including the engine turbochargers.
 - The LINC'S II Computer System remains booted up during the idle timer shutdown process.
 - When the idle timer is activated, the touch screen provides a screen indicating the idle timer is operating.
 - After five minutes, the engine fuel flow to the injectors is stopped, which stops the engine.
 - The LINC'S II Computer System remains booted up for an additional 15 seconds. During this 15-second interval, the Key Switch/Crank Switch can be switched back to the ON position and the LINC'S II Computer System will remain booted up.
 - This function saves waiting the normal boot-up time to complete service work, data transmission, etc.
 - If the Key Switch/Crank Switch is not switched back to the ON position during the 15-second interval, the LINC'S II Computer System switches off and the touch screen turns off.
 - If the Key Switch/Crank Switch is turned back to the ON position to keep the LINC'S II Computer System booted up, turning it back to the OFF position immediately boots the computer system down.

NOTICE

The idle timer can be bypassed by pressing and holding the acknowledge button for 2 seconds during the idle timer process. This will immediately shut down the engine and LINC'S II Computer System. Bypassing the idle timer can cause damage to the turbochargers. Shutting the engine down immediately should only be done in emergency situations.

Emergency Shutdown

The operator's cab is equipped with an emergency stop button for use in emergency situations. Emergency stop switches are also located at ground level on each side of the loader. These switches should NEVER be used for routine shutdown of the engine as damage to components could occur. They should only be used in emergency situations. Following their use, a complete inspection of the engine must be made by a qualified technician to ensure no damage has occurred. When the emergency shut down system is actuated, air pressure in the hydraulic reservoir is automatically released by the automatic air release valve, located on top of the hydraulic reservoir. This valve must be manually reset by pushing the button on the switch IN to the closed position.

This Page Intentionally Left Blank

Basic Machine Operating Instructions Material Handling Operations

General Material Handling Operations and Precautions

The following instructions are for operating the loader in basic material handling operations. These instructions are provided as a guide to safe and productive operations. Operating the loader under different job situations may require additional measures than are described herein.

NOTICE

All lift capacities and machine operating characteristics are based on the criteria of the machine being level, on firm supporting ground. When the machine is operated in conditions that deviate from these criteria (e.g. on soft or uneven ground, on slope or when subject to slide loads), these conditions shall be taken into account by the operator.

WARNING

Special hazards may exist. Before operating the equipment, it must be determined if special hazards exist in the operating area, such as toxic gasses, ground (underfoot) conditions, that require special precautions or measures to eliminate or reduce the hazard. If special hazards exist (e.g. lines: gas, electricity) in the ground: close overhead electric lines: below ground in enclosed areas: contaminated areas: other special conditions: local rules and regulations shall be followed. Serious injury or death is possible.

Before the loader is used in material handling operations, the operator(s) should have a good understanding and demonstrated ability of the following:

- a. All controls, warning and indicator lights, gauges, touch screen, and any special instructions concerning engine start-up, operation and shutdown as provided in this manual and the engine manufacturer's owners manual.
- b. Basic operation of the loader with regards to maneuvering, traveling, starting and stopping, changing directions (forward/reverse) and hoist and bucket functions as described in "Basic Machine Operating Instructions Non-Material Handling Operations", located within this section.
- c. Operation of the loader to ensure mechanical components are operated and monitored in a manner that will provide safe and cost effective material handling operations as described in "MECHANICAL OPERATING CONCERNS", located within this section of the manual.
- d. The safety instructions contained within this Manual and knowledge of company safety policy in regards to operating the loader in material handling operations.
- e. Knowledge of the job site and terrain to ensure safe machine operation to avoid damage to the loader or vehicles being loaded.

It is ESSENTIAL to observe the following operating practices and precautions to prevent damage to the loader and vehicles being loaded:

Know the material to be loaded. Overloading the bucket can damage the lift arms, main frame, and hydraulic equipment.

- NEVER try to raise an overloaded bucket to additional height by bouncing it.
- NEVER let any part of the loader touch any part of the truck or hopper being loaded.

- NEVER use the loader as a dozer; it is not designed as a dozer.
- NEVER jack the loader up by using the bucket and lift arms.
- When traveling pit-to-pit, shop-to-pit, pit-to-shop, etc., the loader bucket should be carried three (3) to four (4) feet off the ground in a full rollback position.

CAUTION

Equipment damage is possible. Do not corner load the bucket. Damage to the lift arms could occur. In all bucket-loading cycles, approach the face or stockpile with the bucket square and the loader straight (not articulated). The bucket should always be loaded close to the ground.

CAUTION

Equipment damage is possible. As the loader bucket enters or exits the pile, do not spin or bounce the tires. Spinning the tires could cause serious damage to the drivers and traction motors.

CAUTION

Equipment damage is possible. NEVER enter the pile at full speed. This can cause serious damage to the traction motors, drivers, lift arms and bucket. Enter the pile slowly.

Loader Operation

Safety

The safe operation of Komatsu equipment is always the number one priority. The operator must be familiar with machine controls and comfortable operating the machine. A competent operator is an operator who has received proper training and can safely **AND** efficiently operate the machine. All operators must be able to focus on the task to be completed. The operator must be familiar with all emergency features and procedures of the Komatsu machines. Safety is a behavior, not an excuse.

Reviewing Loader History

In years past, it was common practice to spot steering wheel equipped trucks at 45 degree angles. The idea was to fill the bucket, then turn the steering wheel a turn and a half to the right while backing up. An operator would travel in reverse a turn and a half of the front left wheel. This would put the loader some distance from the truck, but it was in a safe place to let go of the steering wheel, change directions, and proceed to the truck to dump the bucket.

With Komatsu advanced dual joystick design, this is no longer an issue because the operator never loses contact with any of the machine controls, which benefits the operator by greatly decreasing the amount of travel to and from the dig face to the truck.

Mechanical Lock

- Mechanical loaders do this in an attempt to keep the machine as straight as possible. Due to drivelines and transmissions, all 4 tires are connected.

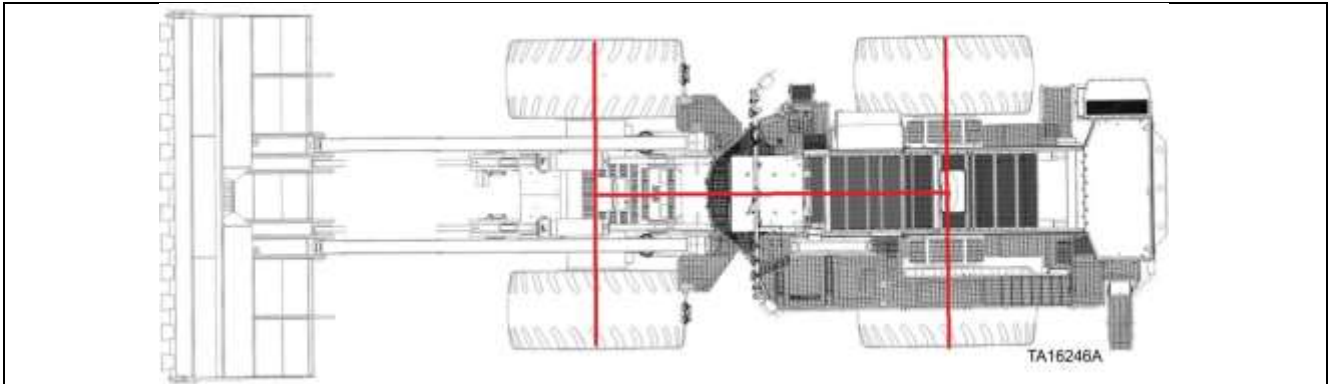

Mechanical Bind Articulating

- When a mechanical loader is articulated, the inside two tires turn less than the outside two tires.

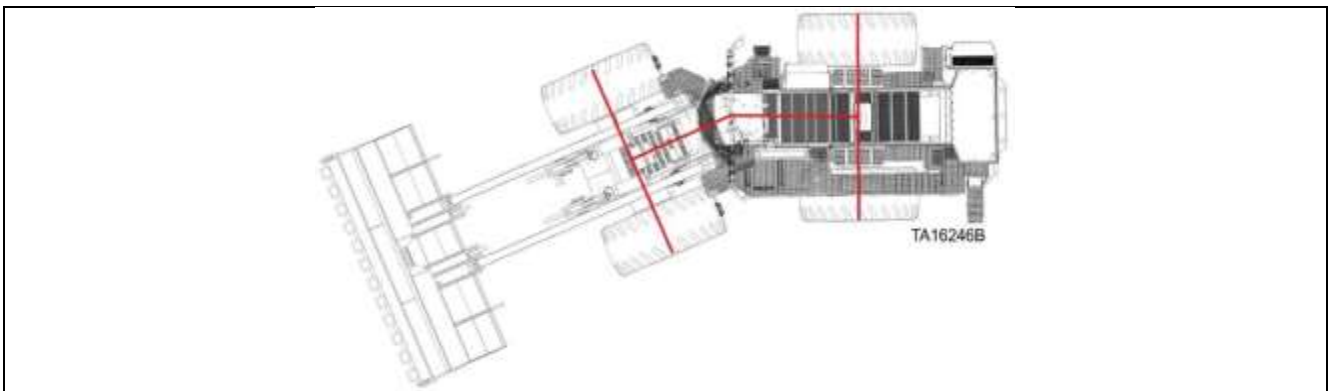

Mechanical Disadvantage

- An articulated mechanical loader can lead to tire scrubbing, torque converter damage, transmission damage, and so forth.

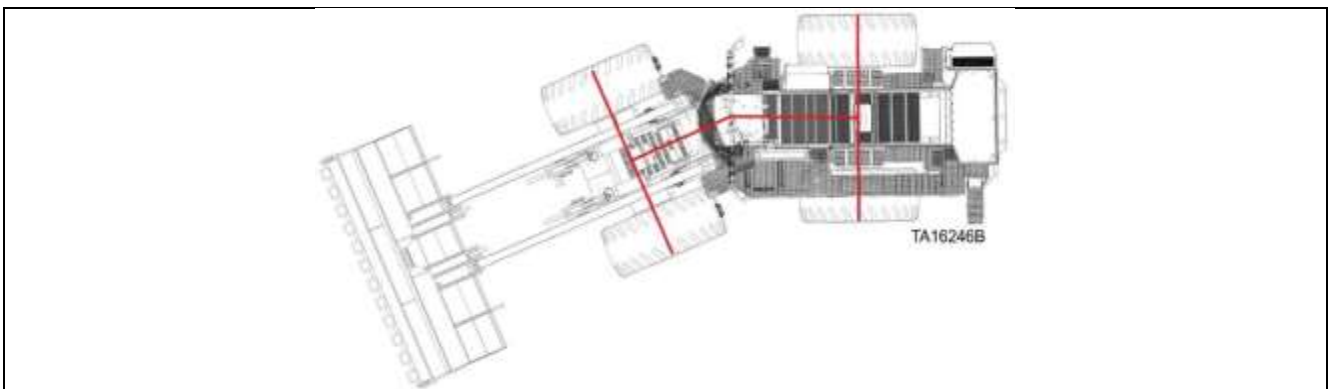

Electric Advantage

- Electric drive loaders have 4 wheel independent drive, thus eliminating many mechanical concerns.

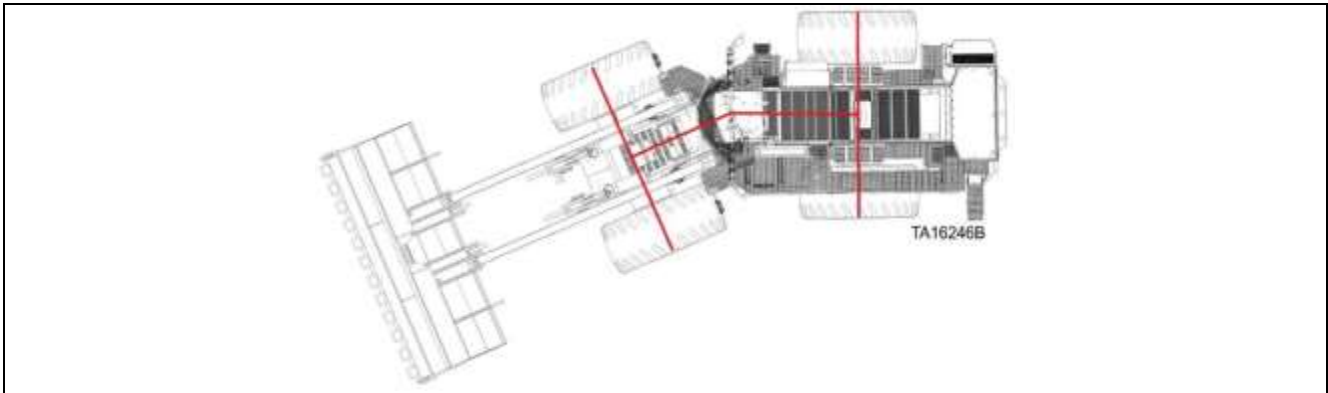

Electric Drive, Making Efficiencies

- Because of the electric drive, Komatsu electric drive surface loaders can articulate without those mechanical concerns. Therefore, eliminating the need to continue spotting trucks at 45 degrees. By eliminating 45 degree truck spotting, the distance traveled from the dig face to the truck, and back to the dig face can be reduced. This decreases cycle times dramatically, reduces wear on the machine, and allows the machine to work on a much smaller footprint.

Placing Trucks

Ideally, trucks should be spotted at 70 to 90 degrees to the dig face. This will ensure the loader doesn't dig behind the truck and promotes keeping the machine straight while digging.

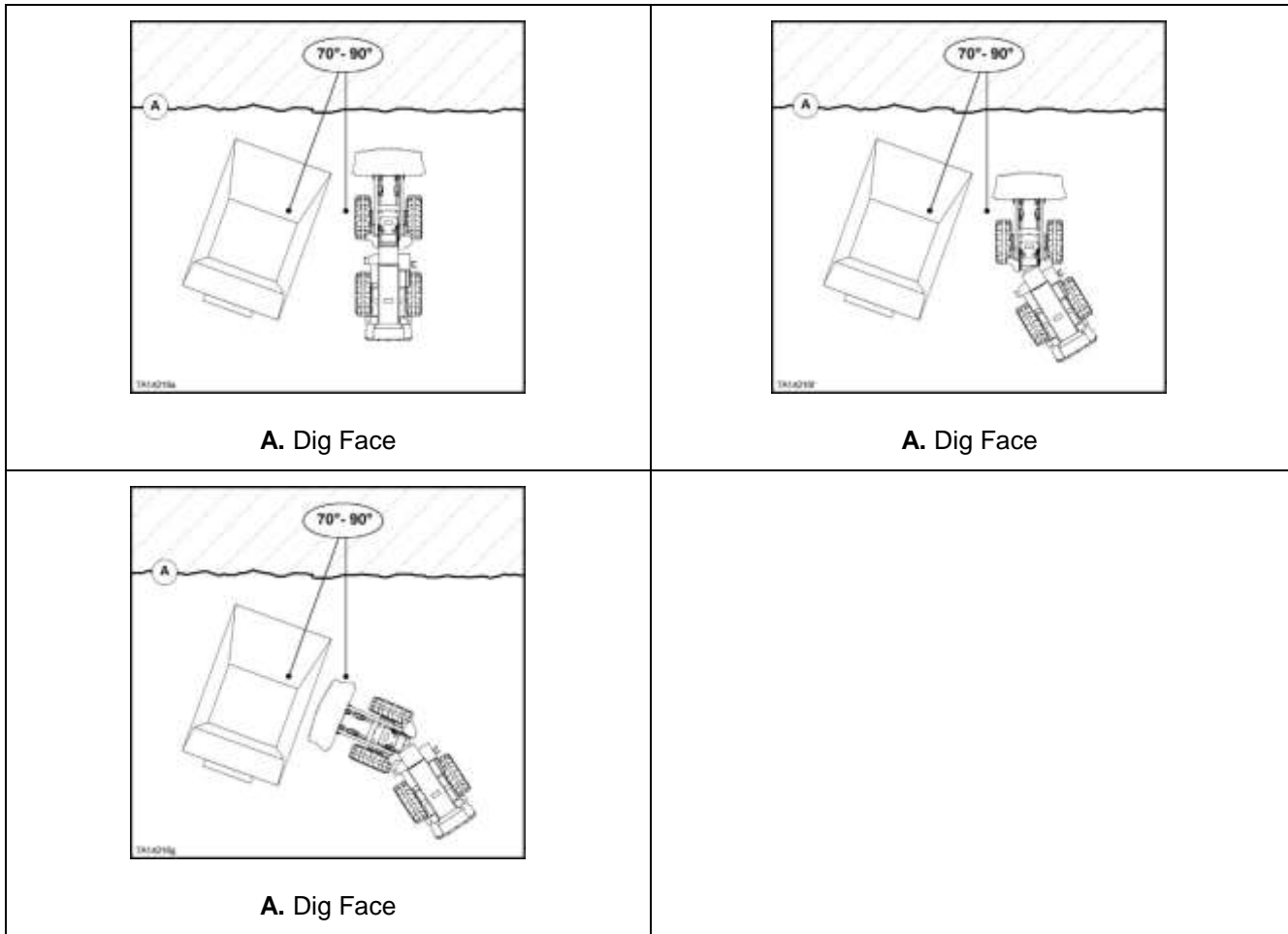

Figure 55. Square work line truck placement

Becoming Efficient

The whole idea is to become efficient. Consistent repeatability creates efficiency. Once an operator gets used to staying close to the truck, always working from right to left, and loading the left side of the truck, the truck transitioning times will improve dramatically as well.



Creating Savings

Savings can occur by best practices when using the machine. Some savings can result because of the following.

Changing the angle of truck spotting

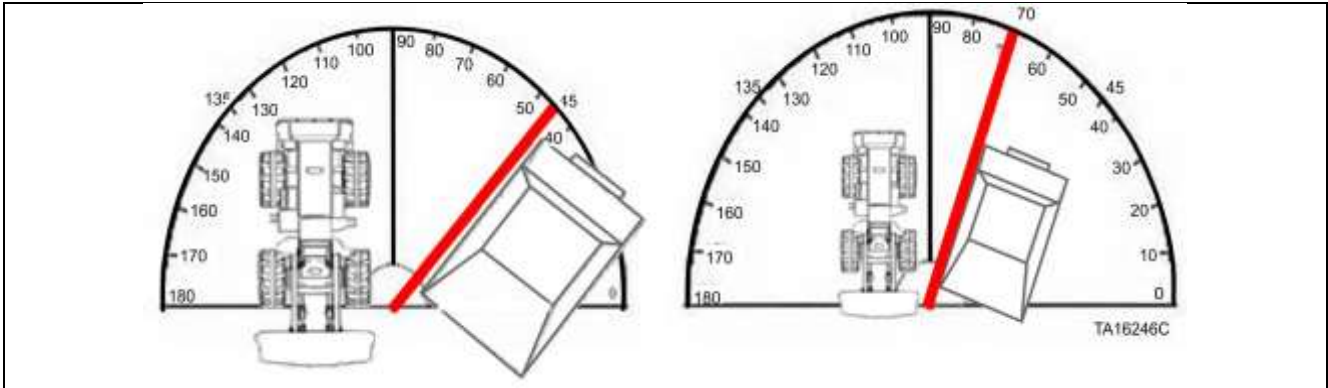

Travel distance is greatly reduced.

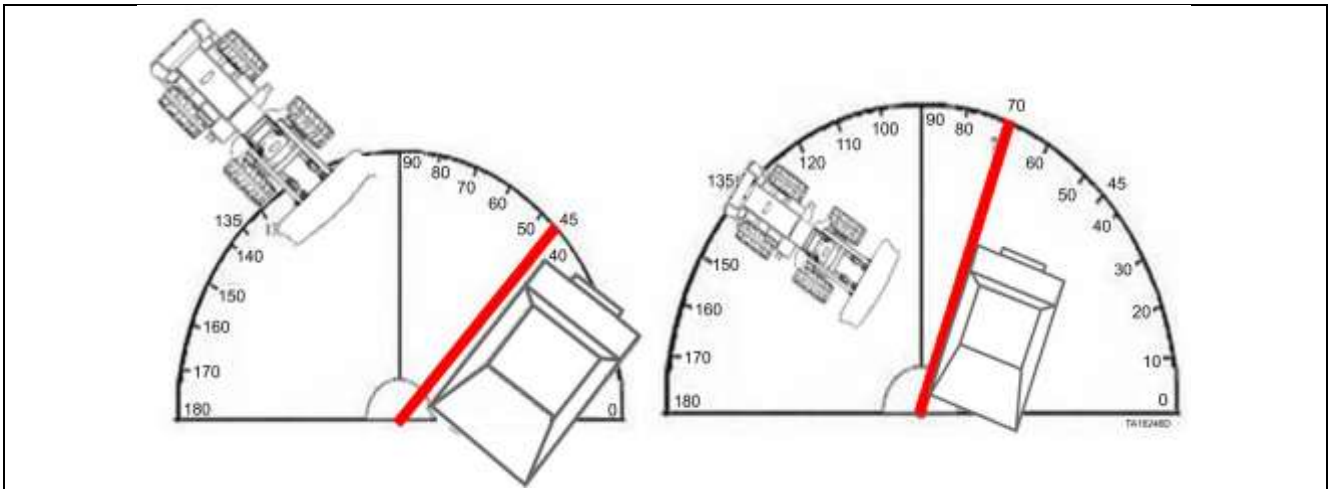

Cycle time is reduced.

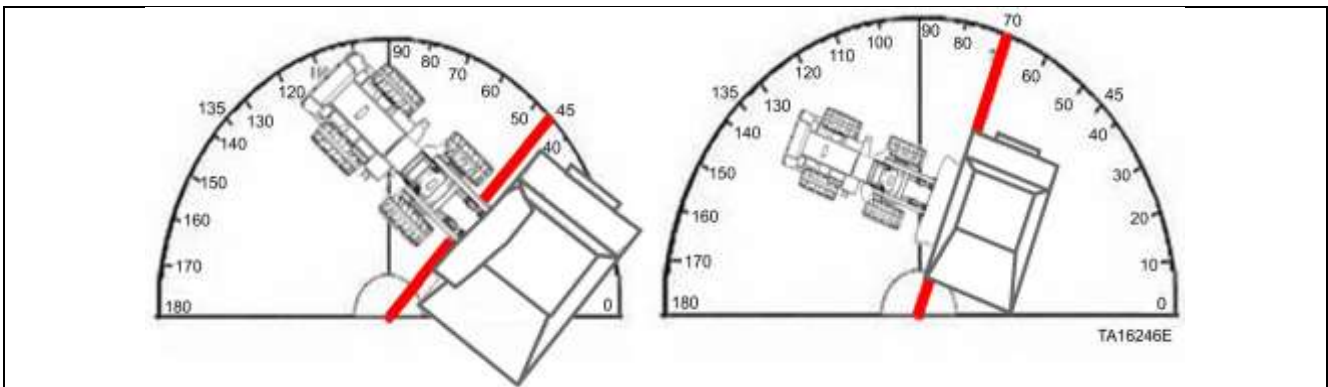

Improving Cycle Time

Get as close to the truck as comfortably possible



Try to keep the bucket as close to the truck as possible



The machine should be fully articulated left, when dumping in the truck



By staying articulated when leaving, the bucket will line up to dig



Make sure the teeth clear the bed



Stay articulated until the bucket is clear of the truck



Use the "Float" button for faster return to dig



Get square to the dig face and then straighten the machine.



Fill bucket and repeat.



Controlling Traffic

Pit traffic should enter the loader's work area on the left side. However, there are special occasions where this is not always applicable. The loader operator should spot trucks on the loader's left side. By always loading to the left side of the loader, traffic has a set pattern and traffic flow remains optimum. When a loader operator continually switches from right-side loading to left-side loading, traffic becomes confused and disorientated and time delays will occur between trucks. Consistency is the key factor in controlling traffic. As the loaded truck leaves the loader, the next truck waiting should follow the loaded truck to begin placement of the truck. When timed correctly, the truck spotting to get loaded, should be backing under the loaders bucket just as the loader reaches his spotting target. Loader operators should **ALWAYS** be aware of environmental surroundings. Keeping an eye on the walls and slopes and applying caution where needed is absolutely necessary. Common sense should play a vital role in every operator's day to day job performance. Never put yourself or others into an unsafe situation.

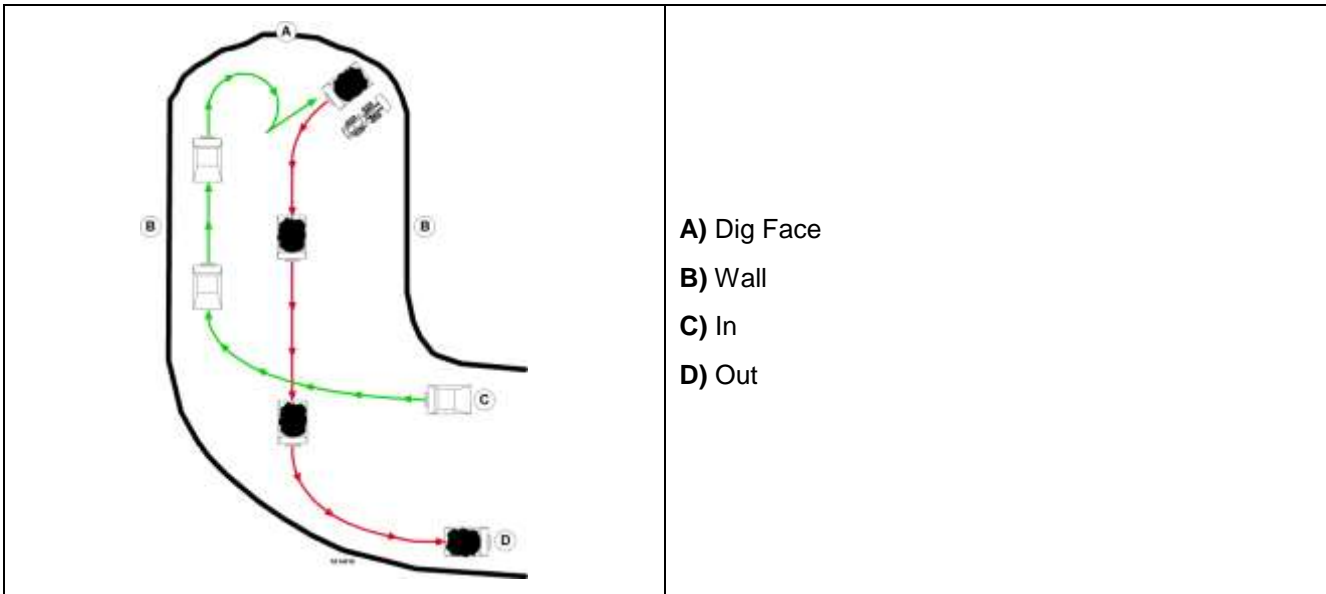

Figure 56. Truck flow (right hand truck)

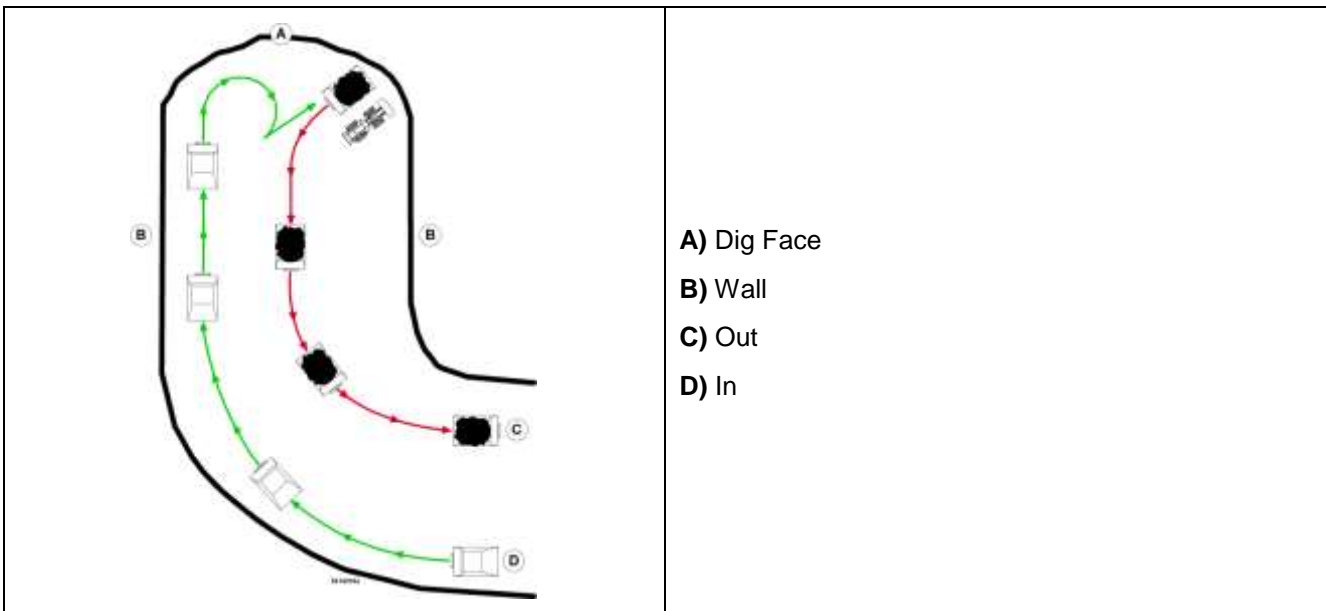

Figure 57. Truck flow (left hand truck)

Digging Theories

There are many digging theories that have been utilized and institutionalized into protocol. The simple fact is, every operator will develop their own style for different scenarios. Too many variables are encountered throughout a day such that there is no perfect theory. However, some have advantages over others.

The most common is the practice of keeping a square dig face. One inherent problem with this theory is that while digging on the left side and right side, uneven stress to the lift arms is added due to the resistance of the dig face as well as the wall. This theory of digging also leads to off side loading of trucks and breaks any consistency or rhythm of the pit traffic. Straight dig faces are difficult to keep the corners. Loaders and trucks are forced to be parallel to high wall or dig face. It puts operators directly under the high wall or spoil pile that could have catastrophic results in the event of a wall collapse or slough.

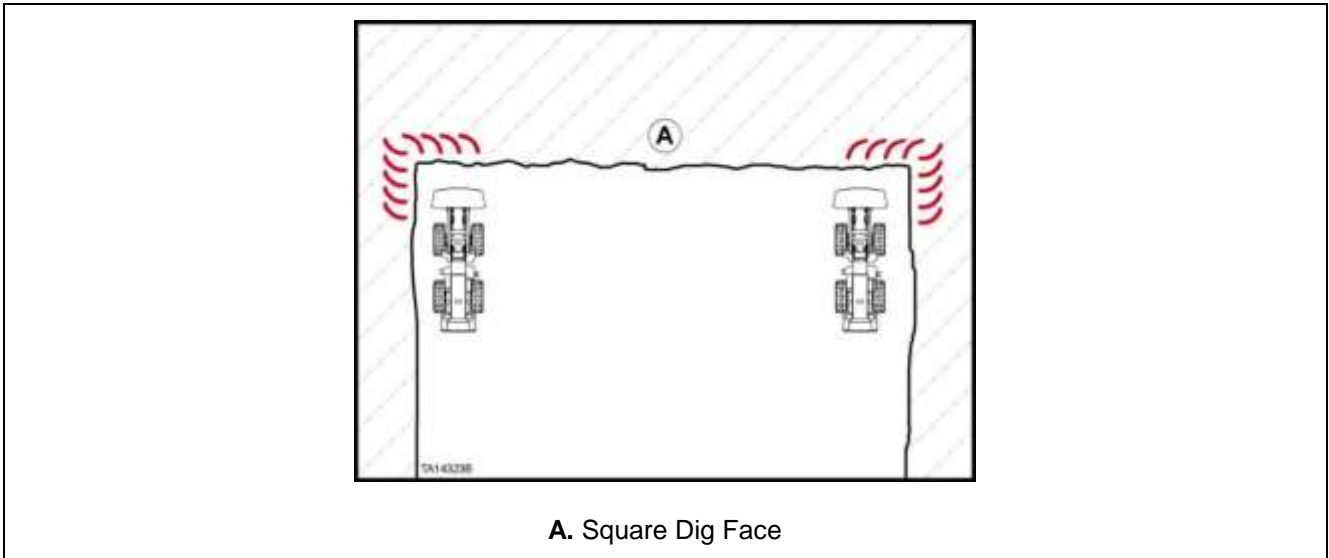

Figure 58. Square dig face

Circular digging addresses these issues and allows the pit traffic to remain constant and keeps operators from paralleling high walls and spoil piles. Circular digging also allows machines to work in small work areas by spreading the dig face into a more user friendly arc.

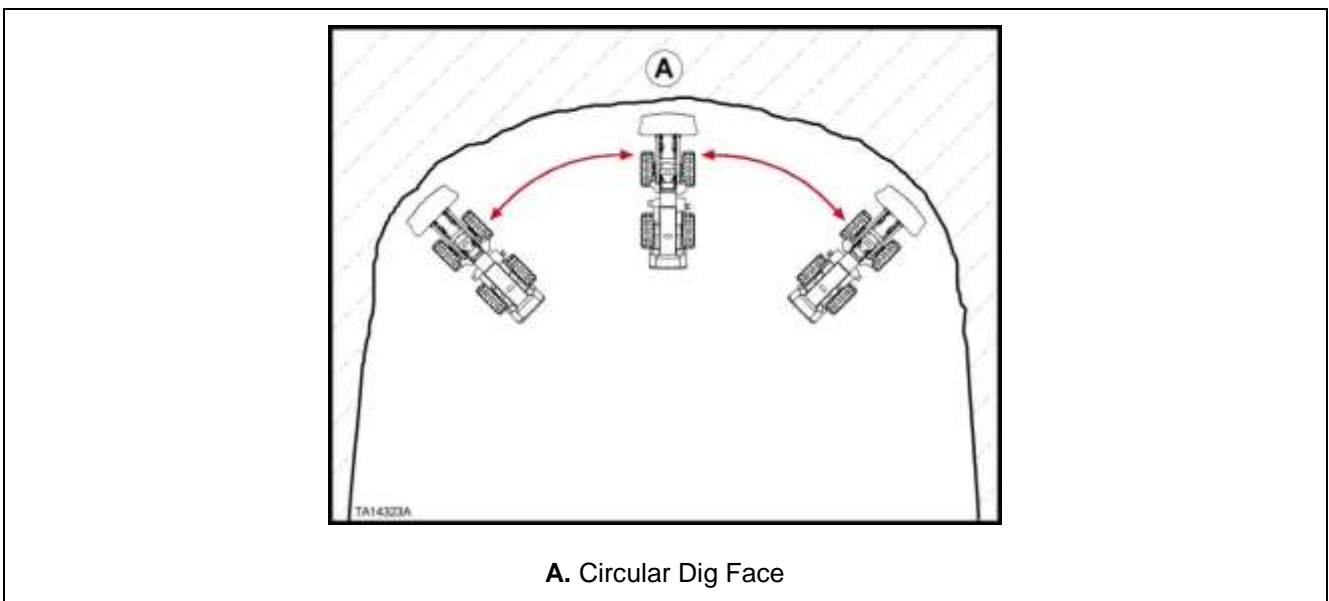

Figure 59. Circular dig face

CAUTION

Equipment damage is possible if operating the machine too close to the bank or high wall. Do not operate the machine parallel, and close to the bank or high wall. Material can fall, damaging equipment. Always leave enough room between the bank or high wall and the machine to move to safety should material fall from the bank or high wall or if the bank or high wall collapses. Failure to leave enough room between the machine and the bank or high wall can cause crush hazards resulting equipment damage.

Do not corner dig with the bucket. Serious equipment damage is possible.



Figure 60. Do not corner dig

⚠ WARNING

Crush hazards exist if operating the machine too close to the bank or high wall. Do not operate the machine parallel, and close to the bank or high wall. Material can fall, crushing personnel. Always leave enough room between the bank or high wall and the machine to move to safety should material fall from the bank or high wall or if the bank or high wall collapses. Failure to leave enough room between the machine and the bank or high wall can cause crush hazards resulting in serious injury or death.

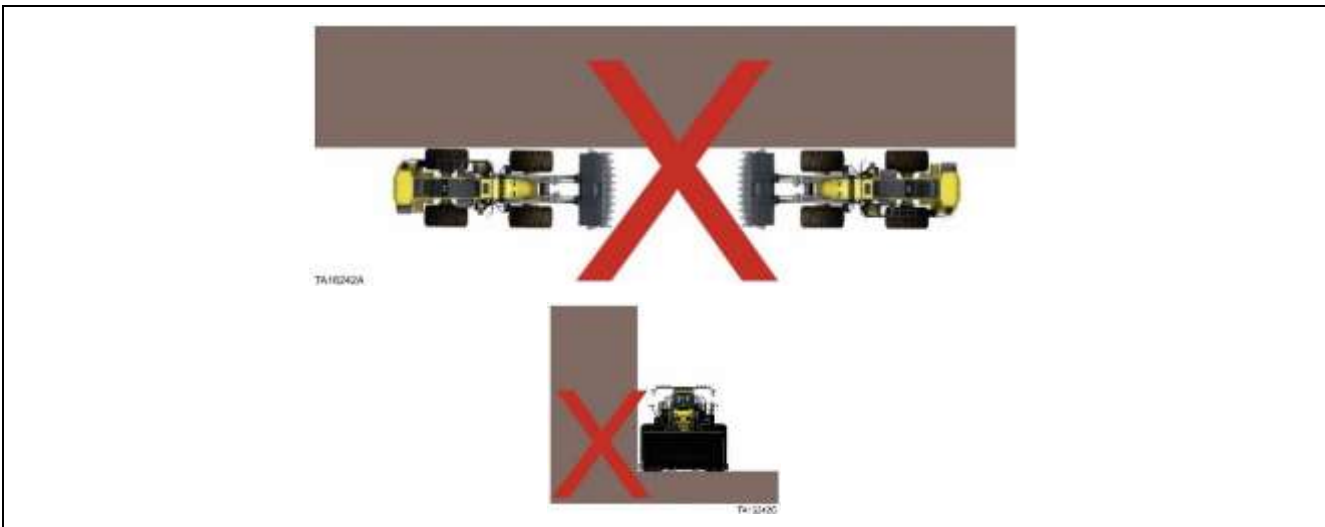

Figure 61. Do not operate close and sideways to the bank (or highwall)

Managing the Dig Face

What is the optimum dig face height? As high as can be safely work under. 20 feet (6 meters) was the standard for years. As the equipment gets bigger, so do the dig faces. 60 foot (18 meters) is not unheard of in some mines. If its full of very large, round boulders, it is better to error on the side of safety. Do not operate the machine so close to the dig face as to endanger the operator or to damage the machine with falling rocks or material.

Controlling the Dig Face

The idea is to stay at one location in the dig face to create an avalanche to feed the loader. Once that “rock slide” begins to fall, the dig face becomes active and does 50% of the work. This is the goal. Once it starts falling it is time to start moving one truck width to the left. Stay disciplined and leave that area that’s falling alone. It will help on the next round. Once the next area is falling, move to the left another truck width. Repeat across the dig face. When the end is reached, start back where the process was started and all that material that has been falling will act like a natural feeder.

Operation

Loading trucks is essentially repeating six steps;

1. Digging (filling the bucket)
2. Hoisting the bucket
3. Traveling to Destination (Truck, Hopper, etc.)
4. Dumping the Bucket
5. Lowering the Bucket (Float)
6. Travel back to Dig Face

Operators new to Komatsu equipment should focus on completing each step flawlessly and then start to blend step one with step two, step two with step three and so on. Form and smoothness should be the goals as speed will follow. The Loader should never stop; thus becoming one flowing movement without jerkiness and bouncing.

Using the Bucket Auto Level



Figure 62. Use the bucket auto level on overhead keypad (Item#2)

Bucket Auto Level



The Auto Level Switch is a two-position momentary pushbutton switch. This switch enables or disables the auto-leveling feature of the bucket.

When the switch is pressed, the auto-leveling feature is enabled. The left LED will illuminate.

Pressing the switch a second time disables the auto-level feature and the LED goes out.

If the auto-leveling feature is switched from disabled to enabled, and the button is pressed and held for a minimum of 2 seconds, while the lift arms are below 0°, the current angle of the bucket is recorded as the bucket angle to which to auto level.

Sometimes the bucket auto level will be reset a few hundred times during a shift. Conditions are always changing.

- If the digging gets hard, change the bucket angle so the teeth are digging deeper.
- If holes are being dug, change the bucket angle so the teeth are not digging as deep.

Some operators like to let the bucket land close, then adjust it every single time manually. This can be cumbersome as the bucket will not hit the same exact spot every time. The floor will resemble that. However, the machine will land in the same exact spot every time, and the floor will resemble that.

Digging

When digging, always engage the bucket straight with the bank. When approaching the bank, the bucket should be approximately 1" off the ground, and the loader ground speed should be about 4 MPH. As the bucket engages the bank, begin to curl and lift the bucket. This simultaneous action not only utilizes the hydraulic strength of the lift and curl cylinders, but also takes advantage of the forward motion of the loader. The bucket section of the hydraulic system has priority over the hoist so when the bucket is curled, the hoist will stop or slow noticeably. Use the speed control pedal to provide sufficient power for proper penetration, but DO NOT allow the tires to spin.

Steps to complete a cycle

1. Approach the dig face around 4 mph.
2. Bucket set to just grazing the floor with the teeth.
3. Slightly curl the bucket when propulsion into the face slows.
4. Then hoist while maintaining bucket contact by using the speed control pedal.
5. Once hoist slows, curl back a little more while maintaining bucket contact in the dig face.
6. Ideally, the machine will break out of the dig face with a full bucket when hoist is just above being directly in line with the cab.



Figure 63. Engage the bucket straight with the bank

The bucket should always be filled low in the bank. The bucket should be full, not over-full. The spill guard on the back of the bucket is to protect from spillage off the back of the bucket while in forward motion. If this area is already full, material has no place to go except over the back of the bucket, possibly damaging the machine or causing severe injury or death to the operator.

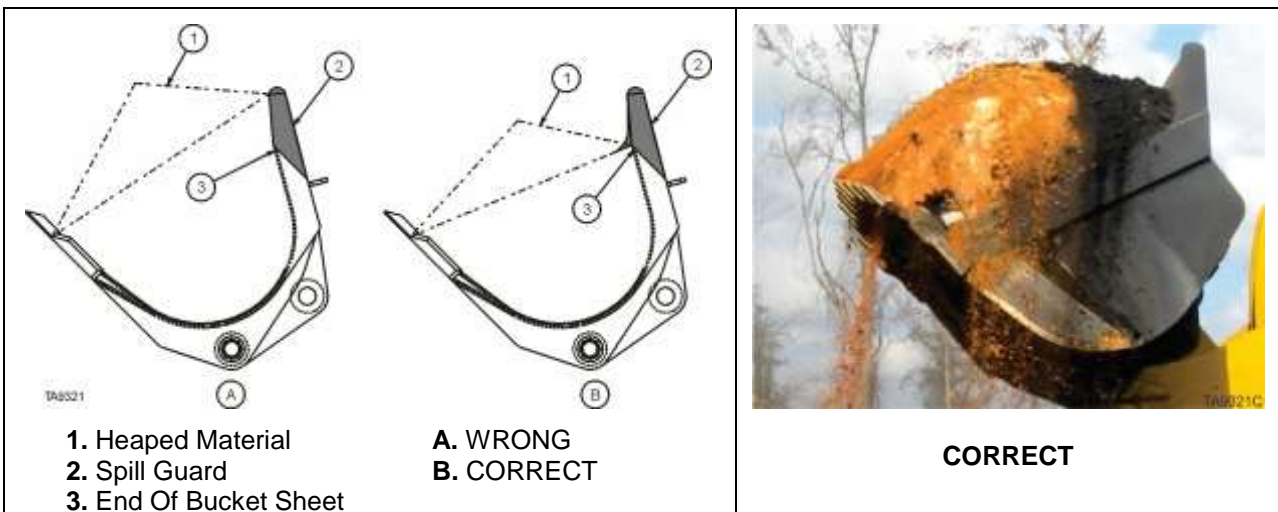

Figure 64. Bucket loading

Recognizing the Signs of Bucket Position

When backing away from the dig face, look at the marks the teeth left in the floor. Marks on the floor indicate desirable and undesirable bucket and teeth position.



Bucket teeth too high

Heel plate marks are visible.

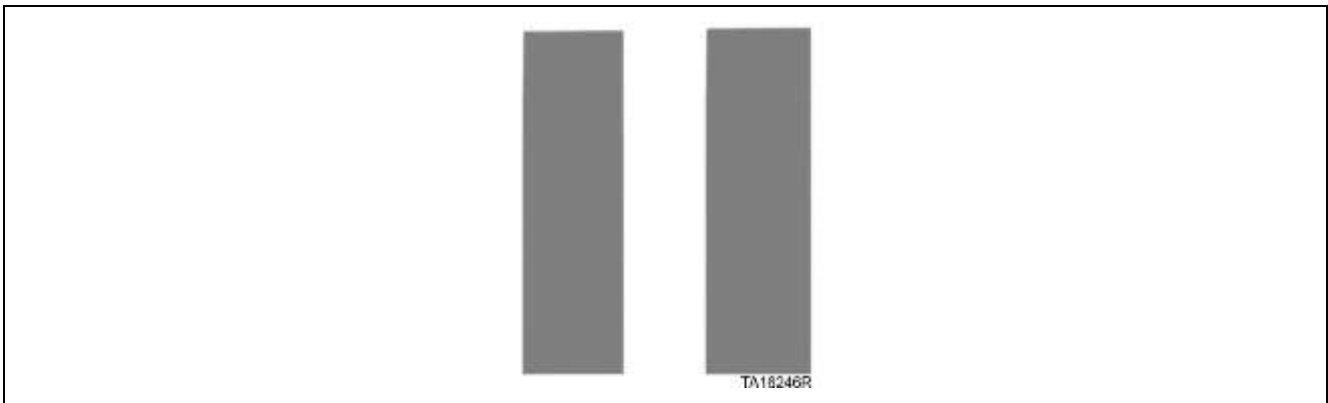

Bucket teeth too low

Deep ridges are visible.

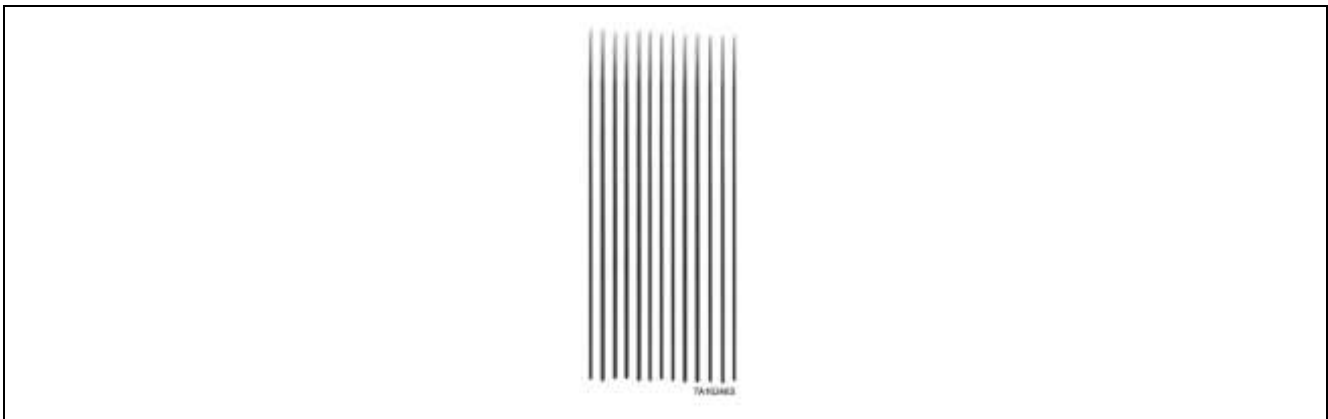

Ideal

Slight ridges are visible, but the tires flatten them out

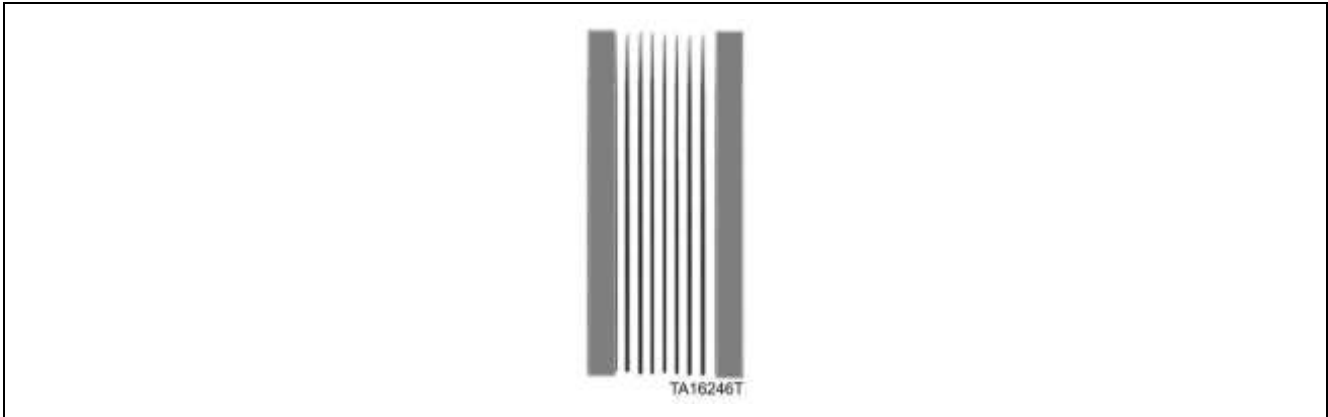

NOTICE

Every floor is different. Find the right combination for each application

Hoisting and Traveling to the Truck

These two “steps” occur simultaneously in efficient loader operation. Once the bucket is full, begin to back away from the loading face. As soon as the bucket is no longer engaged in the material, begin hoisting while continuing to back out. Once backed out far enough, the machine should be brought to a smooth stop, shifted to forward and forward motion resumed while the hoisting motion continues. Approach the truck slowly, making sure the bucket is high enough to prevent contact of any kind between the loader bucket or arms and the side rails on the truck. With the loader hoisting from the time the full bucket is obtained, the operator should be in place at the truck and ready to dump as the bucket reaches the proper height. This requires coordination and practice to achieve man and machine performing as one fluid movement.

Dumping the Bucket

Once the bucket is over the truck bed, begin to dump the load. Dump the first load into the truck slowly to prevent damage to the truck beds liners. This first bucket will act as bedding for the following buckets. Depending on the Loader to Truck match, it may be necessary to level the bucket before pulling away from the truck to ensure the bucket will not “rake” the bed rails of the truck. Do not allow any contact between the loader and the truck.

Lowering the Bucket and Traveling to the Dig Face

Once the loader has backed away from the truck, begin lowering the bucket by selecting “back to dig”. This allows the bucket to lower rapidly, but not in a free fall. The auto level feature will automatically level the bucket for the operator. When timed properly, the loader bucket should be close enough to the ground that hoist is ready to be applied. This takes practice and should not be expected with new operators. Note, if spillage occurs, take the time to clean it while preparing to get the next bucket. Do not run over spillage as tire damage will occur.

Pit Floor Maintenance

Experienced loader operators pride themselves on the floor they keep. It is easy to judge a loader operators' skill simply by looking at the floor they keep.

A simple way to keep a floor on grade and free of debris is to start on one side of the work area and utilize a sweeping motion with the loader bucket. This will keep windrows to the outside of the arc. While the inside of the bucket will follow the grade of the previous pass, the outside edge of the bucket will cut and fill as needed. It may take several passes to fix a bad floor and with practice, can be accomplished while still loading trucks.

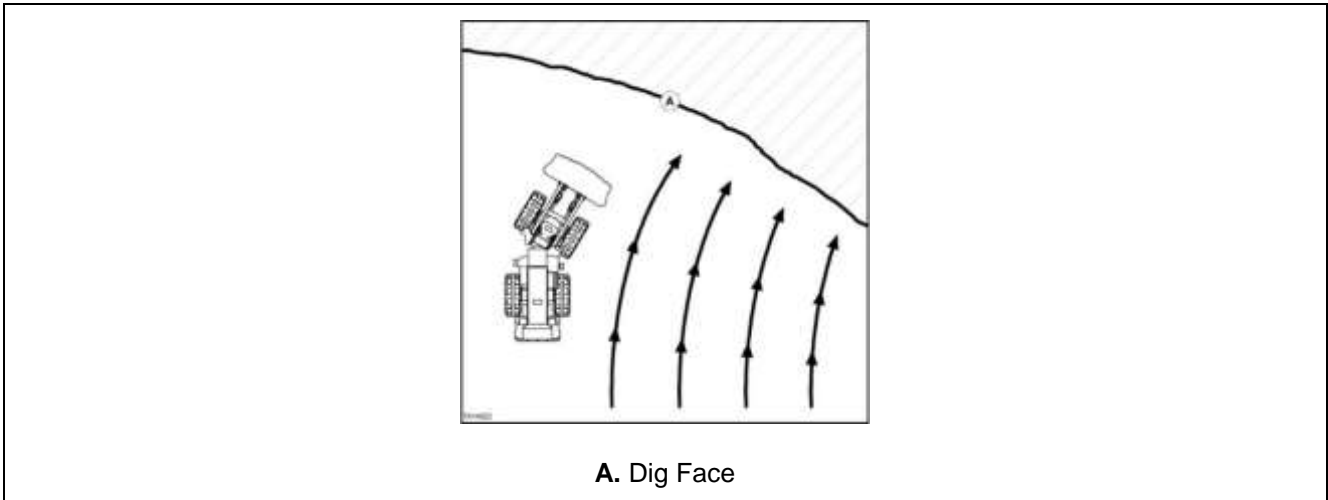

Figure 65. Pit floor maintenance

Maintaining Grade

| | |
|--|---|
| | <p>It is easier to keep grade at the dig face, not 10' or 20' away.</p> |
| | <p>Don't be afraid to get aggressive.</p> |

Recognizing Bucket Loads

Four icons are presented to the operator after the bucket loading process.

If the bucket is under loaded, fill the bucket more.



Figure 66. Bucket under loaded.



Figure 67. Normal capacity, Green



Figure 68. Overload, Yellow



Figure 69. Critical Overload, Red

Responding to Bucket Overloads

- If a “yellow warning” overload occurs, proceed with caution and dump normally.
 - There is a misconception that getting an overload yellow warning is a bad thing. It is actually good, as it shows that the machine is being used to capacity.
- If a “red warning” critical overload occurs, simply take it back to the dig face and dump it out.
 - Red warning critical overloads happen, but not very often.

The operator should watch the hoisting of the day's first bucket load when approaching the truck to be loaded. If the bucket stops before it reaches the normal top (refer to HOISTING THE LOAD, below) or stops before rising past the required dump height of the sides of the truck, the bucket is overloaded. Overloading is harmful to the loader.

NOTICE

If the bucket is loaded to 120% of rated capacity hoisting action is inhibited, the yellow light will illuminate, the audible alarm will sound and the text screen indicating bucket overload will appear on the touch screen. The audible alarm can be silenced and the text message removed from the screen by pressing the Acknowledge button. However, the yellow light will continue to illuminate.

If overloading occurs and the bucket stops, the operator must push the Hoist Joystick forward to lower the lift arms and use the Bucket Control Switch or move the Hoist Joystick to the right to dump the bucket.

On the next cycle, the operator must not load as much material into the bucket as was in the previous load. If this loaded bucket goes to the normal top without stopping, it is not critically overloaded. Properly loaded buckets (not overloaded) reflect good work practice by the operator and results in reliable machine performance.

The amount of material in the bucket can be monitored by checking the production data screen on the touch screen.

NOTICE

Should an overload cause the machine to tip forward while hoisting or transporting a load, DO NOT PANIC! Do not articulate the machine. Lower the bucket to the ground and the machine will stabilize.

All lift capacities are based on the criteria of the machine being level, on firm supporting ground. When the machine is operated in conditions that deviate from these criteria (e.g. on soft or uneven ground, on slope or when subject to slide loads), these conditions shall be taken into account by the operator.

The bucket for the loader is rated as follows.

NOTICE

These ratings are based on ISO standards.

DO NOT load material onto the spill guard as the bucket will be overloaded and this could damage the loader and result in injury to the operator. The bucket should be loaded only to the bottom of the spill guard. Refer to text titled "Digging" as described previously in this section.

| Machine | Standard Lift Lbs. | High Lift Lbs. | Super High Lift |
|---------|----------------------------|----------------------------|----------------------------|
| L-1350 | 90,000 lbs. (40,823 kgs.) | 84,000 lbs. (38,102 kgs.) | N/A |
| L-1850 | 120,000 lbs. (54,431 kgs.) | 110,000 lbs. (49,895 kgs.) | N/A |
| L-2350 | 160,000 lbs. (72,574 kgs.) | 150,000 lbs. (68,039 kgs.) | 120,000 lbs. (54,431 kgs.) |

This Page Intentionally Left Blank

Operator's Daily or Pre-Shift Walk-Around Inspection and Service

The "Operator's Walk-around" provides a list of items to be checked/inspected before every shift. This information is provided in a checklist form that can be filled for record keeping purposes. A condensed checklist is provided at the end of the document and can be used once the operator becomes familiar with all areas being checked.

NOTICE

The left or right side of the machine is determined as when sitting in the operator seat.

Walk-around inspection starts at the left rear planetary drive and progresses clockwise around the machine and progresses to the cab. Refer to illustration "Position Chart" for position locations. Numbers show the general location of referenced components. Walk-around inspection requires hardhat, safety glasses, a flashlight, and any other safety equipment required by your work location.

A checklist is provided at the end of this section for use in the operator walk around.

Safety Preparations

WARNING

Crush hazards exist if the machine is started or moves while inspections are being conducted. Place bucket flat and level on the ground. Lock out the machine's starting capability before performing any inspection. Follow all lockout tag out rules, local rules, and local regulations to return the machine back to service. Failure to follow all lockout tag out rules, local rules, and local regulations for returning the machine back into operating condition could cause unexpected equipment component movement for personnel in the area, resulting in serious injury or death.

WARNING

Crush hazard exists if relieving hydraulic pressure from the hoist and bucket circuit. Before servicing or repairing anything pertaining to the hydraulic system, the pressure should always be relieved from the hoist and bucket hydraulic circuits. The area must be cleared of all personnel before relieving hydraulic pressure from the hoist and bucket circuit. Relieving pressure by using the "MANUAL BLEED VALVE ASSEMBLY" (Refer to Section 04 in the Service Manual), can cause the lift arms and bucket to descend rapidly. The machine must NOT be running when using the manual bleed valve assembly. Failure to clear the area of all personnel can cause a crush hazard that could result in serious injury or death.

WARNING

Electrical shock hazard exists when the generator is primed and operating and until 5 minutes after the machine is shut down. High voltage is present on the dynamic grids when the generator is primed and operating. Do not touch electrical connections or braking grids until at least 5 minutes after the machine is shut down and ignition key is off. Touching electrical connections or braking grids can cause electrical shock resulting in serious injury or death.

- a. Stop the wheel loader on flat level ground.

- b. Place bucket flat and on level ground.
- c. Set the parking brakes.
- d. Shut off the engine.
- e. Turn on maintenance light switch located at left rear of machine in Control Switch Box Assembly.
- f. Lock out the machine's starting capability before performing any inspections.
- g. Turn the battery and engine isolation switches to the off position and install locks on the battery isolation switch.

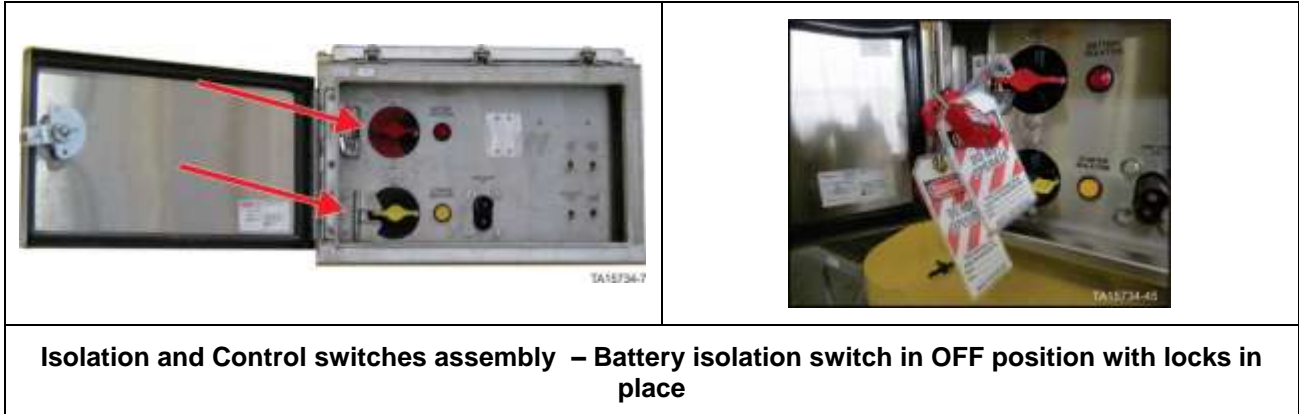

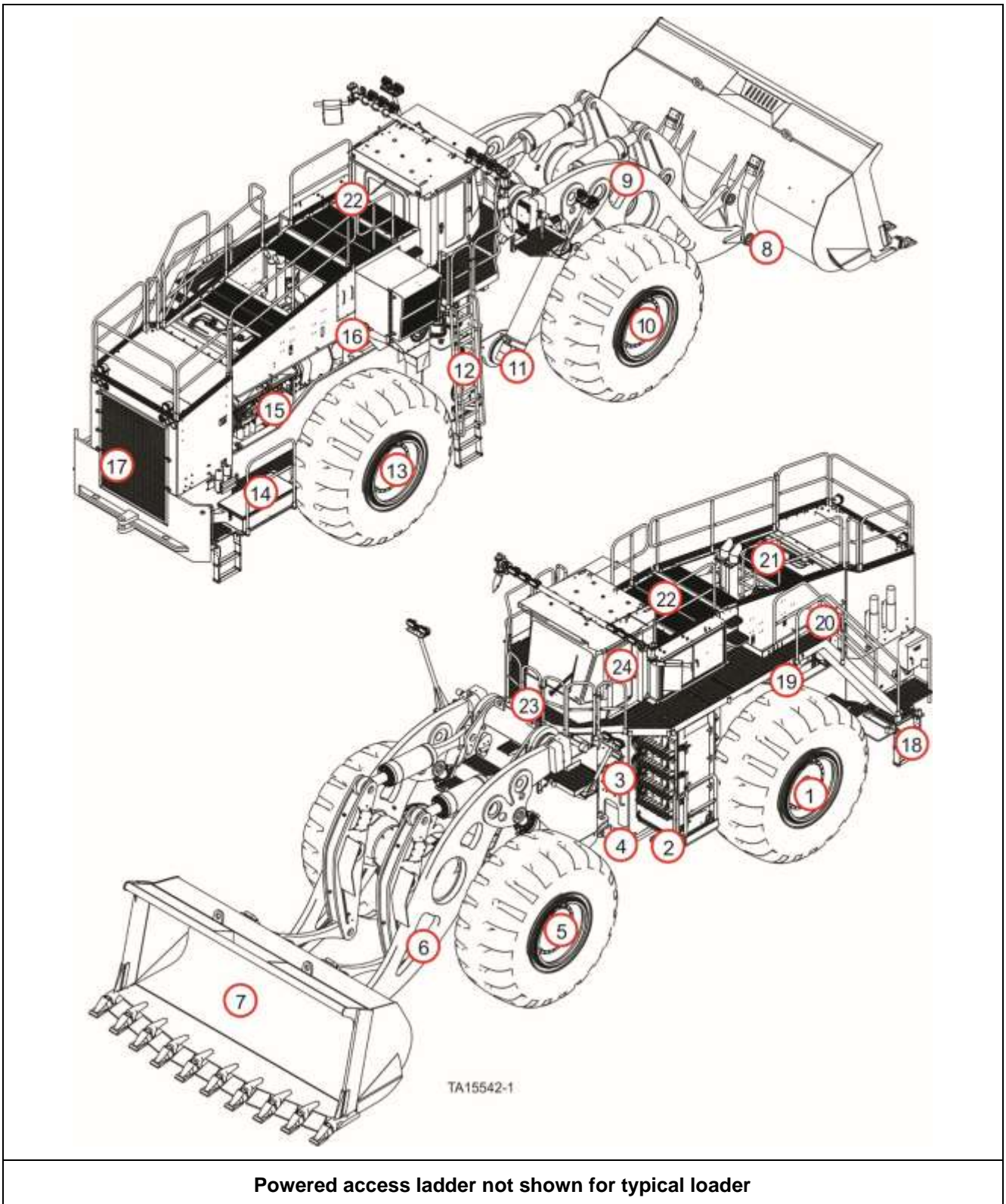

Figure 70. Position chart for PM procedures (typical loader)

This Page Intentionally Left Blank

| Chart Position | Operator Daily or Pre-Shift Walk Around Item to check/inspect | | Checked | Service Required |
|----------------|---|--|---------|------------------|
| 1 | Left rear planetary drive and wheel/tire. | | | |
| | a. | Planetary drive cover structure bolts loose or missing? | | |
| | b. | Planetary drive oil leaks? | | |
| | c. | Loose or missing wheel retaining bolts? | | |
| | d. | Tire damage? | | |
| | e. | Rim damage? | | |
| | f. | Cooling duct to rear axle in place and secure? | | |
| 2 | Platform and High Voltage cabinet. | | | |
| | a. | Platform clean and secure? | | |
| | b. | Cabinet door latched and sealed? | | |
| 3 | Safety Link properly retained? | | | |
| 3 | Left pivot area, steering cylinders, and stop pad. | | | |
| | a. | Auto lube system functioning properly, a wet look of fresh grease at cylinder rod eyes? | | |
| | b. | Steering filter leaks? | | |
| | c. | Steering cylinder hydraulic leaks? | | |
| | d. | Steering stop pad in good condition and secure? | | |
| | e. | Use remote drain assembly to drain moisture from compressed air system reservoirs inside rear frame. | | |
| | f. | Safety or instructional labels deteriorated, damaged, or missing? | | |
| 3 | Inside rear frame (enter at pivot area). | | | |
| | a. | Oil leaks? | | |
| | b. | Hydraulic Pump Drive Gearbox oil level at specified level? (Check sight gauges on gearbox. If low, locate and repair leak and fill before commencing operation.) | | |
| | c. | Hydraulic Pump Gearbox mounts secure? | | |

| Chart Position | Operator Daily or Pre-Shift Walk Around Item to check/inspect | | Checked | Service Required |
|----------------|--|--|---------|------------------|
| | d. | Any loose bolts? | | |
| | e. | Any flammable liquid, material, or debris? If so, remove before operating machine. | | |
| 3 | Under front frame and rear frame. | | | |
| | a. | Any leaks noted - location - appearance of fluid? | | |
| | Inside front frame (enter at left pivot area): <div style="background-color: #0056b3; color: white; text-align: center; padding: 5px; font-weight: bold; font-size: 1.2em;">NOTICE</div> Turn on Maintenance Lights with switch located at left rear of machine in the Control Switch Box Assembly. | | | |
| | a. | Oil leaks? | | |
| | b. | Grease lines broken, twisted, or kinked? | | |
| | c. | Hoses and wiring undamaged and secure? | | |
| | d. | Cooling ducts and hoses secure? | | |
| | e. | Safety or instructional labels deteriorated, damaged, or missing? | | |
| f. | Any flammable liquid, material, or debris? If so, remove before operating machine. | | | |
| 4 | Left hoist cylinder | | | |
| | a. | Ball cap retaining bolts loose or missing? | | |
| | b. | Grease line broken, twisted, or kinked? | | |
| | c. | Auto lube system functioning properly; a wet look of fresh grease at ball cap? | | |
| | d. | Hydraulic leaks? | | |
| e. | Safety or instructional labels deteriorated, damaged, or missing? | | | |
| 5 | Left front planetary drive and wheel/tire. | | | |
| | a. | Planetary drive cover structure bolts loose or missing? | | |
| | b. | Planetary drive oil leaks? | | |
| | c. | Loose or missing wheel retaining bolts? | | |
| d. | Tire damage? | | | |
| 6 | Left side Lift arms (lower) | | | |
| | a. | Grease lines broken, twisted, or kinked? | | |
| b. | Auto lube system functioning properly, a wet look of fresh grease at lube points? | | | |

| Chart Position | Operator Daily or Pre-Shift Walk Around Item to check/inspect | | Checked | Service Required |
|----------------|---|---|---------|------------------|
| | c. | Visible cracks in lift arms? DO NOT OPERATE MACHINE IF CRACKS ARE PRESENT! | | |
| | | d. Rim damage? | | |
| | | e. Safety or instructional labels deteriorated, damaged, or missing? | | |
| 6 | Left side, bellcrank, area and rear of bucket. | | | |
| | a. | Bucket retaining pins intact? | | |
| | b. | Rollback and dump stop pads in good condition? | | |
| | c. | Bellcrank pivot bolts loose or missing? | | |
| | d. | Grease lines broken, twisted, or kinked? | | |
| | e. | Auto lube system functioning properly — a wet look of fresh grease at pin bores? | | |
| | f. | Safety or instructional labels deteriorated, damaged, or missing? (Check front axle). | | |
| 7 | Bucket | | | |
| | a. | Visible Cracks? | | |
| | b. | Damage? | | |
| | c. | Missing, damaged or loose teeth, or lip coverage parts? | | |
| 8 | Right side, bellcrank area, and rear of bucket. | | | |
| | a. | Bucket retaining pins intact? | | |
| | b. | Rollback and dump stop pads in good condition? | | |
| | c. | Bellcrank pivot bolts loose or missing? | | |
| | d. | Grease lines broken, twisted or kinked? | | |
| | e. | Auto lube system functioning properly, a wet look of fresh grease at pin bores? | | |
| | f. | Safety or instructional labels deteriorated, damaged or missing? | | |
| 9 | Right side Lift arms (lower) | | | |
| | a. | Grease lines broken, twisted, or kinked? | | |
| | b. | Auto lube system functioning properly, a wet look of fresh grease at lube points? | | |
| | c. | Visible cracks in lift arms? DO NOT OPERATE MACHINE IF CRACKS ARE PRESENT! | | |
| 10 | Front Axle | | | |
| | a. | Front axle access cover in place and secure? | | |
| | b. | Safety or instructional labels deteriorated, damaged, or missing? | | |
| 10 | Right front planetary drive and wheel/tire. | | | |

| Chart Position | Operator Daily or Pre-Shift Walk Around Item to check/inspect | | Checked | Service Required |
|----------------|---|--|---------|------------------|
| | a. | Planetary drive cover structure bolts loose or missing? | | |
| | b. | Planetary drive oil leaks? | | |
| | c. | Loose or missing wheel retaining bolts? | | |
| | d. | Planetary drive to axle retaining bolts loose or missing? | | |
| | e. | Tire damage? | | |
| | f. | Rim damage? | | |
| 11 | Right hoist cylinder. | | | |
| | a. | Ball cap retaining bolts loose or missing? | | |
| | b. | Grease line broken, twisted, or kinked? | | |
| | c. | Auto lube system functioning properly, a wet look of fresh grease at ball cap? | | |
| | d. | Hydraulic leaks? | | |
| | e. | Steering position transducer intact? | | |
| | f. | Safety or instructional labels deteriorated, damaged, or missing? | | |
| 12 | Hydraulic reservoir - climb ladder right side. | | | |
| | a. | Ladder clean and secure? | | |
| | b. | Oil level in sight glass to spec level? (approximately ¾ full in sight glass) | | |
| | c. | Reservoir mounts intact? | | |
| | d. | Filler cap in place and tight? | | |
| | e. | Hydraulic leaks? | | |
| | f. | Manual air release valve in closed position? | | |
| | g. | Automatic air (release) valve button pushed IN to closed position? | | |
| | h. | Check KLENZ™ filtration system air intake for a buildup of coal dust or dirt. | | |
| 13 | Right rear planetary drive and wheel/tire. | | | |
| | a. | Planetary drive cover structure bolts loose or missing? | | |
| | b. | Planetary drive oil leaks? | | |
| | c. | Loose or missing wheel retaining bolts? | | |
| | d. | Tire damage? | | |
| | e. | Rim damage? | | |
| 14 | Right rear of machine. | | | |
| | a. | Battery box intact? | | |

| Chart Position | Operator Daily or Pre-Shift Walk Around Item to check/inspect | | Checked | Service Required | |
|----------------|---|---|--|------------------|--|
| | b. | Check auxiliary oil cooler (If present) for cleanliness and for hydraulic leaks. | | | |
| 15 / 16 | Engine compartment (right side). | | | | |
| | a. | Coolant leaks at engine, hoses, radiator? | | | |
| | b. | Drive belts in good condition? (If visible without pulling guards) | | | |
| | c. | Fuel leaks? | | | |
| | d. | Engine oil leaks? | | | |
| | e. | Wiring in good condition and secure? | | | |
| | f. | Fan, fan grill, and hood grating in good condition and secure? | | | |
| | g. | Guards in place and secure? | | | |
| | h. | Check engine oil level (if dipstick on this side). | | | |
| | i. | Cooling air duct to generator in place and secure? | | | |
| | j. | Mufflers in good shape and secure? | | | |
| | k. | Fire suppression system bottles, nozzles, and hoses in good condition? (optional) | | | |
| | l. | Anything that might present a fire hazard? | | | |
| | m. | Safety or instructional labels deteriorated, damaged, or missing? | | | |
| n. | Inspect engine air intake tubes and supports: | | Deterioration of rubber or metal. | | |
| | | | Brackets for tightness. | | |
| | | | Hoses secure and against welded lip of tubing. | | |
| 17 | Rear of machine. | | | | |
| | a. | Radiator and hydraulic oil cooler core clean? | | | |
| | b. | Braking grids secure and clean? (DO NOT TOUCH until at least 5 minutes after machine is shut down). | | | |
| | c. | Rear lights and backup alarm in good condition/positioned correctly? | | | |
| 18 | Left rear of machine. | | | | |
| | a. | Fuel reservoir cap secure? | | | |
| | b. | Central Service System in good condition and box cover closed? (optional) | | | |
| | c. | Powered access ladder in good condition (if present). Free of debris or slippery surfaces? | | | |
| | d. | Powered access ladder operating properly? (if present) | | | |
| | e. | Flexible step, clean and in good condition (if present) | | | |
| 19 | Engine compartment (left side). | | | | |
| | a. | Coolant leaks at engine, hoses, and radiator? | | | |
| | b. | Drive belts okay? (if visible - without pulling guards) | | | |

| Chart Position | Operator Daily or Pre-Shift Walk Around Item to check/inspect | | Checked | Service Required | |
|----------------|---|---|--|------------------|--|
| | c. | Fuel leaks? | | | |
| | d. | Engine oil leaks? | | | |
| | e. | Wiring in good shape and secure? | | | |
| | f. | Fan, fan grill, and hood grating in good shape and secure? | | | |
| | g. | Guards in place and secure? | | | |
| | h. | Check engine oil level (if dipstick on this side). | | | |
| | i. | Fire suppression system bottles, nozzles, and hoses intact? (optional) | | | |
| | j. | Anything that might present a fire hazard? | | | |
| | k. | Safety or instructional labels deteriorated, damaged, or missing? | | | |
| | l. | Inspect engine air intake tubes and supports: | Deterioration of rubber or metal. | | |
| | | | Brackets for tightness. | | |
| | | | Hoses secure and against welded lip of tubing. | | |
| | m. | Check air filter restriction indicators. Replace engine air filters and safety elements immediately, if required.**Refer to footnote 1 at end of schedules. | | | |
| | n. | Check converter coolant system pumps, connections, and hoses for leaks. | | | |
| o. | Engine exhaust wrap in good condition. | | | | |
| 20 | Fire system secure and intact? | | | | |
| 21 | Climb stairs left side of rear frame. | | | | |
| a. | Check radiator coolant level at sight glass. Check hoses for leaks. | | | | |
| b. | Check drive module coolant reservoir fluid level. Check hoses for leaks. | | | | |
| | Top of rear frame. | | | | |
| c. | Exhaust pipes and clamps in good shape and secure? | | | | |
| d. | Grating and handrails in good shape and secure? | | | | |
| e. | Check air filter restriction indicators. Replace engine air filters and safety elements immediately, if required.**Refer to footnote 2 at end of schedules. | | | | |
| 22/23 | Front and rear cab area/top of rear frame. | | | | |
| a. | Ladders, guardrails, and catwalks clean and secure? | | | | |
| b. | Lights in good condition? | | | | |

| Chart Position | Operator Daily or Pre-Shift Walk Around Item to check/inspect | | Checked | Service Required |
|----------------|--|--|---------|------------------|
| | c. | Bucket level transducer intact? | | |
| | d. | Hoist position transducer intact? | | |
| | e. | Air conditioner cover in place and secure? | | |
| | f. | Clean the windows and note any cracks. | | |
| | g. | Wiper blades in good condition? | | |
| | h. | Windshield washer reservoir level full? | | |
| | i. | Mirrors securely attached and not broken? | | |
| 23 | Lift arms (upper) - visual inspection standing in front of cab. | | | |
| | a. | Grease lines broken, twisted, or kinked? | | |
| | b. | Auto lube system functioning properly; a wet look of fresh grease at ball caps and pins? | | |
| | c. | Dump stop pads in good condition and secure? | | |
| | d. | Visual cracks in lift arms? Do NOT operate machine if cracks are present. | | |

NOTICE

Some of the remaining portions of this inspection requires the machine to be started and operated in slow speed operations. Remove frame lock from locked position and secure in unlocked position. Enable machine's starting capability. Turn KLENZ™ Enable switch to the ON position. Follow all safe operating procedures for starting the machine. Ensure all personnel are clear of the area.

| Chart Position | Item to check/inspect | | Checked | Service Required |
|----------------|-----------------------|--|---------|------------------|
| 24 | Cab interior. | | | |
| | a. | Cab door latch, hinges and weather stripping in good shape and operating properly? | | |
| | b. | Cab interior lights operating properly? | | |
| | c. | Windshield wipers operating properly? | | |
| | d. | Work lights operating properly? | | |
| | e. | Mirrors adjusted properly. | | |
| | f. | Seat and seatbelt: <ul style="list-style-type: none"> • Operating properly? • In good condition? • Seat attachment bolts tight? | | |
| | g. | Safety or instructional labels deteriorated, damaged or missing. | | |
| | h. | Radio operating properly. (optional) | | |

| Chart Position | Operator Daily or Pre-Shift Walk Around Item to check/inspect | | Checked | Service Required |
|----------------|---|---|---|------------------|
| | i. | Customer installed communication devices operating properly. | | |
| | j. | Perform any fire suppression system checks/maintenance as required by the specific system manufacturer (Refer to vendor reference material located in section 1-4 Controls and Operation). | | |
| 24 | Operational tests. | | | |
| | a. | Any unsecured items in cab that might present a safety hazard (secure all such items before starting engine)? | | |
| | b. | <p>Start engine per appropriate engine starting procedure and engine manufacturer owner's manual, if prior inspections indicate it is safe to do so. Blow horn for one to three seconds and wait at least 30 seconds before starting engine.</p> <div style="background-color: #f4a460; padding: 10px; text-align: center;">  WARNING </div> <p>Entanglement in the drive shaft or engine belts, burns if working on the engine exhaust or around hydraulic fluid or engine fluid, cuts/dismemberment if working on the radiator fan, electrical shock if working on the electrical system, skin injection from hydraulic fluid if working on high pressure side of hydraulic system, hearing loss from sonic sounds if working inside KLENZ system and other hazards exist. ALWAYS sound the horn for 2-3 seconds prior to starting the engine to alert personnel on the machine or in close proximity to it that the engine is about to start. Allow at least 30 seconds for them to clear the area before starting the engine. Check wing mirrors and all sides of machine from a seated position. If the horn is inoperable (see the following NOTICE), and if allowed by local rules and regulations, dismount the machine, and walk around it to be sure no one is on the machine or in close proximity to it before starting the engine. Always follow all local startup procedures before starting the machine. Failure to allow ample time for personnel to leave the area before starting the engine could cause entanglement, burns, cuts/dismemberment, electrical shock, hearing loss, skin injection, and other hazards resulting in serious injury or death.</p> | | |
| 24 | Operational tests (continued). | | | |
| | c. | LINCSSL [®] display monitor operating properly? | | |
| | d. | No "alarm" or "warning" messages? | | |
| | e. | Heater/air conditioner operating properly? | | |
| | f. | Move machine, for a short distance, in forward and reverse directions. Operate all controls through slow speed operation. | | |
| | | (1) Any limits out of adjustment? If problems noted, discontinue operation and correct before commencing material handling operations. | | |
| | | (2) Any binding, over travel, sluggish operation or unusual noises? If problems noted, discontinue operation and correct before commencing material handling operations. | | |
| | g. | Brakes operating properly? | <ul style="list-style-type: none"> • Dynamic Braking • Service Brake • Park Brakes | |
| | h. | Direction select switch (FNR) on left steering joystick operating properly. | | |
| | i. | Foot pedals free of obstructions and operating properly? | | |
| | j. | Backup alarm functioning properly? | | |

| Chart Position | Operator Daily or Pre-Shift Walk Around Item to check/inspect | | Checked | Service Required |
|----------------|---|---|---------|------------------|
| | k. | Steering operating properly? | | |
| | l. | Hoist and bucket joystick operating properly? | | |
| | Compressed Air system | | | |
| | a. | Repair air leaks and problems as soon as possible, as indicated by LINCS alarms and messages. | | |

NOTICE

If mechanical or safety problems are noted which might cause damage to the machine or support vehicles or personal injury, DO NOT operate the loader. Lockout the machine's starting capability, remove the key, and notify maintenance personnel of the problem(s).

Note 1: This location is based on machine model. Some models have engine air gauge restriction junction box located on top of Low Voltage Control Center (LVCC) at top of stairway.

Note 2: This location is based on machine model. Some models have engine air gauge restriction junction box located in front of the rear tire, left side.



WARNING

Crush hazards exist from unexpected equipment component movement. When inspection and service is complete, follow all lockout tag out rules, local rules, and local regulations to return the machine back to service. Failure to follow all lockout tag out rules, local rules, and local regulations for returning the machine back into operating condition could cause unexpected equipment component movement for personnel in the area, resulting in serious injury or death.

This Page Intentionally Left Blank

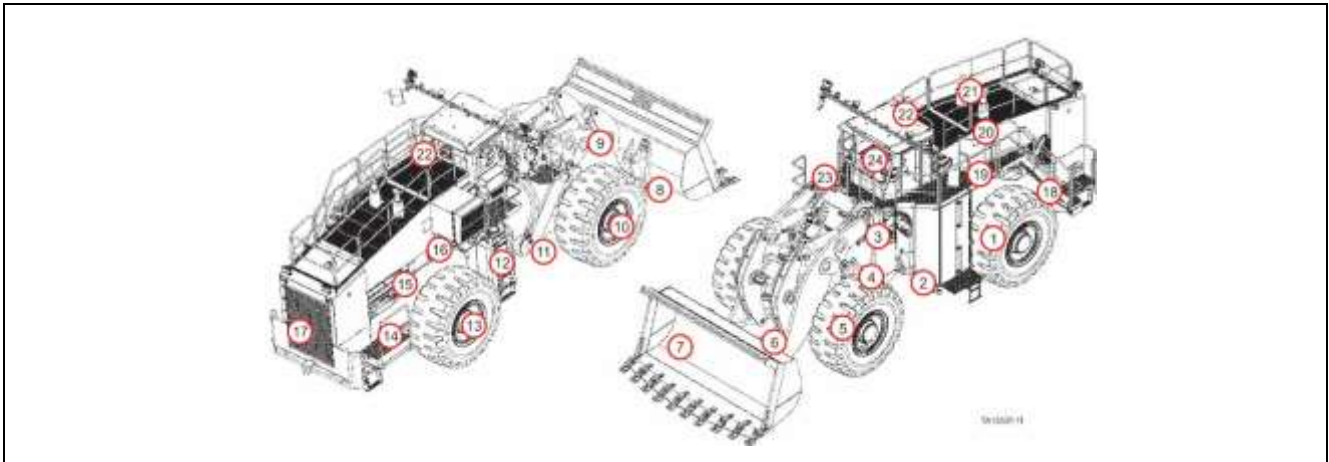

| Chart Position | Item to check/inspect | Notes |
|----------------|---|-------|
| 1 | Left rear planetary drive and wheel/tire: loose bolts cover leaks tire damage wheel damage cooling duct. | |
| 2 | Platform and high voltage cabinet: dirt debris secure high voltage cabinet coolant connections. | |
| 3 | Left pivot area: steering cylinders remote air system drain valves stop pad. | |
| | Inside rear frame: leaks gearbox oil level mounts secure loose bolts fire hazard . | |
| | Inside front frame: leaks hoses cooling ducts wiring fire hazard . | |
| | Under front frame and rear frame: leaks fire hazard | |
| 4 | Left hoist cylinder: ball caps grease lines fresh grease leaks | |
| 5 | Left front planetary drive and wheel/tire: loose bolts cover leaks tire damage wheel damage | |
| 6 | Lift arms (lower): visible cracks grease lines fresh grease | |
| | Left side, Bellcrank, area and rear of bucket: bucket pins intact stop pads Bellcrank pivot bolts grease lines fresh grease | |
| 7 | Bucket: visible cracks damage teeth lip coverage system parts. | |
| 8 | Right side, bellcrank area, and rear of bucket: bucket pins intact stop pads Bellcrank pivot bolts grease lines fresh grease. | |
| | Front Axle: access covers vents | |
| 8/9 | Lift arms (lower): grease lines fresh grease visible cracks. | |
| 10 | Right front planetary drive and wheel/tire: loose bolts cover leaks tire damage wheel damage | |
| 11 | Right hoist cylinder: ball caps grease lines fresh grease leaks steering positioned. | |
| 12 | Hydraulic reservoir: ladder fluid level relief cap valves | |
| 13 | Right rear planetary drive and wheel/tire: loose bolts cover leaks tire damage wheel damage | |
| 14 | Right rear of machine: battery box aux oil cooler | |
| 15/16 | Engine compartment (right side): coolant leaks hoses radiator drive belts leaks wiring fan grill hood grading guards engine oil level cooling air duct mufflers fire suppression system bottles nozzles hoses fire hazards engine air intake tubes hump hoses brackets air compressor air dryer. | |
| 17 | Rear of machine: radiator and hydraulic oil cooler core braking grids lights backup alarm. | |
| 18 | Left rear of machine: fuel reservoir cap central service system cover leaks of any type Rear ladder/stairway: ladder steps clean/secure | |
| 19 | Engine compartment (left side): coolant leaks hoses radiator drive belts fuel leaks engine oil leaks engine oil level wiring fan grill hood grating guards fire suppression system bottles, nozzles hoses fire hazards engine air intake tubes supports brackets hoses hump hoses air filter restriction gauges Engine exhaust wrap | |
| 20 | Fire System | |
| 21 | Top of rear frame: Exhaust pipes clamps grating handrails. radiator coolant level drive module coolant level | |
| 22/23 | Front and rear cab area/top of rear frame: ladders guardrails catwalks lights bucket position transducer hoist position transducer AC cover windows wiper blades window washer reservoir mirrors. | |
| 23 | Lift arms (upper): grease lines fresh grease stop pads visual cracks | |
| 24 | Cab interior: door latches hinges weather stripping interior lights windshield wipers exterior lighting mirrors adjusted seat belt instructional labels air leaks fire suppression system | |
| 24 | Operational tests: unsecured items engine starts LINCS display screen alarms/warnings environmental controls speed control pedal dynamic/park/service brakes over travel sluggish unusual noises direction select switch backup alarm left/right steering hoist and bucket joysticks | |

Figure 71. Operator walk around checklist (typical loader depicted)

This Page Intentionally Left Blank

Do's and Don'ts

This section contains some specific DOs and DON'Ts that apply to the operation of the loader. Compliance with the DOs and DON'Ts will be conducive to a longer operating life of the loader. Non-compliance could cause damage to the loader and also endanger the operator. These DOs and DON'Ts do not cover all possibilities but include those rules that are most frequently overlooked or violated.

Do's

- DO** - walk completely around the loader, making sure everything is clear, before starting to work.
- DO** - follow all local rules for starting the machine.
- DO** - warm up engine with Throttle Switch in the low position until the water temperature gauge indicates that the engine coolant is at least +120°F (49°C) before pushing the Throttle Switch to hi throttle. This will increase engine life (refer to engine manual).
- DO** - push the Throttle Switch to the low throttle, and let the engine run for several minutes before shutting down. This will equalize engine temperature and increase engine life (refer to engine manual).
- DO** - depress speed control pedal slowly and smoothly to increase traction and travel speed. Release speed control pedal slowly and smoothly to stop wheel spin, reduce traction, or stop the loader. Quick release will apply full dynamic braking.
- DO** - enter pile slowly with speed control pedal almost completely released. Push down on pedal a little at a time to maintain proper penetration into pile.
- DO** - use joystick controls slowly and smoothly to actuate bucket and hoist.
- DO** - release speed control pedal when digging in pile and hoist does not rise. Failure to rise indicates you have applied too much traction.
- DO** - use turn signals when appropriate.
- DO** - move steering joystick smoothly when articulating the machine (turning). Jerking the joystick causes the loader to jerk and spill its load.
- DO** - report any deficiencies or malfunctions to your foreman.
- DO** - watch out for other personnel and vehicles in the area.
- DO** - replace broken or lost bucket teeth immediately to prevent ruining the adapters.
- DO** - fill the fuel reservoir at the end of each shift. This will prevent condensation from contaminating the fuel. An adequate fuel supply will prevent possible engine damage caused by erratic engine rpm when running low on fuel.
- DO** - operate the loader from the operator's seat only.
- DO** - wear seat belt.
- DO** - avoid sudden stops with a load.
- DO** - have defects repaired immediately.
- DO** - make sure mirrors are properly adjusted and clean.

Don'ts

- DON'T** - use service brakes when changing direction or for normal stopping. All normal braking must be done by releasing the speed control pedal. The service brake may be used to hold the loader stationary, after stopping with the speed control pedal. Only in emergency should the service brakes be used to stop the loader.
- DON'T** - ram into pile. Ramming causes unnecessary shock to machine structures.
- DON'T** - use the bucket control switch from ROLLBACK to DUMP in an attempt to load the bucket. This accomplishes very little except unnecessary wear and tear.
- DON'T** - hit truck hubs with the tires or truck beds with the lift arms or bucket.
- DON'T** - store fuel in a galvanized reservoir. Fuel oil reacts with the zinc coating to form powdery flakes, which quickly clog fuel filters and strainers and damage fuel filters, strainers, fuel pumps and injectors.
- DON'T** - lift front wheels off the ground when lowering the bucket for parking. The park brakes lock the wheels.
- DON'T** - allow riders while operating the loader, unless the cab is equipped with a training seat (only a single rider allowed inside the cab with operator if so equipped).
- DON'T** - attempt to lift or transport loads in excess of rated capacity (refer to Section 01 of the Service Manual for information on capacity).
- DON'T** - walk, stand, or work under an elevated load or empty bucket.
- DON'T** - ever leave the loader cab with the engine running. Follow complete machine shutdown procedures before leaving the cab.
- DON'T** - leave the loader with the bucket elevated.
- DON'T** - transport a load with the bucket in a position that obstructs the operator's vision.
- DON'T** - operate the loader within 10 feet of live power lines.
- DON'T** - service the fuel reservoir while the engine is hot or running.
- DON'T** - smoke while servicing the fuel reservoir.
- DON'T** - remove the hydraulic reservoir cap without first bleeding the air pressure from the reservoir.
- DON'T** - remove the engine radiator cap without first bleeding the air pressure from the system.
- DON'T** - jack the machine up with the bucket and lift arms.
- DON'T** - use equipment near underground pipes, wires, or cables.
- DON'T** - lift or transport people.

Vendor Literature

VL 15B – ANSUL Checkfire 210 Detection and Actuation System
Owners Guide

VL 59A – AFEX Fire Suppression Systems

VL 97A – ANSUL Vehicle Fire Protection

This Page Intentionally Left Blank

**CHECKFIRE 210
DETECTION AND
ACTUATION SYSTEM**



OWNERS' GUIDE

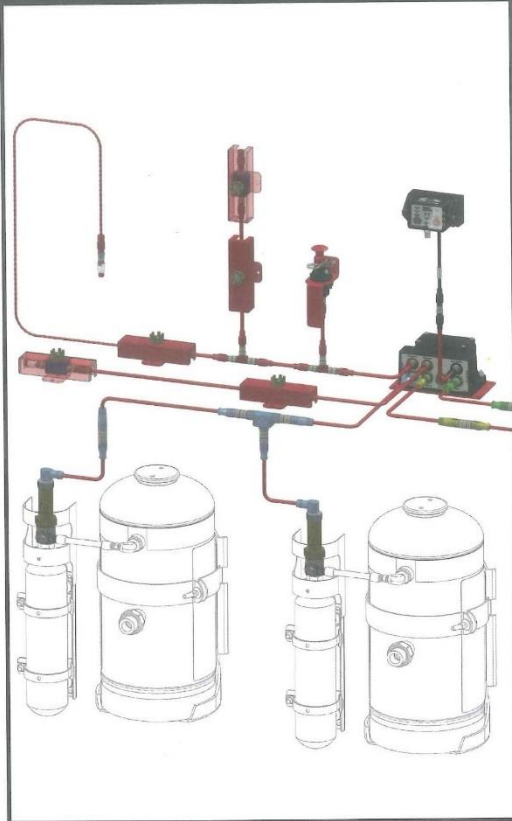

tyco
Fire Protection Products

Copyright © 2015
Tyco Fire Products LP.
All rights reserved.
Part No. 442045

CHECKFIRE 210 Detection and Actuation System Owners' Guide

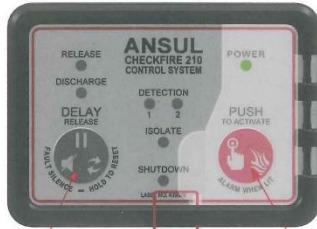

"DELAY/RESET/SILENCE" BUTTON

VISUAL SEAL

009275

"PUSH TO ACTIVATE/ALARM WHEN LIT" BUTTON AND LED

This vehicle/equipment is monitored with a CHECKFIRE 210 Detection and Actuation System which is typically connected to an ANSUL® A-101 or LVS Fire Suppression System for 24-hour fire suppression. The operator of the equipment should be provided with hands-on training by Authorized ANSUL Distributors or the end user.

This handbook is a quick-reference guide for basic operation of the CHECKFIRE 210 System. Two buttons on the display module and manual actuators provide operator control.

Fill-In System Information (as installed)

Power: Internal Only Dual (External & Internal)

External Power Supply (vehicle battery, power panel, etc.):

TD1 (Time Delay 1, seconds): 0 5 10 15

TD2 (Time Delay 2, seconds): 0 5 10 15

Time Delay Restarts: 2 Unlimited

Relay #1: Alarm Fault Not Used

Relay #2: Shutdown Alarm Not Used

Pressure Switch Auxiliary Operation: _____

IN CASE OF FIRE: Manual Actuation



PUSH RED BUTTON FOR IMMEDIATE ACTIVATION

- 1) Safely bring equipment to complete stop, set brake and shut off engine.
- 2) Break visual seal and open guard door.
- 3) Push the red "PUSH To Activate / Alarm When Lit" button.
- 4) Release circuit immediately activates the connected fire suppression system (if included, pressure switch activates auxiliary operation). **See Note below.**
- 5) Safely exit equipment and stand-by with supplemental firefighting equipment.
- 6) Optional manual actuation: Pull ring pin and strike red button on electric or pneumatic manual actuator.

Note: The red "PUSH To Activate / Alarm When Lit" LED and sounder remain steady-on for 10 sec. during initiation (release) of fire suppression system. **Post release:** Detection 1 and/or Detection 2, Shutdown, and Release LEDs and sounder continue to pulse 1 x 10 sec. If safe to re-enter equipment, push "DELAY/Reset/Silence" button to silence sounder for two hours.

Fill-In System Information (as installed)
Electric or Pneumatic Manual Actuator Location(s):

IN CASE OF FIRE: Automatic System Operation

- 1) Detector(s) registers alarm condition in hazard area and initiates the time delay notification on display module.
- 2) "PUSH To Activate / Alarm When Lit" plus Detection 1 and/or Detection 2 LEDs plus sounder:
 - a. Pulse 2 x 1 sec. until last 5 sec. of TD1; then pulse 4 x 1 sec. with Shutdown LED at start of final 5 sec. **(See DELAY/RESET/SILENCE (grey) button below for TD1 restart)**; then, only Shutdown LED is steady-on for 1 sec. indicating TD1 transferring to TD2 (restart no longer available).
 - b. Pulse 4 x 1 sec. with Shutdown LED during TD2.
 - c. Steady-on 10 sec. with Shutdown LED during initiation (release) of fire suppression system (if included, pressure switch activates auxiliary operation).
- 3) As soon as time delay begins: Safely stop equipment, set brake, shut off engine, and exit. Standby with supplemental firefighting equipment.
- 4) Post release: LEDs and sounder pulse 1 x 10 sec.

PUSH GREY
BUTTON TO
RESTART
TIME DELAY
(TD1 ONLY)



DELAY/RESET/SILENCE (Grey) Button

- 1) **Restart Time Delay:** Press and release for each restart of TD1 during alarm condition. (Limit: 2 restarts or Unlimited, see page 1.)
 - a. Must be initiated before last second of TD1. (No response after TD1 until post release.)
 - b. **Note:** Press and hold will not extend time delay period.
- 2) **Silence sounder (post discharge or fault notification) for two hours:** Press and release to silence sounder; LED fault indication will continue until fault is cleared. Any new fault or detection event will reactivate sounder.
- 3) **Reset function** is for Authorized ANSUL Distributor service technician.

FRONT PANEL INDICATORS

POWER LED:
GREEN, AMBER OR OFF

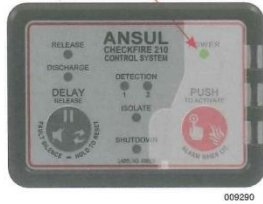

- 1) Power LED
 - a. Green steady-on indicates normal **external** power.
 - b. Green pulsing 1 x 3 sec. indicates normal **internal** power.
 - c. Amber pulsing 1 x 3 sec. indicates external power fault; system is operating on internal power. Contact Authorized ANSUL Service Technician.
 - d. Amber pulsing 1 x 10 sec. with sounder indicates internal or external power fault. Contact Authorized ANSUL Distributor for service.
 - e. Off indicates no system power. Contact Authorized ANSUL Distributor for service.
- 2) All other LEDs
 - a. LED off indicates normal status.
 - b. Amber or red pulsing with sounder: Contact Authorized ANSUL Distributor for service.

CAUTION

Any fault indication may cause the fire detection and actuation system to not function properly; immediately contact an Authorized ANSUL Distributor for service.

AFEX 2000 Series Pre-Engineered Multipurpose
Dry Chemical Fire Suppression System

AFEX W Series Pre-Engineered
Liquid Agent Fire Suppression System

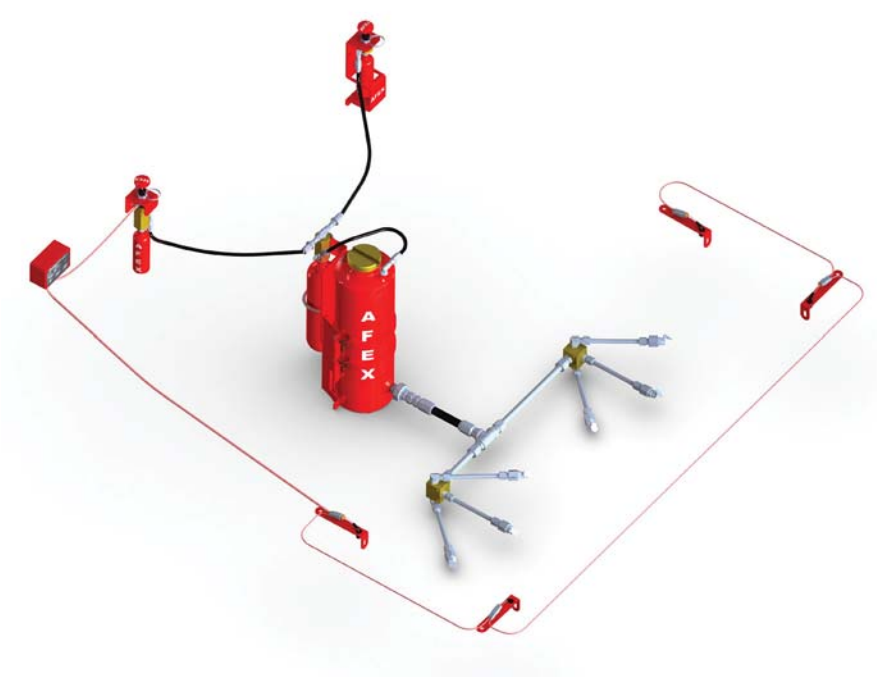

5808 LEASE LANE
RALEIGH, NC 27617
TEL (919) 781-6610 FAX (919) 787-3915
WWW.AFEXSYSTEMS.COM

Revised July 2012

This fire suppression system unit is to be installed, inspected and maintained in accordance with NFPA Standard No. 17 and the **AFEX** Installation, Operation, Maintenance, and Service Manual.

AFEX 2030 Series System

This system, when installed according to this manual, can be considered an integrated fire detection and fighting system as defined in EN 13478:2001, article 6.3.

Conforms with the EC standards:

DIN EN ISO 14982:2009

ISO 13766:2006

ISO 10605:2001

ISO 11452-2:2004

ISO 7637-2:2004

EN 894-1:1997

EN 894-2:1997

EN 1127-1:2007

EN 1127-2:2002

EN 13478:2001

EN 842:1996

ISO 7731:2003

EN 981:1996

The following Notified Body has issued a positive Statement of Opinion.

Identification of NB Statement of Opinion

Report No.: 31160512.001

Name and address of NB

TUV Rheinland of North America, Inc.

762 Park Avenue, Youngsville, NC 27596-9470

This manual should be carefully read by all individuals who have or will have responsibility for using the product.

The **AFEX** Fire Suppression System described in this document is the property of **AFEX**, Division of Bonaventure Group, Inc.

No part of the hardware or documentation may be reproduced, transmitted, transcribed, stored in a retrieval system, or translated into any language, in any form or by any means, without prior written permission of **AFEX**.

While great efforts have been made to assure the accuracy and clarity of this document, **AFEX** assumes no liability resulting from any omissions in this document, or from misuse of the information obtained herein. The information in this document has been carefully checked and is believed to be entirely reliable with all of the necessary information included. **AFEX** reserves the right to make changes to any products described herein to improve reliability, function or design. Further, **AFEX** reserves the right to revise this document and make changes from time to time in content hereof with no obligation to notify any persons of revisions or changes.

IMPORTANT:

AFEX fire suppression systems are made up of units tested within limitations contained in the *Installation, Operation, Maintenance, and Service Manual*. No modifications are to be made to the system. The system designer must be consulted whenever changes are planned for the system or area of protection. An authorized installer or system designer must be consulted after the system has discharged.

This system is limited to use on mobile equipment, when installed and maintained as described in the *Installation, Operation, Maintenance, and Service Manual*. Other uses are not permitted. **AFEX** automatic fire suppressions systems are not "intrinsically safe" and are therefore not suitable for use in potentially explosive atmospheres such as underground coal mines. The **AFEX** system has not been tested to comply with the ATEX 95 directive and is therefore not permitted for use in any underground mine that requires adherence to this directive.

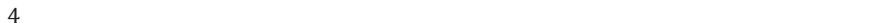

Contents

| | |
|--|-----------|
| Introduction | 6 |
| Fire Suppression System Overview | 6 |
| System Features | 7 |
| Reducing the Risk of Fire | 8 |
| What Operators Need to Know | 9 |
| What Maintenance Personnel Need to Know | 9 |
| System Operation | 10 |
| Circuit Monitor Panel Operation | 10 |
| Pre-shift System Checklist | 11 |
| In the Event of a Fire | 12 |
| After the Fire is Out | 13 |
| Routine Fire Suppression System Maintenance | 14 |
| Maintenance Interval Considerations | 15 |
| Choosing a Service Provider | 16 |
| Warranty | 18 |
| Disclaimer of All Other Warranties | 18 |
| Limitation of Liability | 18 |

Introduction

Heavy duty mobile equipment is larger and more expensive than ever before. Production losses from downtime coupled with high repair and replacement costs increase the importance of adequate fire protection.

Because of the location of the operator on modern equipment, together with noise suppression and personnel guarding, a fire on board can become severe before it is even noticed. The size of the machines makes operator egress difficult and protective guarding hampers the use of hand portable fire extinguishers.

As a permanent part of the vehicle, the **AFEX** system allows effective fire suppression in normally inaccessible areas. Operator safety is also greatly enhanced. Detection and automatic actuation allow for early system activation, alerting the operator and protecting the capital investment.

This manual is intended to acquaint you with the **AFEX** Fire Suppression System. This manual is not to be considered a detailed installation guide and this manual provides no instructions for the installation, recharging, or regular inspection and maintenance of an **AFEX** system. A detailed *Installation, Operation, Maintenance, and Service Manual* is available upon request from **AFEX**. Should you have any questions, please direct them to **AFEX** or an authorized **AFEX** distributor.

Fire Suppression System Overview

A fire suppression system is a heavy equipment accessory that is designed to help reduce damage and losses related to fire. Its purpose is to suppress a fire long enough to allow access to, or the arrival of fire fighting equipment. Fire suppression systems are not designed or intended to extinguish all fires, particularly when unusual amounts of combustible materials and an ample oxygen supply are present.

Fire conditions could occur which exceed the extinguishing capacity of the fire suppression system, possibly resulting in temporary suppression but not total extinguishment. Therefore, it is extremely important that alternative fire fighting equipment be available in case the system does not totally extinguish a fire.

The **AFEX** vehicle fire suppression system discharges A:B:C dry chemical powder and/or **AFEX** liquid agent into the protected areas of the machine, typically the engine and transmission compartments. The system is installed as part of the vehicle and consists of detection, actuation, and distribution components.

AFEX offers two types of system actuation: automatic & manual only. Automatic systems may also be manually actuated.

(continued on next page)

The system is installed as part of the vehicle and consists of detection (automatic systems only), actuation, and distribution components.

Detection components include sensors and/or linear detection wire, the circuit monitor panel, and wire.

Actuation components include the firing mechanism or manual actuators, electric actuator, nitrogen cartridges, slave actuators, and hose.

Distribution components include the agent tank, hose, stainless steel tubing, and nozzles.

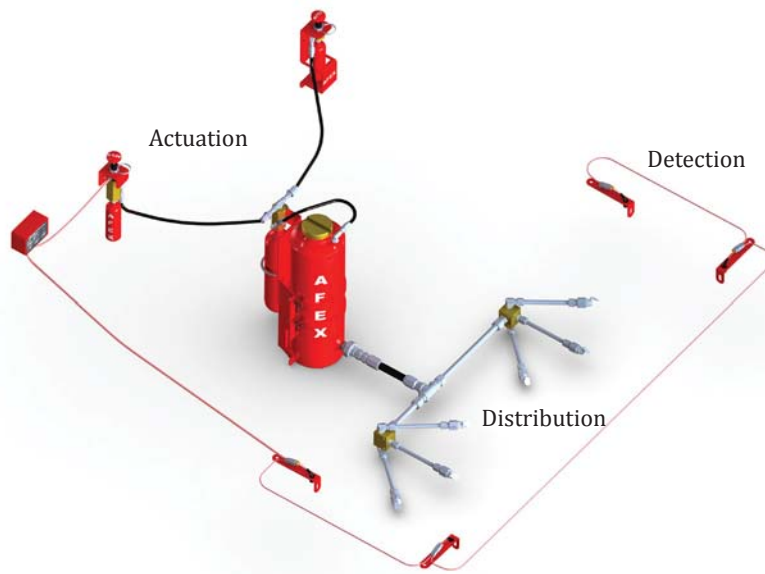

System Features

Familiarize yourself with the features of the **AFEX** system. If you need help identifying these features, contact your local distributor.

Your system may include some or all of the following:

- Automatic Detection
- Circuit Monitor Panel
- Automatic Actuator with Manual Override
- Exterior Remote Actuator
- A:B:C Dry Chemical Powder
- **AFEX** Liquid Agent
- Stainless Steel Distribution
- Automatic Engine Shutdown
- External Horn and/or External Lights

Reducing the Risk of Fire

Your risk of equipment fires, and the damage resulting from a fire, can be reduced by following the tips below:

- Maintain vehicles properly and regularly.
 - Frequently clean combustible debris and fuels from belly pans and engine and transmission compartments.
 - Check all oil, hydraulic fluid and gas lines for cuts, abrasions, or wear. Replace as needed.
 - Inspect all oil, hydraulic, and gas line fittings for tightness. Clean off all residue and tighten.
 - Check braking system for proper adjustment especially if brakes overheat when not engaged.
 - Check all possible ignition points (engine block, exhaust manifolds, turbochargers, etc.). Make sure oil, hydraulic fluid, and gas lines are not in contact with these ignition points.
 - Clean vehicle of all combustible debris, dry vegetation, grain particles, coal dust, etc. Remove any oil and fuel drippings.
 - Check all electrical lines and connections for tight fit, wear or abrasion. Replace any defective electrical equipment or wiring.
- Have fire response plan in place.
 - Train personnel on the use of fire suppression systems and portable fire extinguishers.
 - Follow proper fire suppression system maintenance intervals.
 - Have additional fire fighting equipment available on-site.
 - Avoid parking equipment side by side at night.

What Operators Need to Know

- The Circuit Monitor Panel & firing mechanism (or manual actuator) are located in the cab, typically within your view and arm's reach.
- The agent dispersion nozzles are typically located in the engine and transmission and other hazard areas.
 - The operator's cab is not protected.
 - The system will not suppress fires outside the machine.
- Bring the vehicle to a stop and shut down the machine immediately when a fire condition is observed.
- Manually actuate the system immediately when a fire condition is observed, even if it is an automatic system, if it has not already actuated automatically.
- Hand portable fire extinguishers are recommended and are useful if re-ignition occurs or if fires originate outside of the protected area.
- In the event of a fire, the immediately inform the appropriate on-site personnel in order to maximize fire fighting efforts.

What Maintenance Personnel Need to Know

- Fire suppression system components are installed on the machine to protect the engine and transmission compartments against fire.
 - Tampering with, repositioning, removing or damaging components can adversely affect the fire suppression system's performance or even prevent the system from functioning properly.
 - Should you have concerns regarding the fire suppression system installation, certification or repair, contact the local **AFEX** distributor or service agent immediately.
- To avoid damage to the Circuit Monitor Panel (if equipped), disconnect power to the panel prior to welding on or jump starting the machine.
- After performing major maintenance procedures or repairs to the equipment, the engine, or transmission, contact the local distributor to inspect and restore the fire system to proper operating condition.

IMPORTANT:

This system is made of units tested within limitations contained in the detailed installation manual. The system designer must be consulted whenever changes are planned for the system or area of protection. An authorized installer or system designer must be consulted after the system has discharged.

System Operation

1. A fire starts in the protected area of the machine.
2. The system is automatically or manually actuated.
IMPORTANT: If you see signs of a fire before the system automatically actuates, manually actuate the system. Rapid response is critical in successfully suppressing the fire.
 - a. (Automatic Actuation) The heat from the fire activates the sensors or linear detection wire, which sends a signal to the Circuit Monitor Panel to fire the electric actuator.
NOTE: **AFEX** sensors activate at 300°F (148.89°C) and reset at 275°F (135°C). **AFEX** linear detection wire is rated at 356°F (180°C).
 - b. (Manual Actuation) The operator manually actuates the system by pulling the safety pin and striking the push knob on the cab or exterior actuator.
3. The seal on the actuation cartridges is punctured, releasing the nitrogen gas which flows through the actuation lines.
4. The nitrogen gas activates the slave actuator, puncturing the seal on the pressurizing cartridge(s), pressurizing the agent tank.
5. The agent flows through the distribution network and sprays out of the nozzles into the protected area of the machine.

Circuit Monitor Panel Operation

1. A sensor (or the linear detection wire) is activated.
2. The ALARM light illuminates and audible alarm sounds. The discharge delay cycle begins.
 - a. The discharge delay cycle may be set from 0 to 30 seconds. Pushing the SYSTEM RESET button will reset the discharge delay cycle.
NOTE: The audible alarm remains on, even after the system discharges, unless the sensor resets or the ALARM SILENCE button is pressed.
The ELECTRIC ACTUATOR light illuminates.
3. At 65% of the discharge delay cycle, the DISCHARGE WARNING light illuminates.
4. At the end of the discharge delay cycle, the electric actuator fires.

Pre-shift System Checklist

If any of the following are found in a condition that is not as indicated, immediately notify the proper safety and/or maintenance personnel, as the system may not be operational:

- There are no signs of a fire having occurred on the machine.
- There is no sign of the A:B:C dry chemical or **AFEX** liquid agent on the machine or the ground, indicating a possible system discharge.
- The safety seal and safety pin are in place in all system actuators.
- The green POWER light on the Circuit Monitor Panel is illuminated.
- None of the TROUBLE lights on the Circuit Monitor Panel are illuminated.



- The Circuit Monitor Panel's audible alarm is silent.
- There is no visible damage to any of the following components:
 - The agent tanks and mounting brackets
 - Hose and hose fittings
 - Detection components
 - Actuators and mounting brackets
 - Nozzles
- The fire suppression system components are not in contact with other parts of the machine.
- The portable fire extinguisher is charged and in its proper place.
- Any required repairs to the machine have been made.

In the Event of a Fire

In the event of a fire, **remain calm**, and **do not panic**. The actions taken by the operator can directly affect the effectiveness of the fire suppression system as well as the overall outcome of the fire.

1. Safely bring the vehicle to a complete stop in a safe location.
2. Turn off the machine's motor and set the brake.
IMPORTANT: Failure to turn off the vehicle may:
 - Allow the pumps to feed fuel or hydraulic oil onto the fire.
 - Allow energized electrical circuits to re-ignite the fire.
 - Allow the cooling system fan to exhaust some of the A:B:C dry chemical powder, thereby reducing effectiveness.
3. Manually actuate the fire suppression system.
 - a. Remove safety pin from the actuator.

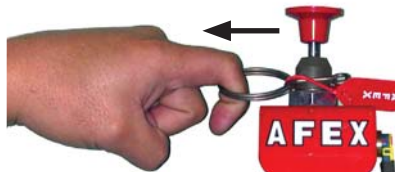

- b. Strike push knob with force. Use a closed fist or the base of your palm to generate the most force.
NOTE: The firing mechanism and/or remote actuator may not always be mounted in a vertical orientation.



IMPORTANT: Even if your system is equipped with an automatic actuation package, DO NOT wait for the system to automatically actuate! Actuate the system manually as soon as you are safely parked with the engine off.

(continued on next page)

4. There will be a noise from the release of the nitrogen gas.
5. The agent(s) will be discharged into the protected area of the machine. An A:B:C dry chemical powder discharge will be visible as a large yellow cloud, a liquid agent discharge will not be visible from outside the protected area.



NOTE: Breathing the A:B:C dry chemical is not toxic, however it may cause temporary irritation to the eyes, skin, or respiratory system.

6. Exit the machine and move to a safe distance away from the machine.
7. Standby with a portable fire extinguisher to make sure that any smoldering debris has been extinguished and there is no fire re-ignition.
8. Call your local fire department, and site supervisor and/or maintenance department to alert them to the situation and follow any applicable fire response procedures.
9. In the event of fire re-ignition or suppression only, additional fire fighting equipment will be necessary to ensure fire extinguishment.

After the Fire is Out

1. Use water or compressed air to clean the equipment.
2. Determine the cause of the fire and make the required repairs.
3. Contact your local **AFEX** distributor to schedule a service and recharge of your fire suppression system.

IMPORTANT:

DO NOT place the vehicle back in service until it has been repaired and the cause of the fire has been determined and rectified.

DO NOT place the vehicle back in service until the fire suppression system has been serviced and recharged.

Routine Fire Suppression System Maintenance

AFEX fire suppression systems are designed and built to withstand adverse environmental and operating conditions; however, periodic inspection and maintenance is necessary to insure that the system is fully operational when required.

AFEX fire suppression systems are to be installed, inspected, maintained, and tested in accordance with NFPA 17, the National Fire Protection Association's Standard for Dry Chemical Fire Extinguishing Systems. It is the responsibility of the owner to make sure the required daily, monthly and semiannual inspection and maintenance procedures are performed.

This standard requires the following:

1. DAILY INSPECTIONS

- Check the tubing, nozzles, nitrogen cartridges, and other system components for loose mountings or obstructions. Tighten as required.
- Check the sensors and wiring for damage, broken wires or broken connections. Repair as required.
- Ensure that all manual actuation rods are secured with a safety pin and seal.
- Ensure that portable fire extinguishers are available and fully charged.
- Check that any oil leaks or electrical problems on the vehicle are corrected.
- Remove all debris accumulation from the vehicle's protected areas.

2. THIRTY (30) TO NINETY (90) DAYS INSPECTION

On a monthly basis, this inspection shall include verification of the following:

- That the extinguishing system is in its proper place.
- The manual actuators are unobstructed.
- The tamper indicators and seals are intact.
- The maintenance tag or certificate is in place.
- No obvious physical damage or condition exists that might prevent operation.
- Nozzle covers are intact and undamaged.

3. SEMIANNUALLY

(To be performed by a trained service technician)

- Examine the dry chemical agent.
- Examine all detectors, nitrogen cartridges, agent tanks, actuators, hose assemblies, tubing, nozzles, alarms, and all auxiliary equipment.
- Verify that the agent distribution network is not obstructed.
- Ensure the fire hazard has not changed.

4. INTERVALS NOT TO EXCEED TWELVE (12) YEARS

- All hose assemblies shall be hydrotested to the following pressures:

Actuation hose 1250 psi

Distribution hose 565 psi

(continued on next page)

- The agent tank(s) shall be hydrotested to the following pressures:

| | | |
|------------|---------------------------------|---------|
| PN A200720 | 20 Lb. Dry Chemical Agent Tank | 585 psi |
| PN A200505 | 30 Lb. Dry Chemical Agent Tank | 585 psi |
| PN A202000 | 60 Lb. Dry Chemical Agent Tank | 585 psi |
| PN A200507 | 125 Lb. Dry Chemical Agent Tank | 520 psi |
| PN A200511 | 15 Gallon Liquid Agent Tank | 520 psi |
| PN A201000 | 5 Gallon Liquid Agent Tank | 585 psi |

In addition to NFPA requirements, the DOT requires:

INTERVALS NOT TO EXCEED TEN (10) YEARS

- All nitrogen cartridges larger than 2 oz. shall be hydrotested.

In addition to the previously mentioned inspections, **AFEX** requires the following supplemental maintenance:

1. INTERVALS NOT TO EXCEED FIVE (5) YEARS

- Replace the electric actuator, PN A709500. (automatic systems only)
- Replace the liquid agent, PN A200515. (liquid agent systems only)
- Hydrotest or replace hoses.

2. INTERVALS NOT TO EXCEED TEN (10) YEARS

- Replace all 1 oz. (PN A320000) and 2 oz. (PN A360000) nitrogen cartridges.

IMPORTANT: Make sure the machine is off before inspecting or servicing the fire suppression system. Always wear the proper safety equipment.

Maintenance Interval Considerations

Based on your local environmental and/or operating conditions, system inspection and maintenance services may be required in shorter intervals than those previously described. In our experience, a complete inspection every 3-4 months or 1,000-1,200 operating hours (whichever comes first) is optimal for ensuring the system is fully operational. Please consult with your local service provider and local authority having jurisdiction to determine an appropriate inspection and maintenance interval for your systems

Per NFPA 17, system inspections and recharges should be performed by a factory trained **AFEX** system technician. Procedures for inspection, maintenance and recharge can be found in the *System Inspection and Recharge Instructions*, available from **AFEX**.

Choosing a Service Provider

We recommend that you work with your local **AFEX** distributor or service agent. If you don't know who your local **AFEX** distributor is, please contact our office to find out.

Regardless of who you choose to perform your service, they should:

- Be experienced and comfortable working on fire suppression systems for heavy equipment in heavy duty environments – not a general fire protection service provider for buildings, restaurants or simply, portable extinguishers.
- Have factory training for installation and maintenance on the products they carry.
- Maintain an inventory of recharge and repair parts for prompt installation and service.
- Respond promptly with on-site service.
- Provide training and help develop a fire response plan.

Your local **AFEX** representative is:



Warranty

AFEX warrants its Fire Suppression System against manufacturing defects for six (6) months from the date of purchase (hereinafter “the warranty period”) by the user **PROVIDED THAT** the user gives written notice to **AFEX** within thirty (30) days of discovery of such defect and within the warranty period and **FURTHER PROVIDED THAT** if **AFEX** so instructs, such part is promptly returned, freight prepaid, to **AFEX**. In the event proper notice of defect occurs within the warranty period, **AFEX** will repair and/or replace any part which, in its opinion, contains a manufacturing defect and has not been tampered with or misused or exposed to corrosive conditions. **IN NO CASE SHALL AFEX BE LIABLE FOR INCIDENTAL OR CONSEQUENTIAL DAMAGES OR FOR LOSS OF PROFITS.**

Disclaimer of All Other Warranties

THE EXPRESSED WARRANTY ABOVE IS THE EXCLUSIVE REMEDY AND IS IN LIEU OF ALL OTHER WARRANTIES WHETHER EXPRESS OR IMPLIED. AFEX SPECIFICALLY EXCLUDES ANY WARRANTIES OF MERCHANTABILITY AND ANY WARRANTIES OF FITNESS FOR A PARTICULAR PURPOSE. AFEX does not assume, or authorize any person to assume for it, any other liability in connection with the sale of its products.

Limitation of Liability

Notwithstanding the Warranty and Disclaimer of All Other Warranties, **AFEX** limits any liability it may have to the purchase price of the fire suppression system.



AFEX
FIRE SUPPRESSION SYSTEMS

5808 LEASE LANE
RALEIGH, NC 27617
TEL (919) 781-6610 FAX (919) 787-3915
WWW.AFEXSYSTEMS.COM

SM-4-OOM-B

Vehicle Fire Protection

An Owner's Manual for ANSUL
Fire Suppression/Detection Systems

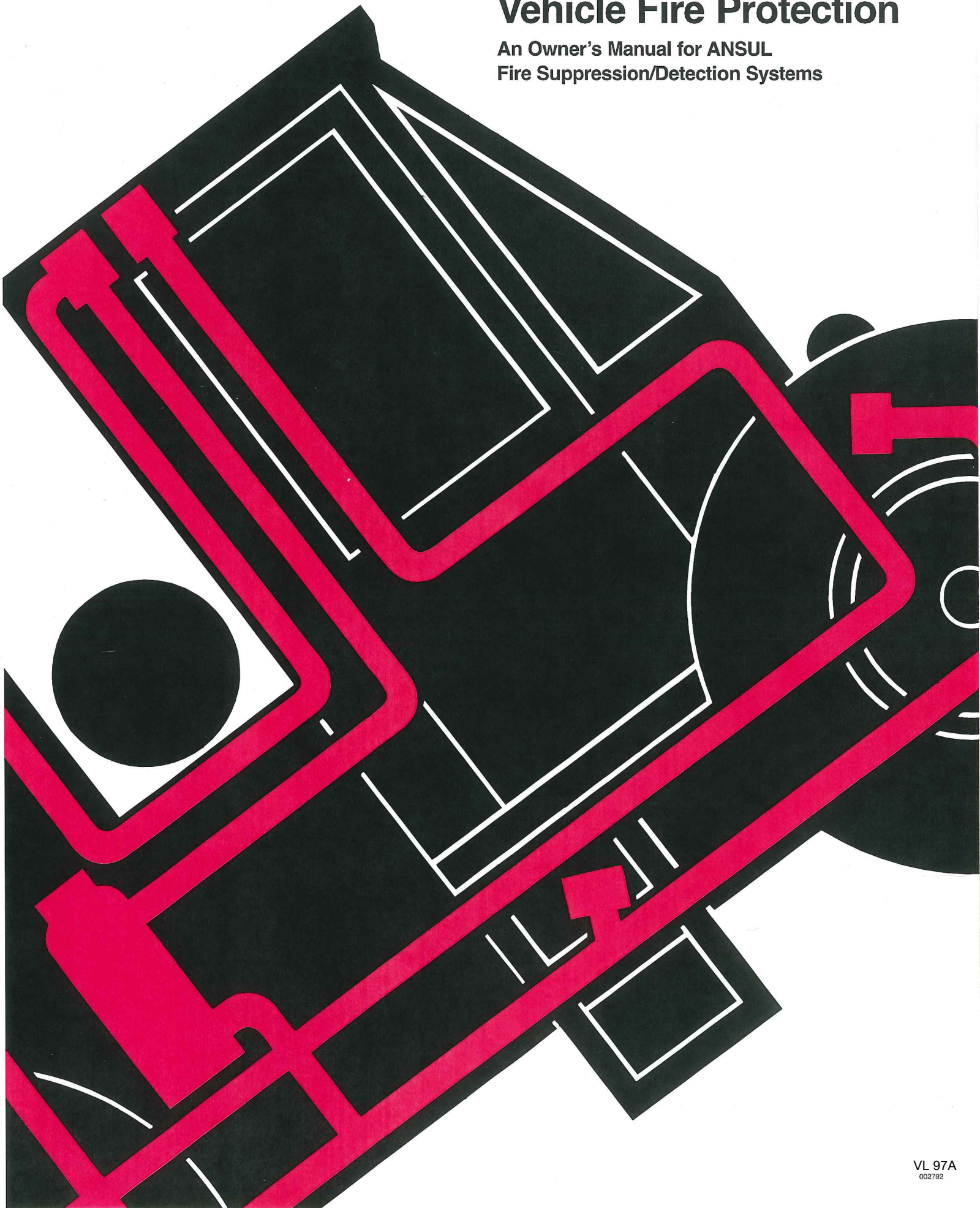

Off-road vehicles do have fires

Statistics show that off-road vehicles burn...with alarming frequency. These vehicles are susceptible to fire for several reasons. They often operate steady for several hours at a time (sometimes around the clock). They use flammable liquids – lubricating oil, gasoline, diesel oil, greases and hydraulic fluids – in their normal operation. They also generate heat – from engine blocks, manifolds, turbochargers and brake systems – which can ignite these flammable liquids and debris.

Since the passage of the federal and state clean air acts, many vehicles, including most busses operated by mass transit authorities and state agencies, have been converting to cleaner burning fuels such as LPG, LNG, and CNG instead of gasoline or diesel fuel. Use of these fuels is an essential component of improving our environment, but their use raises the possibility of dangerous gas leaks.

When fire breaks out, it can result in expensive repair or replacement of valuable equipment, costly downtime or loss of business continuity. Worse yet, it can mean serious personal injury to vehicle operators or passengers.

Insurance companies are well aware of these facts. That's why insurance rates are skyrocketing.

As the owner of a vehicle equipped with an ANSUL Fire Detection/Suppression System, you've taken an important step in facing the fire problem. You are dramatically reducing your potential fire loss and helping to ensure personnel safety.

This owner's guide has been provided to help you understand how your ANSUL Fire Detection/Suppression System works, your responsibilities for fire prevention and maintenance, and what to do in case of fire. In no way is this guide intended to provide detailed installation instructions. Should you have any questions or require assistance, contact your nearest authorized ANSUL products distributor or ANSUL Technical Services.

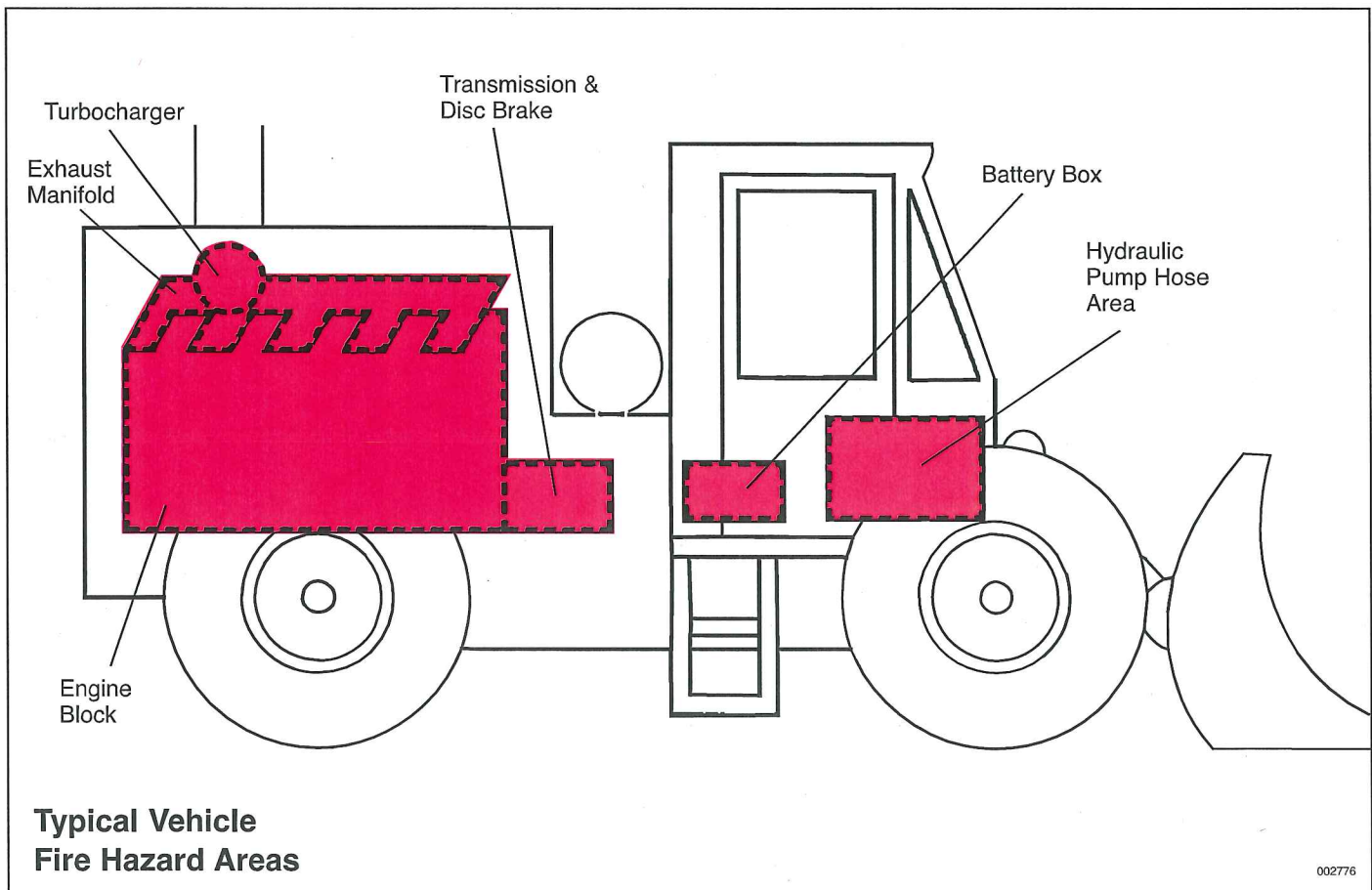

SAFETY PRECAUTIONS

The fire system described in these materials is a suppression system only and is not designed or intended to extinguish all fires, particularly when unusual amounts of combustible materials and an ample oxygen supply are present. It is extremely important that alternative firefighting equipment be available in case the system does not totally extinguish a fire.

Use extreme care to prevent the accumulation of debris, combustible materials and fluids which could intensify the fire or cause it to spread to areas where there was no previous potential for fire.

If modifications are made to the equipment being protected or if the fire detection and/or suppression system is disconnected for any reason, make certain the fire equipment is immediately inspected and tested by an authorized ANSUL vehicle systems distributor.

If an automatic fire detection and actuation system has not been supplied or has been disconnected, system actuation and discharge will not occur unless the fire suppression system is manually actuated. Reliance on a manual release system usually results in a slower reaction to fire.

Your role in protecting your vehicle from fire

Your ANSUL Fire Suppression System is custom-designed to protect specific hazard areas on your vehicle. It's been carefully engineered for reliability and built to the highest quality standards. Every component has been tested to ensure long life and dependable performance.

With proper maintenance, your ANSUL Fire Suppression System should give you years of fire protection.

The main purpose of the manual, however, is to explain the most basic form of fire protection – fire prevention. It outlines steps you can take to prevent a disastrous fire. Precautions which can greatly reduce the risk of serious fire damage.

Fire prevention on vehicles relies upon two basic factors:

1. Inspection and preventative maintenance at points where fires are most likely to start – engine blocks, electrical systems, turbochargers, exhaust manifolds and brake systems.
2. Regular cleaning of all areas where flammable materials such as fuel, oil, grease, hydraulic fluid and combustible debris may collect.

Vehicle Fire Prevention Maintenance

The following is a suggested daily maintenance outline which can help reduce the risk of fire on your vehicle.

CAUTION: Take care during vehicle maintenance, cleaning, or welding. To avoid unintentionally setting off the system and the discharge of agent, do not cut, pinch, or apply heat exceeding 200 °F (93 °C) to the detection lines of the system.

1. Check all oil, hydraulic fluid and gas lines for cuts, abrasions or undue wear. Replace as needed.

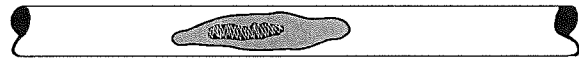

000620

2. Inspect all oil, hydraulic and gas line fittings for tightness. Clean off all residue and tighten.

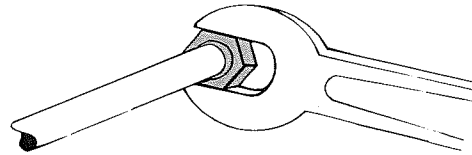

000621

3. Inspect and clean engine area. Depending upon the operation of the vehicle, use water or steam to clean it. Schedule cleaning for the end of the work shift when heat buildup may occur after the engine is shut down.

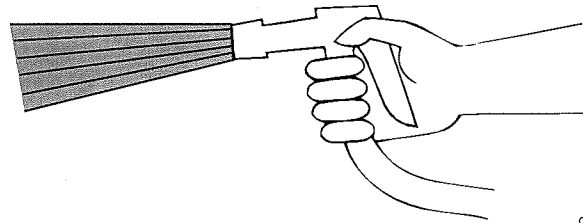

000622

4. Check braking system for proper adjustment – especially if brakes overheat when not engaged.

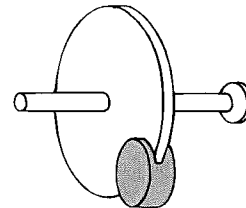

000623

5. Check all possible ignition points (engine block, exhaust manifolds, turbochargers, etc.). Make sure oil, hydraulic fluid and gas lines are not in contact with these ignition points.

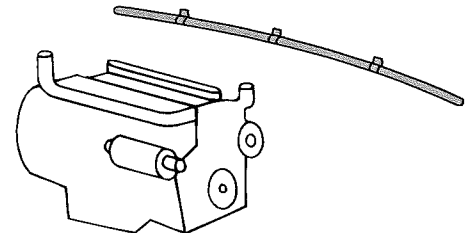

000624

6. Clean vehicle of all combustible debris – dry vegetation, grain particles, coal dust, etc. Also, remove any oil and fuel drippings.

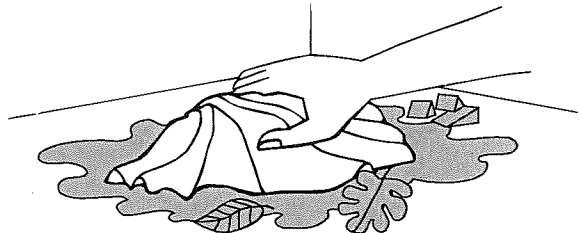

000625

7. Check all electrical lines and connections for tight fit, wear or abrasion. Replace any defective electrical equipment or wiring.

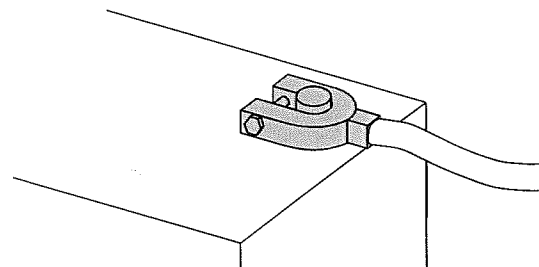

000626

How your ANSUL Fire Suppression System works . . . manually

1. A fire starts in the protected area. Equipment operator should bring equipment to a complete stop, set the brake, and turn off the engine.

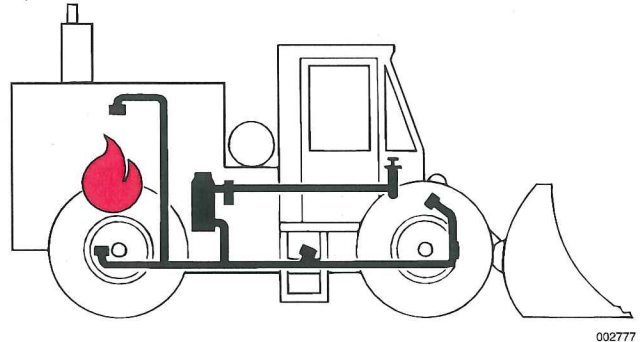

2. Equipment operator pulls the ring pin and strikes the plunger on the manual actuators. Pressure from the actuator causes the ANSUL Fire Suppression System to actuate.

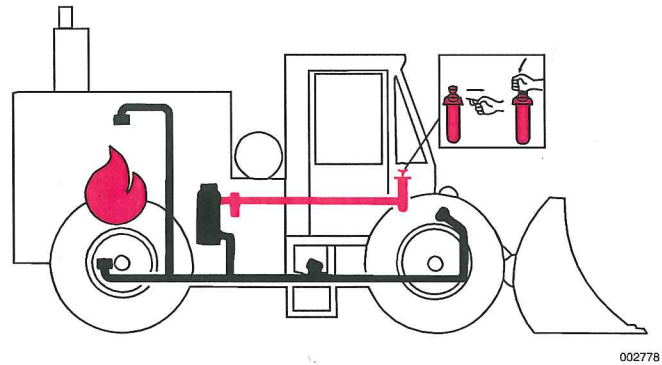

3. Expellant gas pressure "fluidizes" the dry chemical extinguishing agent and propels it through distribution hose.

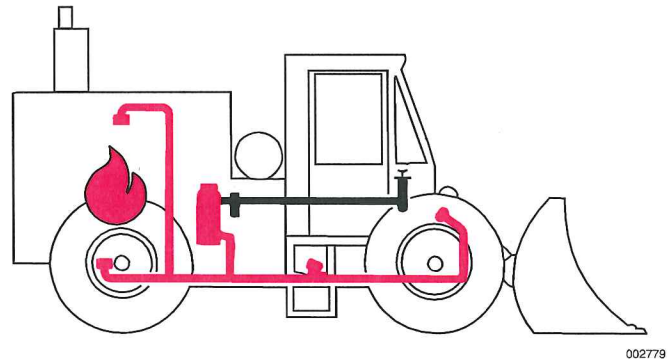

4. Dry chemical extinguishing agent is discharged through fixed nozzles into protected areas, suppressing the fire.

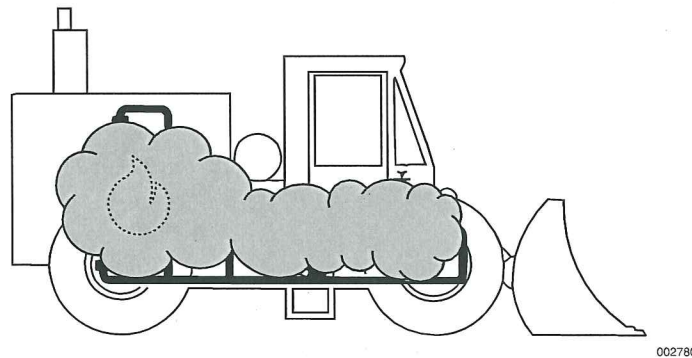

And you can have automatic 24 hour protection with ANSUL CHECKFIRE Detection and Actuation Systems . . .

How the system works with optional CHECKFIRE Electric Detection and Actuation

1. A fire starts in the protected area.

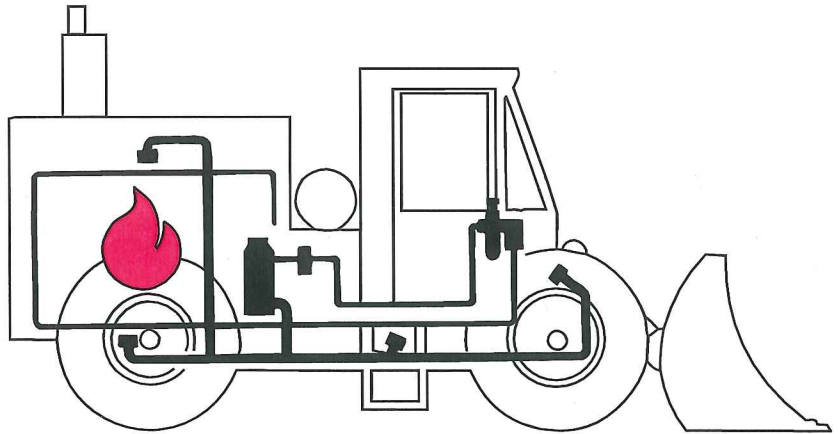

002781

2. Linear, spot detectors, or Triple IR flame detectors signal the system control module indicating that a fire has started in the protected area.

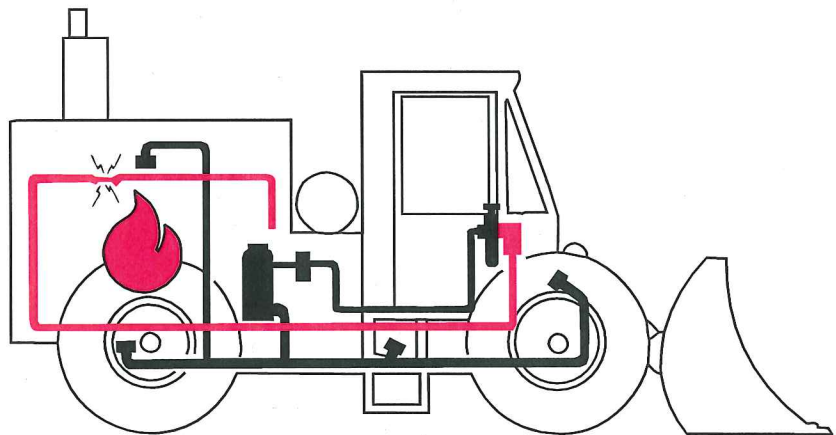

002782

3. The Control Module actuates the fire suppression system. The module will also provide time delay, shut down functions and activation of auxiliary vehicle components in accordance with your installation.

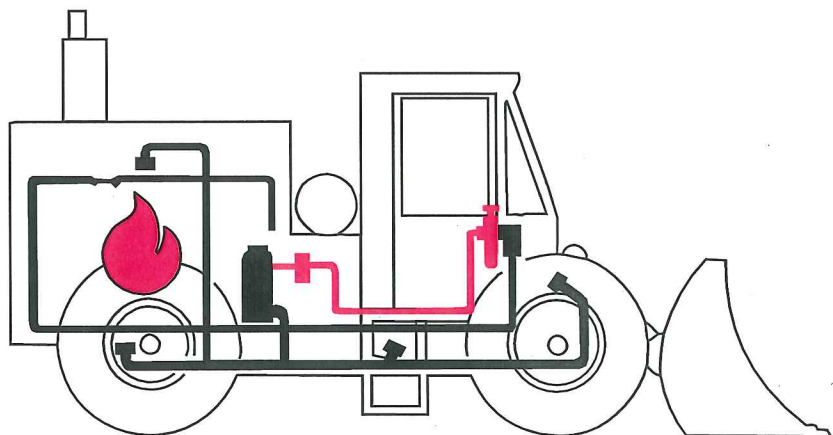

002783

-
4. Expellant gas pressure “fluidizes” the dry chemical extinguishing agent and propels it through the distribution hose.

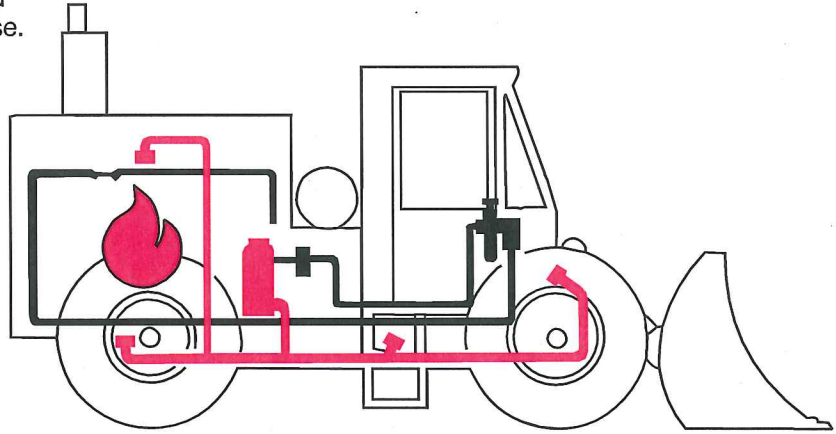

002784

-
5. Dry chemical extinguishing agent is discharged through fixed nozzles into protected areas, to suppress the fire.

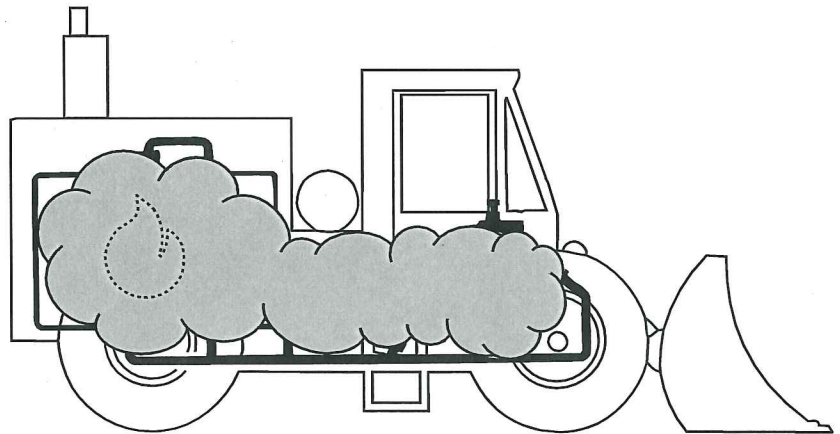

002785

Optional LVS (Twin Agent) Fire Suppression System

Along with dry chemical fire suppression system protection, some vehicles, because of their size, require an additional type of system. This type of system is called a twin agent system. An ANSUL LVS, Liquid Agent System, is designed to discharge wet chemical into the protected hazard areas simultaneously with the dry chemical discharge. The addition of the wet chemical produces a cooling effect onto the flammable fuel and the surrounding surface areas. The wet chemical can flow into hard to reach areas where fuels may have flowed into.

Make sure your ANSUL Fire Suppression System is

The ANSUL Fire Suppression System is your second line of fire defense in case your fire prevention efforts are not enough. However, in order to perform properly, your ANSUL System requires periodic inspection and maintenance.

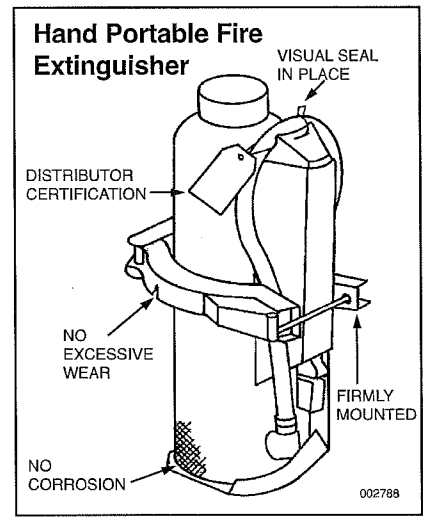
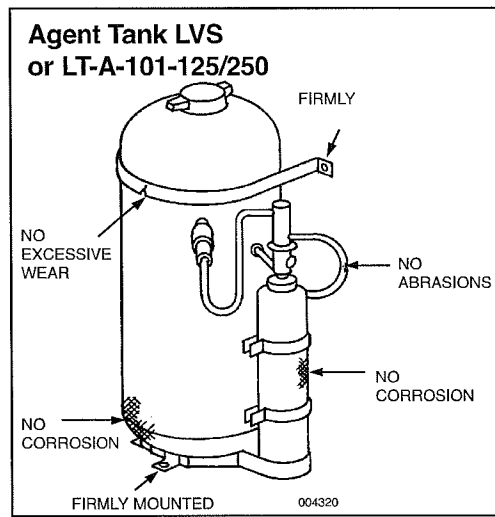
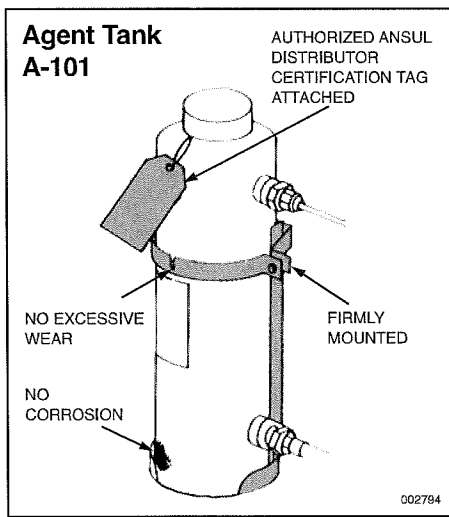
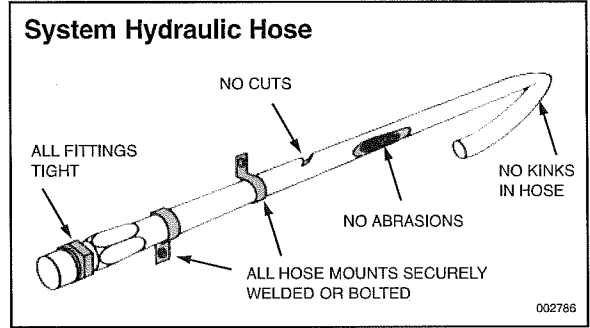
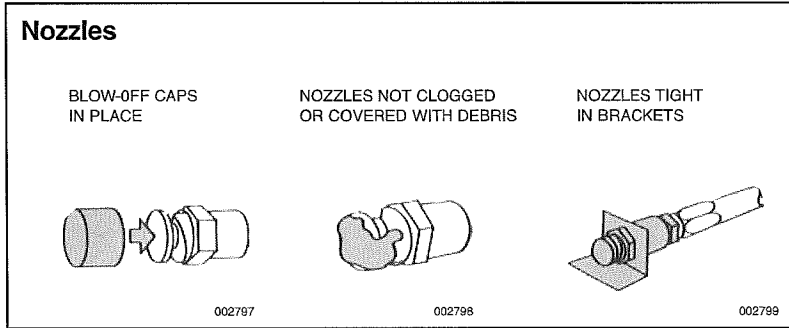

kept in good working order.

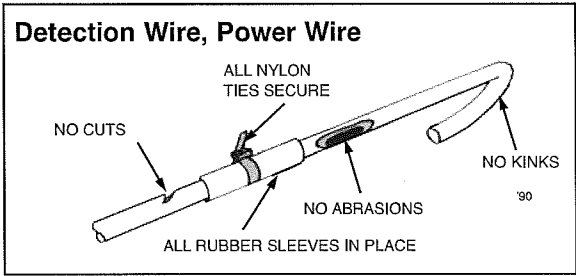
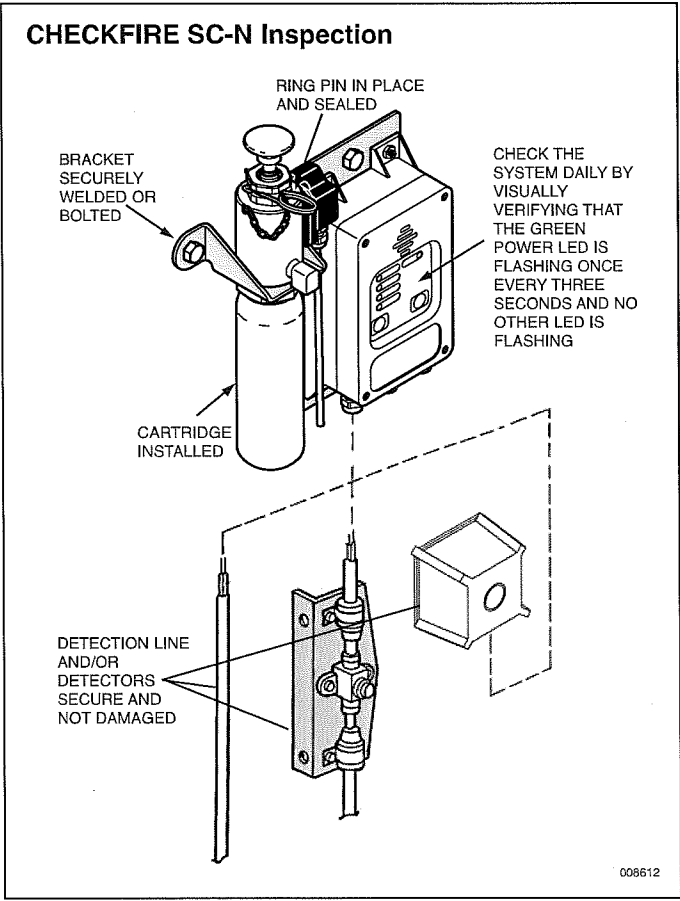
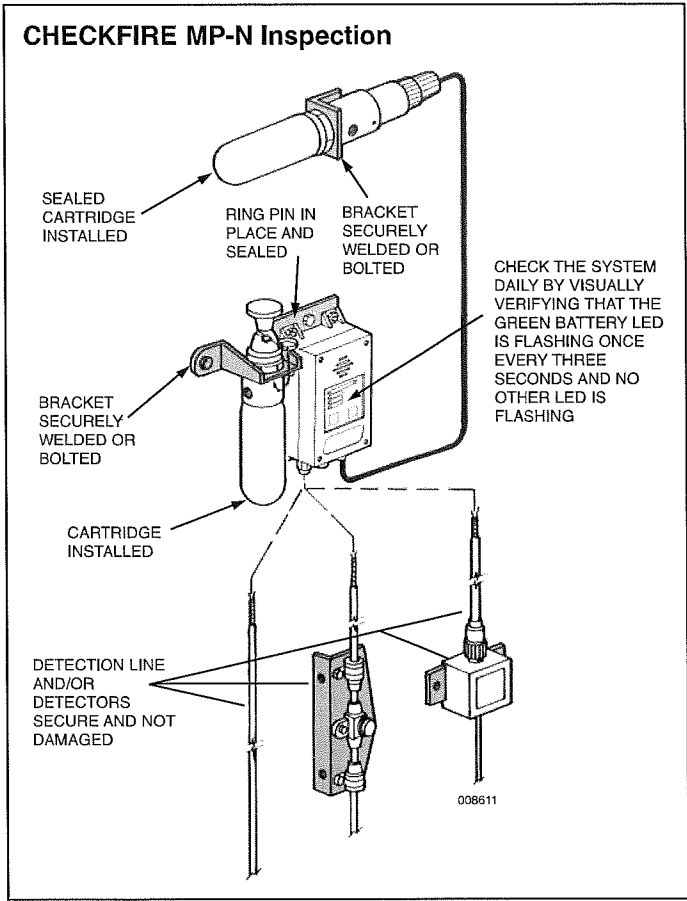

Provide for vehicle modification

Your ANSUL Fire Suppression System was custom designed and installed on your vehicle to protect specific hazard areas from fire. Should you add accessory equipment to your vehicle at a later date, or make major mechanical modifications, you may be reducing the capabilities of the ANSUL Fire

Suppression System. When such modifications are made, contact your ANSUL distributor. He can reevaluate your ANSUL System to ensure it protects all hazard areas from fire.

Provide for periodic maintenance

Periodic maintenance is essential to ensure that your ANSUL Fire Suppression System is operational. Contact your ANSUL distributor for periodic follow-up, in-depth inspection and maintenance.

Protect against fires outside of the hazard area

Hand portable fire extinguishers are an effective way to suppress fires which may occur away from the vehicle, or in areas not protected by the ANSUL Fire Suppression System. Your ANSUL distributor can recommend the proper size, type and placement of hand portable extinguishers and train your personnel in their operation, inspection and maintenance.

Should fire occur in an area not protected by the ANSUL Fire Suppression System, a hand portable fire extinguisher should be employed as follows:

- 1.** Shut off the vehicle's engine and set brakes.
- 2.** Evacuate the vehicle and secure a hand portable fire extinguisher.
- 3.** Approach the fire from the upwind side.
- 4.** Actuate the hand portable fire extinguisher per instructions printed on the extinguisher's nameplate.
- 5.** Once the fire is extinguished, stand by in case the fire reflash.

In the event of a fire on your vehicle

To manually operate system:

1. Shut off the vehicle

2. Set the brakes

3. Pull the ring pin on manual actuator and strike the red button

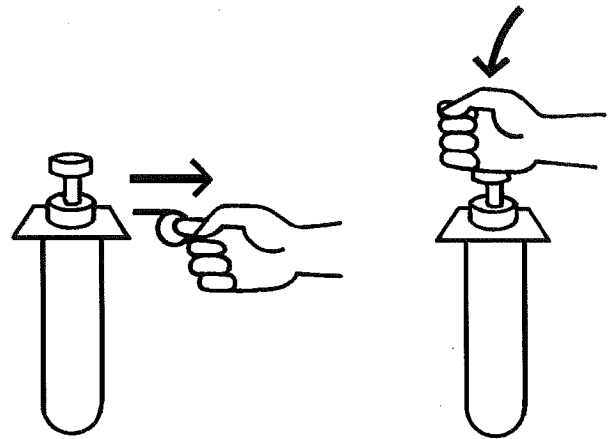

000627

4. Evacuate the vehicle

5. Stand by with a fire extinguisher

Inspection and Maintenance Record

| Date | Authorized ANSUL Distributor | Recharge | Inspection | Action Taken |
|------|------------------------------|----------|------------|--------------|
| | | | | |
| | | | | |
| | | | | |
| | | | | |
| | | | | |
| | | | | |
| | | | | |
| | | | | |
| | | | | |
| | | | | |
| | | | | |
| | | | | |

Your Authorized ANSUL Distributor